

UNIT	ED CIRCUIT CC	
MODEL #	LRWB 5-7M12	SCALE NTS



DWG. #	WV051214-DRD-ST	REV.	-
SERIAL #		DATE	11/2/2024

NOTES:

1. (M)- FAN MOTOR LOCATION
2. MPT DENOTES MALE PIPE THREAD  
FPT DENOTES FEMALE PIPE THREAD  
BFW DENOTES BEVELED FOR WELDING  
GVD DENOTES GROOVED  
FLG DENOTES FLANGE  
PE DENOTES PLAIN END
3. +UNIT WEIGHT DOES NOT INCLUDE ACCESSORIES (SEE ACCESSORY DRAWINGS)
4. 3/4" [19mm] DIA. MOUNTING HOLES. REFER TO RECOMMENDED STEEL SUPPORT DRAWING
5. DIMENSIONS LISTED AS FOLLOWS: ENGLISH FT IN [METRIC] [mm]
6. \* - APPROXIMATE DIMENSIONS DO NOT USE FOR PRE-FABRICATION OF CONNECTING PIPING
7. MAKE-UP WATER PRESSURE  
20 psi [137 kPa] MIN, 50 psi [344 kPa] MAX

**FACE B**  
**PLAN VIEW**

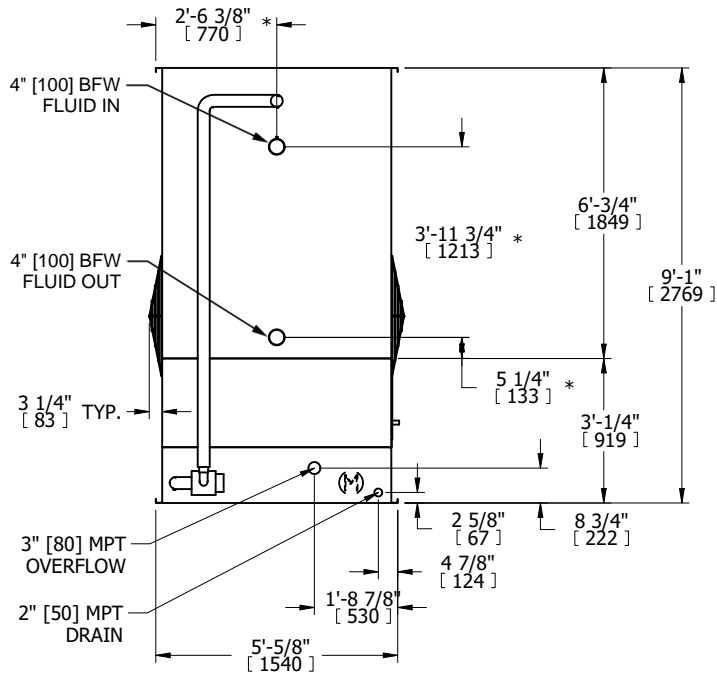
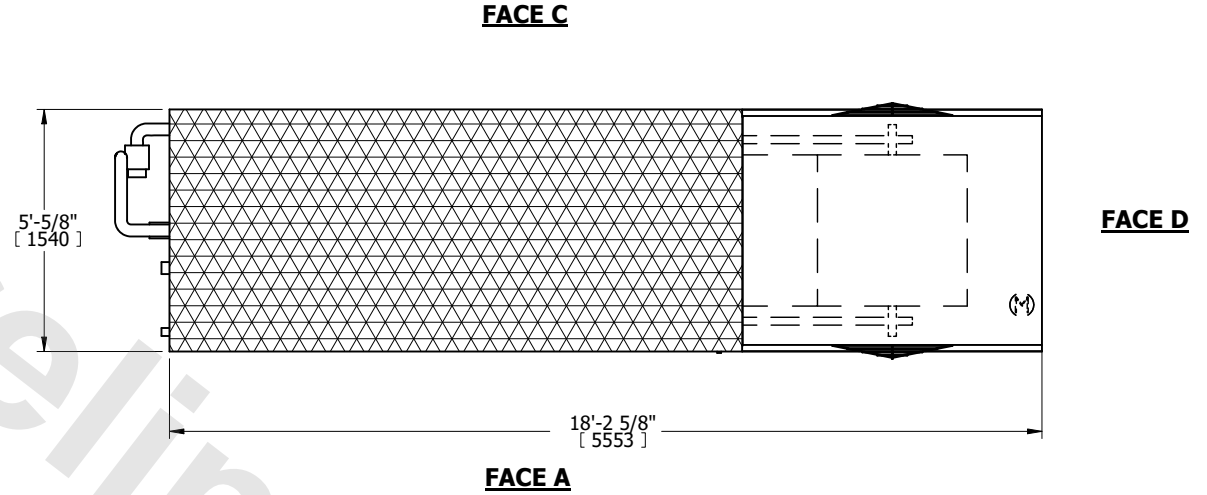

**FACE B**

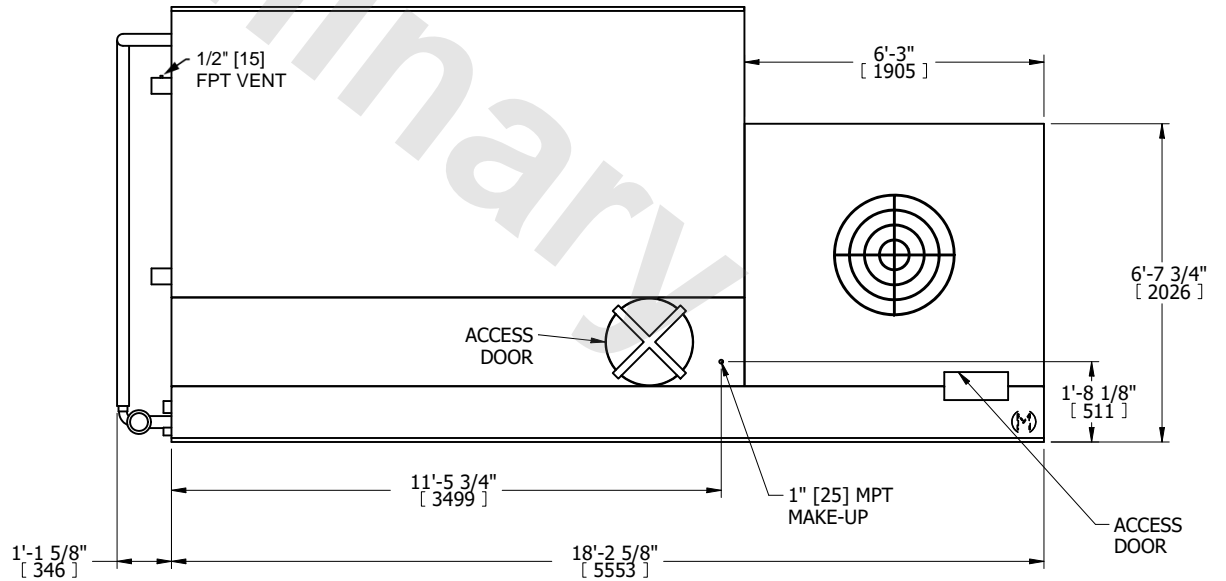

**FACE A**

SHIPPING WEIGHT	190 lbs+ [4625] †	OPERATING WEIGHT	‡80 lbs+ [7295] †	HEAVIEST SECTION WEIGHT	190 lbs+ [4625] †	NO. OF SHIPPING SECTIONS	1	DRAWN BY:	TLS
-----------------	-------------------	------------------	-------------------	-------------------------	-------------------	--------------------------	---	-----------	-----