

| | | |
|---------|----------------|-----------|
| UNIT | COOLING TOWER | |
| MODEL # | AT 248-4Q30-EV | SCALE NTS |

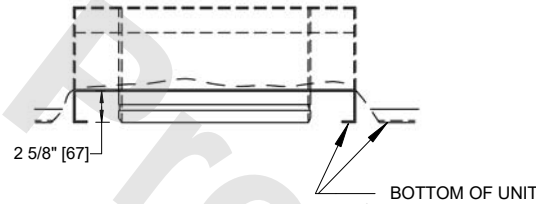

| | | | |
|----------|-----------------------|-------|-----------|
| DWG. # | ATL4BI48304E5T-DRC-DS | REV | - |
| SERIAL # | | DATE: | 11/1/2024 |

- NOTES
- (M)- FAN MOTOR LOCATION
 - HEAVIEST SECTION IS CASING SECTION
 - MPT DENOTES MALE PIPE THREAD
FPT DENOTES FEMALE PIPE THREAD
BFW DENOTES BEVELED FOR WELDING
GVD DENOTES GROOVED
FLG DENOTES FLANGE
 - +UNIT WEIGHT DOES NOT INCLUDE ACCESSORIES (SEE ACCESSORY DRAWINGS)
 - 3/4" [19mm] DIA. MOUNTING HOLES. REFER TO RECOMMENDED STEEL SUPPORT DRAWING
 - DIMENSIONS LISTED AS FOLLOWS
ENGLISH FT-IN
[METRIC] [mm]
 - FOR BOTTOM INLET SPECIFICATIONS, SEE DETAIL.



TYPICAL BOTTOM INLET CONNECTION DETAIL

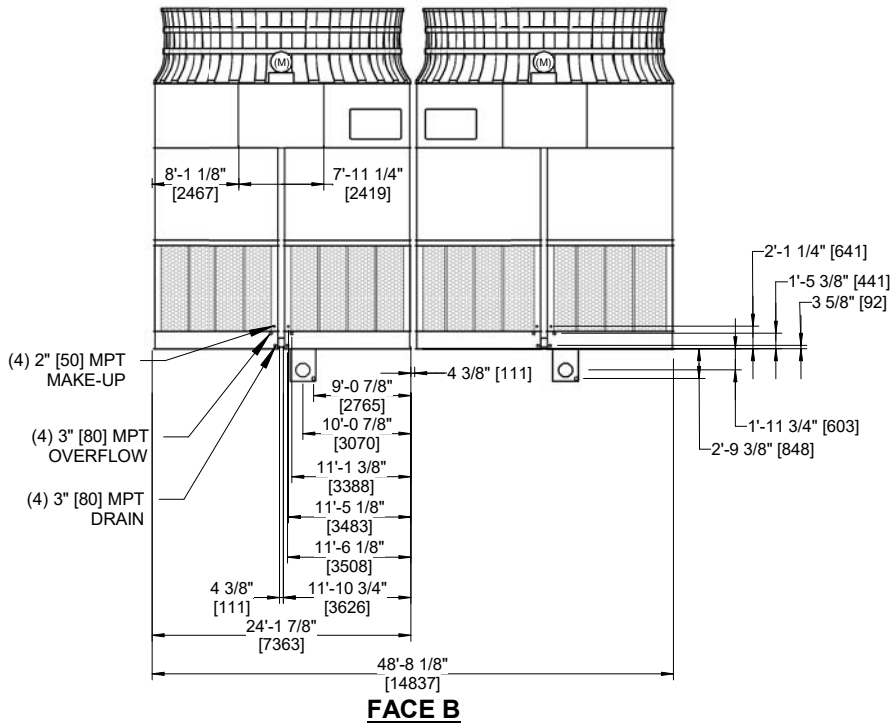
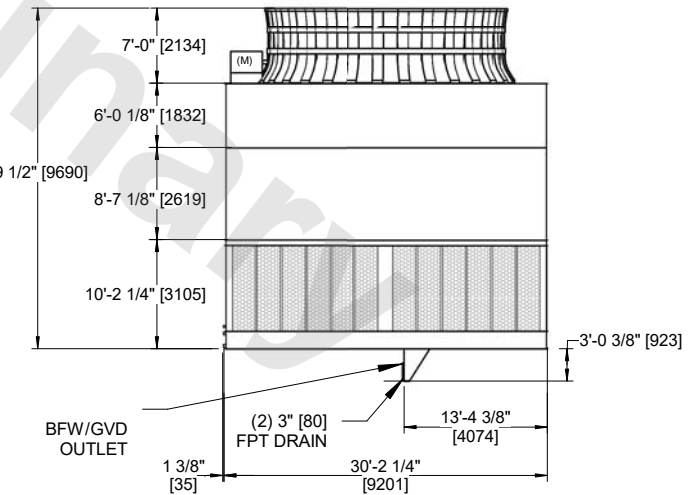
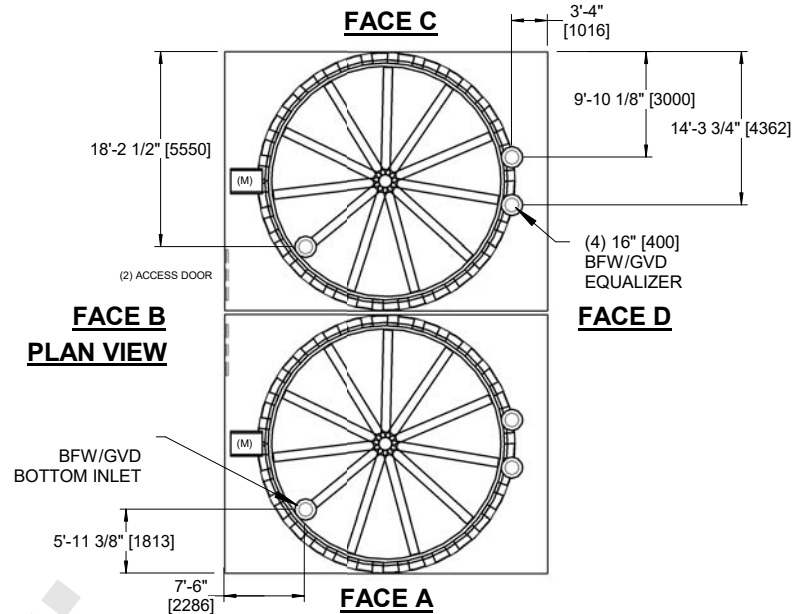

FACE B

FACE A

| | | | | | | | | | |
|-----------------|-------------------------|------------------|-------------------------|-------------------------|-----------------------|--------------------------|----|-----------|-----|
| SHIPPING WEIGHT | 135680 lbs+ [61545] kg+ | OPERATING WEIGHT | 188740 lbs+ [85615] kg+ | HEAVIEST SECTION WEIGHT | 12320 lbs+ [5590] kg+ | NO. OF SHIPPING SECTIONS | 14 | DRAWN BY: | JLG |
|-----------------|-------------------------|------------------|-------------------------|-------------------------|-----------------------|--------------------------|----|-----------|-----|