



for LIFE

# CLOSED CIRCUIT COOLERS



# ATWB Coolers



† Mark owned by the Cooling Technology Institute

# THE INDUSTRY'S SMARTEST INDUCED DRAFT Closed Circuit Cooler





## Get to Know EVAPCO

- The global innovator in heat transfer solutions
- Serving the commercial HVAC, Industrial Refrigeration, Power Generation, and Industrial Process markets
- Founded in 1976
- Employee-owned
- 33 locations in 14 countries
- More than 200+ sales offices worldwide

## Learn More Now

Visit [evapco.com](http://evapco.com) to download product catalogs, view complete product specifications, and more.

## EVAPCO is more than a name.

It is a pledge to make everyday life easier, more comfortable, more reliable, and more sustainable for people everywhere. How do we fulfill that promise? It is simple.

### **We never stop innovating.**

At EVAPCO, we do not just talk about innovation, It is ingrained in our workflow. Guided by our annually developed R&D plans, we set out to find groundbreaking solutions that transform the way the world works for the better. It is why we have more than 200 active patents worldwide.

### **We craft exceptionally built solutions.**

As an employee-owned company, we take pride in our work. We are proud to be one of the most experienced teams of engineers and craftsmen in the industry. This translates into solutions that are always exceptionally built. EVAPCO has an unwavering commitment to provide “best in class” heat transfer solutions and services.

### **We guarantee performance.**

Every EVAPCO solution is put through rigorous research and testing to ensure maximum efficiency and reliability. But we do not stop there. EVAPCO is an industry leader in independent, third-party performance certifications. These certifications guarantee our performance metrics—so that you can plan your projects with complete peace of mind.

### **We protect the environment.**

Innovation and environmental sustainability go hand-in-hand at EVAPCO. EVAPCO’s industrial heat transfer equipment not only conserves natural resources and helps reduce noise pollution, they also feature recycled steel content in their construction. Our stainless steel units are constructed of panels that contain up to 75% recycled content; over 80% in galvanized units construction. From sound reduction to water conservation to chemical elimination, we are constantly developing new technologies that deliver the ultimate operating advantages for our clients—and protect the planet for every generation that comes after us.



# Table of Contents

Corporate.....	2
Principle of Operation.....	4
Application Versatility.....	5
Design & Construction Features.....	6-7
Innovative Design Features.....	8-9
Power-Band Belt Drive System.....	10
Drive System Maintenance.....	11
Basin Design.....	12
Optional Equipment.....	13
Water Treatment Solutions.....	14-15
Low Sound Solutions.....	16
Electric Basin Heater.....	17
Coil Connection Options.....	18
Heat Exchanger Coil / Discharge Hood Dimensions.....	19
Heat Loss Data.....	20
General Information.....	21
Specifications.....	22
Engineering and Dimensions Data.....	23-70
Steel Support.....	71
Notes.....	72-73

# ATWB Principle of Operation

## Advanced Technology (AT) Closed Circuit Coolers

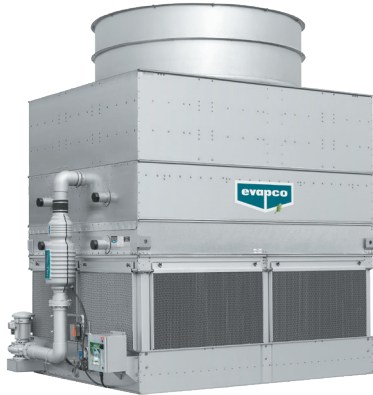

The ATWB line of closed circuit coolers has always reflected EVAPCO's commitment to product development. Its advanced design and owner-oriented features provide many operational and performance advantages. **The ATWB's Thermal-Pak® II Coil now features CROSSCOOL™ Internal Tube Enhancement which increases the internal heat transfer coefficient of the coil and thus increases the cooling capacity of the unit.** The improved ATWB offers the most models and box sizes in the industry and is designed with IBC Compliant Construction and CTI Certified Performance.

### Principle of Operation

The process fluid is circulated through the coil of the closed circuit cooler. Heat from the process fluid is dissipated through the coil tubes to the water cascading downward over the tubes. Simultaneously, air is drawn in through the air inlet louvers at the base of the cooler and travels upward over the coil opposite the water flow. A small portion of the water is evaporated, which removes the heat. The warm moist air is drawn to the top of the closed circuit cooler by the fan and is discharged to the atmosphere. The remaining water falls to the sump at the bottom of the cooler where it is recirculated by the pump up through the water distribution system and back down over the coils.

### Dry Operation

The ATWB closed circuit cooler is capable of higher dry bulb switchover temperatures than other bare-tube induced draft coolers due to a full footprint elliptical tube coil located entirely in the airstream. The number of coil rows and entering cold air combine to provide dry operation at times where the heat load and ambient conditions are favorable. The ability to satisfy the heat load without operating the spray pump provides both water and energy savings for a diversity of applications such as: commercial HVAC, data centers, industrial process, water source heat pumps, critical chilled water facilities, manufacturing plants, and many more.

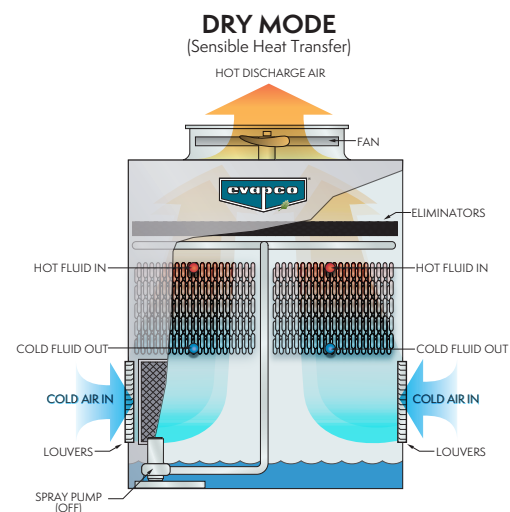
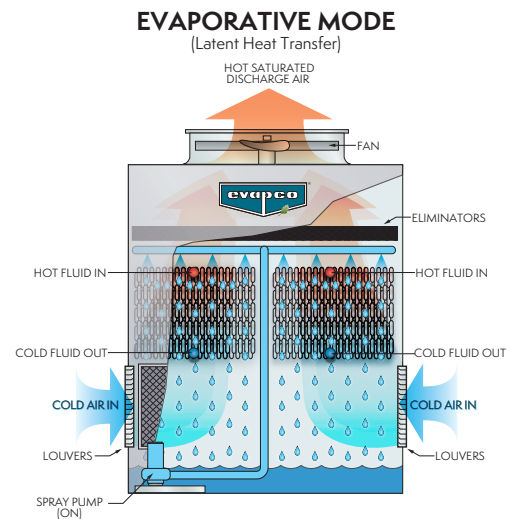



# Application Versatility

## Closing the Loop

Open cooling tower systems are susceptible to fouling on the heat transfer surfaces due to the process water being open to the environment, and pulling in dirt and debris from the surrounding area. Often, when used in conjunction with a plate and frame heat exchanger, there is the need to oversize the tower to make up for the efficiency lost across the heat exchanger. By closing the process fluid in the coils of a closed circuit cooler, both of these issues are eliminated.

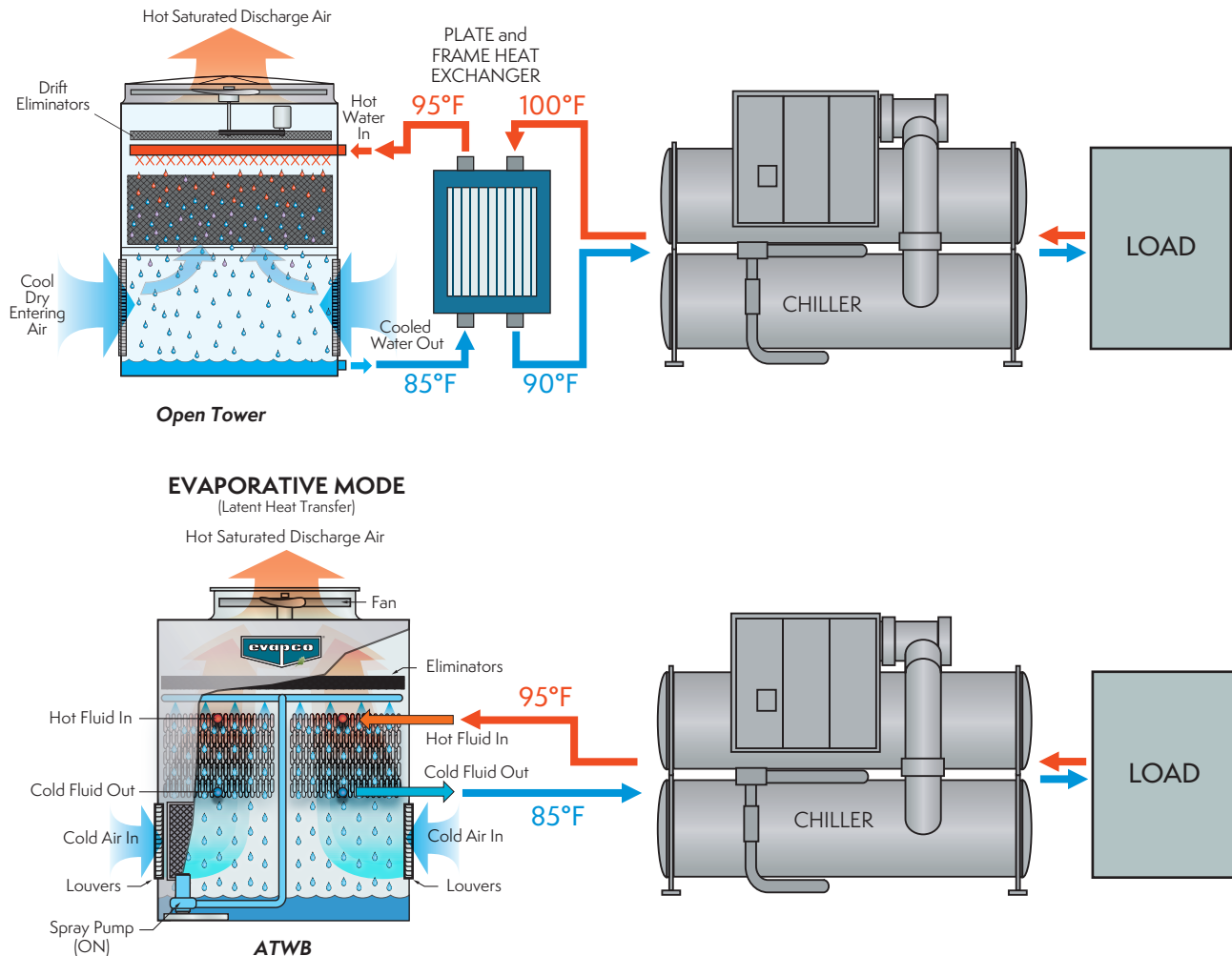

## High Temperature Applications

Many industrial applications have higher entering process fluid temperatures. A standard open cooling tower is limited by the fill at 130°F. The ATWB closed circuit cooler can operate with inlet process fluid temperatures up to 170°F. Galvanized steel, as well as type 304 and type 316 stainless steel materials can be used in the construction of the basin, casing and coil(s), providing years of reliable operation and corrosion resistance.

**NOTE:** Some high temperature applications require high temperature rated PVC materials. Please contact your local EVAPCO sales representative for high temperature applications.

# ATWB Design & Construction Feature



## Galvanized Steel Coil

### Elliptical Thermal-Pak® II Coil Construction Featuring **CROSSCOOL™** Internal Tube Enhancement Technology

- Internal tube enhancement increases fluid turbulence providing **additional evaporative capacity**
- Elliptical return bends allows for more circuits per coil bundle increasing maximum capacity per footprint
- Coil located in the airstream increasing dry bulb switchover



## Optional Factory Mounted Non-Chemical or Chemical Water Treatment Systems

The ATWB is available with either a **Pulse-Pure®** (pictured) non-chemical or a **Smart Shield®** (not shown) solid chemical water treatment system. The **Pulse-Pure®** and **Smart Shield®** are environmentally sensitive alternatives for treating water in evaporative cooled equipment. The **Pulse-Pure®** and **Smart Shield®** systems include all components required for an effective water treatment system; factory mounted and wired.



## Most Accessible Basin

- Access from all four sides
- Large open area simplifies maintenance
- Basin may be inspected with pumps running

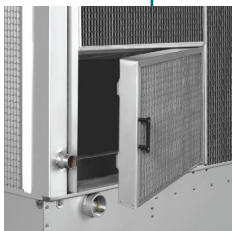

## Louver Access Door

- Louver access door is available on models with 5 and 6 ft. louver sizes
- Hinged access panel with quick-release mechanism
- Allows easy access to perform routine maintenance and inspection of the makeup assembly, strainer screen and basin

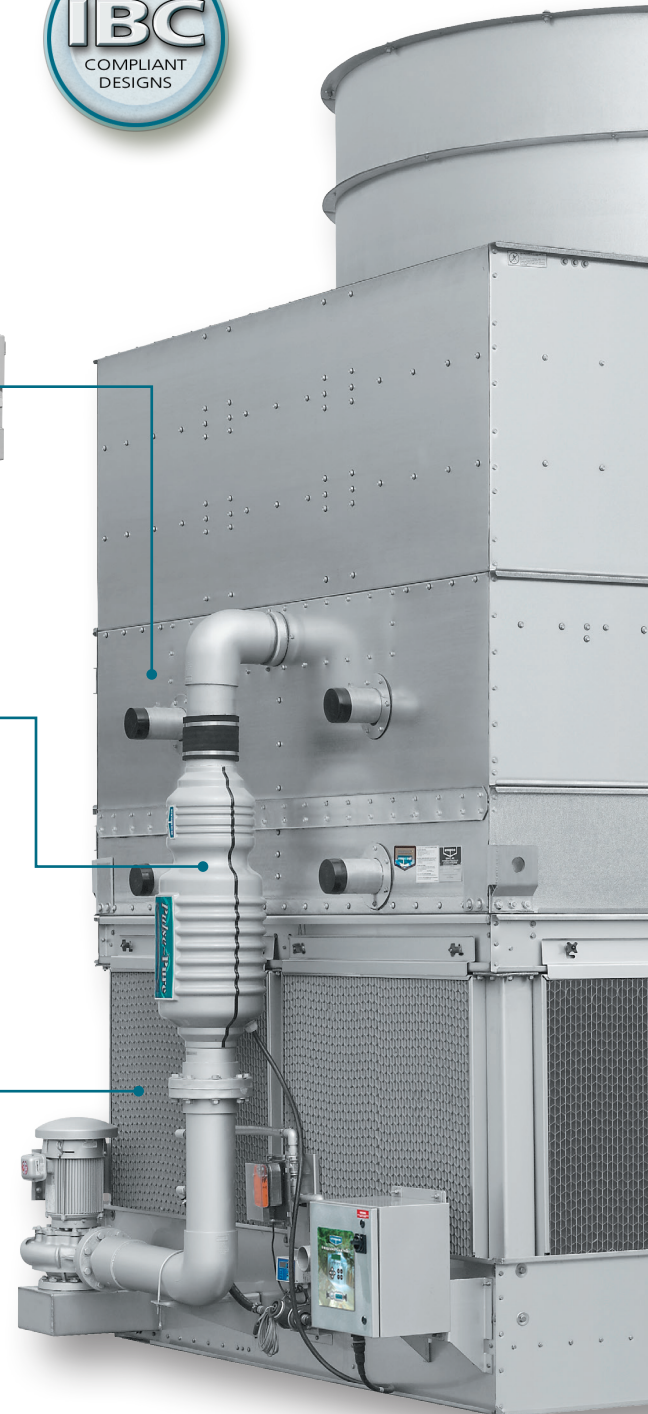



### Super Low Sound Fan

- Extremely wide sloped fan blades for sound-sensitive applications
- Molded heavy-duty construction
- 9-15 dB(A) sound reduction

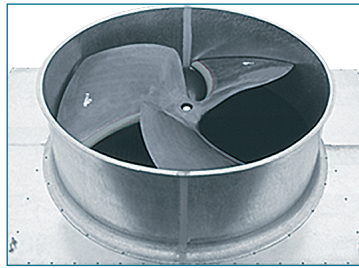

### Unique Fan Drive System

- Power-Band belts for better lateral rigidity
- Advanced design aluminum fan blades
- Non-corroding cast aluminum sheaves
- Heavy-duty fan shaft bearings with a minimum 100,000 hrs. L-10 life
- All other components constructed of corrosion-resistant materials
- Totally enclosed fan motors assure long life



### Efficient Drift Eliminators

- Advanced design minimizing drift from the leaving air stream
- Made from corrosion resistant PVC for long life



### PVC Spray Distribution Header with ZM™II Nozzles

- Large orifice fixed-position nozzles prevent clogging

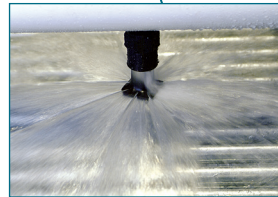

### The EVAPCO Performance Guarantee

Every ATWB product is rigorously thermal performance tested by EVAPCO and then independently certified by the Cooling Tower Institute (CTI) so you know you're getting a solution that's guaranteed to get the job done.

† Mark owned by the Cooling Technology Institute

### Water and Sight Tight (WST) Air Inlet Louvers

- Easily removable for access
- Improved design to keep sunlight out—preventing biological growth
- Keeps water in while keeping dirt and debris out



# Innovation Design Features

## Elliptical Thermal-Pak®II Heat Transfer Coil

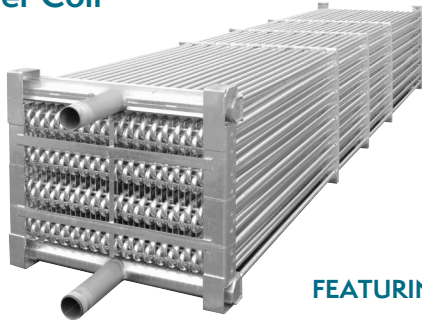

FEATURING

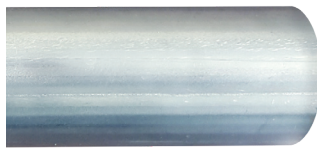

THERMAL-PAK® ELLIPTICAL TUBE

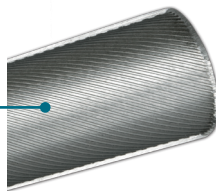

**CROSSCOOL™**  
INTERNAL TUBE ENHANCEMENT

## Galvanized steel elliptical Thermal-Pak®II Coil featuring **CROSSCOOL™** Internal Tube Enhancement Technology

- Internal tube enhancement provides additional evaporative capacity
- Elliptical tube design allows for more circuits per coil bundle increasing maximum capacity per footprint
- Elliptical tube design results in lower airflow resistance than typical round tube designs

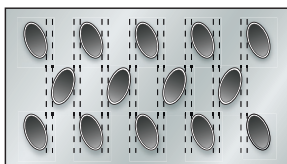

**EVAPCO's Thermal-Pak®II Elliptical Tube**

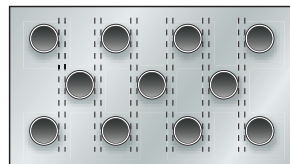

**Competitors' Round-Tube Coil**

The ATWB closed circuit coolers utilize EVAPCO's Thermal-Pak®II coil design. The elliptical tube design allows for closer tube spacing, resulting in greater surface area per plan area than round-tube coil designs.

In addition, the Thermal-Pak®II design has lower resistance to airflow and also permits greater water loading making the Thermal-Pak®II coil the most efficient design available.

The Thermal-Pak®II coil design also features EVAPCO's Internal Tube Enhancement Technology. This increases fluid turbulence through the coil, further increasing the evaporative capacity.

The coils are manufactured from high quality steel tubing following the most stringent quality control procedures. Each circuit is inspected to ensure the material quality and then tested before being assembled into a coil.

To protect the coil against corrosion, it is placed in a heavy steel frame and then the entire assembly is dipped into molten zinc (hot-dipped galvanized) at a temperature of approximately 800°F.

**NOTE:** Closed circuit coolers should only be used on sealed, pressurized systems. Continual aeration of the water in an open system can cause corrosion inside the tubes of the coil leading to premature failure.

## Stainless Steel Coil Option

EVAPCO offers the optional TITAN COIL. Constructed with type 304L stainless steel, the TITAN COIL is manufactured using EVAPCO's elliptical tube Thermal-Pak®II design upgraded to Xtra Tough construction featuring: Xtra Durability, Xtra Corrosion Resistance, and an Xtra long **5-Year Coil Warranty** as standard. Type 316 stainless steel coil is also available upon request.

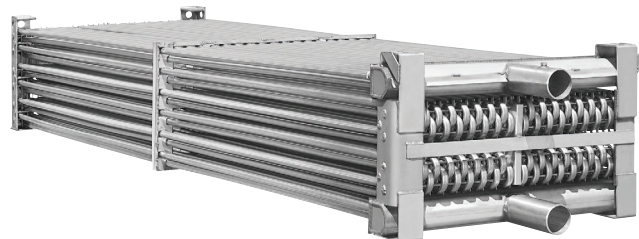

**Thermal-Pak®II Coil**



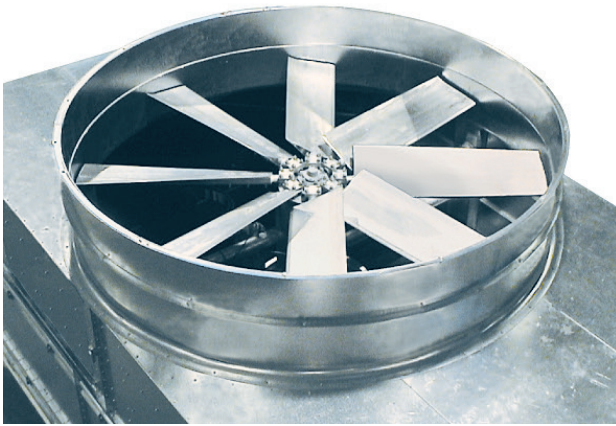

### Smooth Flow Fans

Smooth flow axial propeller fans come standard on all ATWB closed circuit coolers. Fan construction is dependent on unit size:

- 4-foot-wide: Fiberglass-reinforced polypropylene wide chord blades with die-cast aluminum hub
- Over 4 feet: 100% aluminum alloy fan blades

All fans are statically and dynamically balanced and installed in a closely fitted cowl with venturi air inlet for maximum efficiency. Fan screens are constructed of galvanized steel or optional type 304 stainless steel, and have steel frames bolted to the fan cowl.

Low sound and Super Low Sound Fan options are also available. See page 16 to learn more.

### Pressurized Water Distribution System

The ATWB closed circuit cooler's water distribution system is made of schedule 40 PVC pipe and ZM™II ABS plastic water nozzles for maximum corrosion protection. The piping is easily removable for cleaning. The water nozzles have a 1-5/16" diameter opening to help eliminate costly clogging.

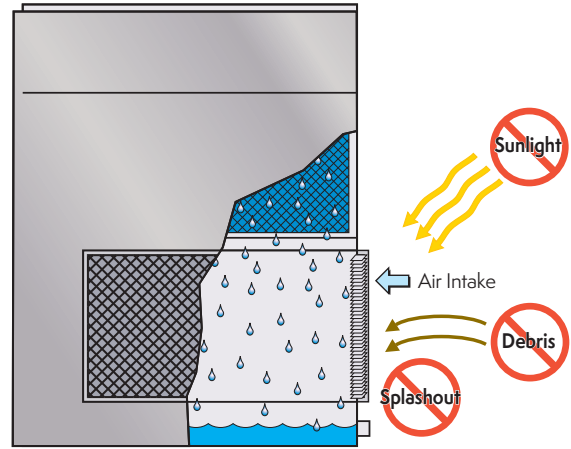

### Superior Air Inlet Louver Screen Design

EVAPCO's Water and Sight Tight (WST) inlet louver screens keep water in and sunlight out of your ATWB series closed circuit cooler. The unique, non-planar design is made from lightweight, framed PVC sections which have no loose hardware, enabling easy unit access. The louver's air channels are optimized to maintain fluid dynamic and thermodynamic efficiency and block all line-of-sight paths into the basin, eliminating splashout even when the fans are off. And because all sunlight is blocked, algae growth is minimized. The end result: reduced maintenance hours, water consumption, and water treatment costs.

### Maintenance Free ZM™II Spray Nozzle Water Distribution System

EVAPCO'S Zero Maintenance ZM™II spray nozzle remains clog-free while providing even and constant water distribution for reliable, scale-free evaporative cooling under all operating conditions.

The heavy duty nylon ZM™II spray nozzles have a 1-5/16" diameter opening. Furthermore, the fixed-position ZM™II nozzles are mounted in corrosion-free PVC water distribution pipes that have threaded end caps. Together, these elements combine to provide unequalled coil coverage and scale prevention, making it the industry's best performing non-corrosive, maintenance-free water distribution system.



ZM™II Nozzle

# The Power-Band Belt Drive System

## Power-Band Drive System Design

The ATWB closed circuit cooler features the highly successful Power-Band Belt Drive System. The Power-Band Drive System has performed consistently with trouble-free operation in the most severe conditions of closed circuit cooler applications. The reliability of the drive system is backed by a Five (5) Year complete drive system warranty.



Power-Band Belt

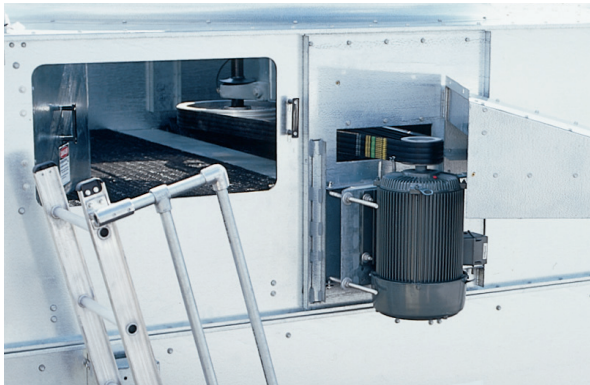

TEFC Fan Motor



TEAO Fan Motor

## Power-Band Drive System Includes:

- Solid back Power-Band drive belt
- Totally enclosed fan motors (TEFC or TEAO)
- Aluminum sheaves
- Fan shaft bearings with a minimum  $L_{10}$  life of 100,000 hrs.
- 5-year drive system warranty

## Power-Band Belt Drive

The Power-Band drive is a solid-backed multi-groove belt designed for closed circuit cooler service. The drive belt is sized for 150 percent of the motor nameplate horsepower and constructed of neoprene with polyester chords. Band belts are field-proven with over 20 years of field operation.

## Drive System Sheaves

Power-Band drive system sheaves are constructed of an aluminum alloy for corrosion resistance in the humid closed circuit cooler environment. Models with totally enclosed fan cooled (TEFC) motors have a steel driver sheave protected by a hinged cover.

## Fan Shaft Bearings

The fan shaft bearings are specially selected to provide long life, minimizing costly downtime. They are rated for a minimum  $L_{10}$  life of 100,000 hours, making them the heaviest duty pillow block bearings in the industry.

## Fan Motors

All EVAPCO closed circuit coolers utilize totally enclosed fan motors (TEFC or TEAO) designed specifically for evaporative cooling applications. Premium efficient fan motors which are compatible with variable frequency drive (VFD) systems, come standard on all ATWB models.

## Five Year Drive Warranty

EVAPCO provides a standard 5-year motor and drive warranty on all Power-Band drive systems. This warranty provides end users with complete protection against fan motor or drive component failure. The comprehensive warranty includes the fan, fan motor, fan shaft, belts, sheaves, and fan bearings.





# The Industry's Easiest Drive System Maintenance

## Standard Coolers (8.5 Feet Wide or Less)

The totally enclosed fan cooled (TEFC) motor is mounted on the outside and protected from the weather by a hinged cover that swings away for maintenance. A large, hinged access door is located on the side of the unit for easy access to the fan drive system. The belt can be adjusted by tightening the J-bolts on the motor base, and tension can be checked easily through the access door. The bearing lubrication lines have been extended to the exterior casing and are located by the access door, thus making bearing lubrication easy. Optional sloped maintenance ladders and working platforms are available to make maintenance even easier.



## Large Coolers (Over 8.5 Feet Wide)

The totally enclosed air over (TEAO) motor is located inside the fan casing and mounted on a unique, heavy-duty adjustable motor base that is designed to swing completely to the outside of the unit through a large, hinged access door (14 square feet/1.3 square meters). The belt can be easily adjusted from outside the unit via an all-thread that runs through the motor base, or via the motor base's unique locking mechanism if a wrench is not available. Bearing lubrication fittings are extended to the side of the unit inside the access door to allow for easy application of the bearing lubricant. To facilitate motor removal, an optional motor davit is available.

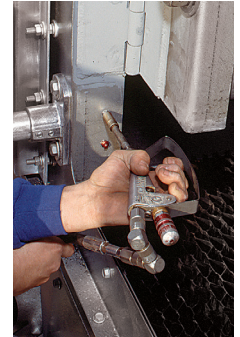

# Worry Free Maintenance Basin Design



## Easy Access

The cold water basin section is easily accessible from ground level by simply lifting out the lightweight louver. The basin can be accessed from all four sides of the closed circuit cooler, and the bottom of the fill section is a minimum of 4 feet (1.2 m) above the basin floor. This open design enables the basin to be easily cleaned.

**NOTE:** 4-foot-wide models are accessible on only two sides.

## Louver Access Door

To aid in basin maintenance, most ATWB models can be equipped with an optional louver access door. This allows easy access to perform routine maintenance and inspection of the makeup assembly, strainer screen, and basin without removing an entire inlet louver.

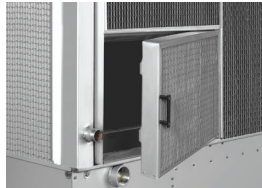

**NOTE:** This feature is standard on models with louvers 5 feet and taller and optional on models with 4-foot-tall louvers.

## Electric Water Level Control (Optional)

Closed circuit coolers may be ordered with an electric water level control in lieu of the standard mechanical float and makeup assembly. This package provides accurate control of water levels and does not require field adjustment.



## Stainless Steel Strainers

For most ATWB units, the strainer is subject to excessive wear and corrosion. All EVAPCO strainers are constructed with stainless steel—an enduring EVAPCO standard—ensuring that yours will last the life of your closed circuit cooler.

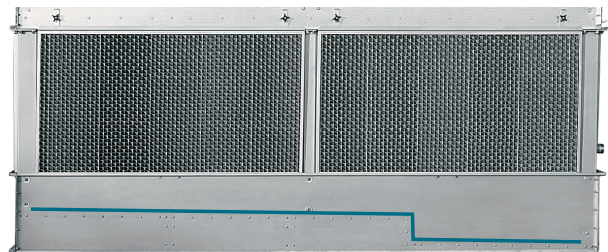

## Clean Pan Design

The ATWB series also features a completely sloped basin from the upper to lower pan section. This “clean pan” design allows the water to be completely drained from the basin. The closed circuit cooler spray water will drain from the upper section to the depressed lower pan section where the dirt and debris can be easily flushed out through the drain. This design helps prevent buildup of sedimentary deposits and biological films, and minimizes standing water.

**NOTE:** On 4-foot-wide units, the pan is sloped without the step.



# Optional Equipment

## Sloped Maintenance Ladders

Designed by EVAPCO and OSHA compliant, this sloped “ships type” ladder enables visual inspection of the water distribution system and drive components. What’s more, all standard drive system maintenance can be performed from the ladder. A handrail is attached to the sloped ladder for safe and easy ascent and descent—no need for safety cages.

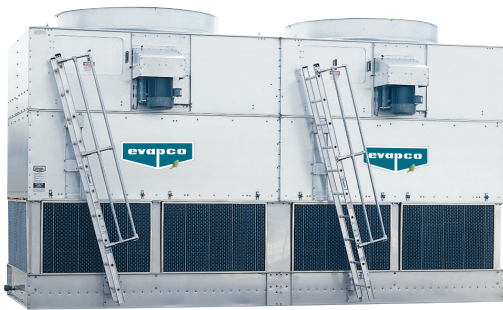

**NOTE:** Available on all models wider than 4 feet. A vertical ladder is available for smaller models. Ladder ships loose and must be field mounted.

## Working Platform & Ladder with Davit

Make it easy to service the fan motor and water distribution system with this heavy-duty, self-supporting working platform and standard ladder. A less expensive alternative to field erected catwalks, the system is OSHA compliant and ships in sections for easy installation.

**NOTE:** The working platform is not available on 4-foot-wide models.

Eliminate crane rentals with an optional davit that facilitates the easy removal of motors, gear drives, and fans. The davit is constructed of aluminum and is mounted on the side of the unit with a galvanized steel bracket.

**NOTE:** Davit ships loose and is installed in the field.



## Welded Stainless Steel Basin

The basin area of the fluid cooler often experiences dirt and debris buildup. Type 304 or 316 stainless steel is available to provide increased corrosion protection for the entire basin area including the support columns of the cooler and the air inlet louver frames.

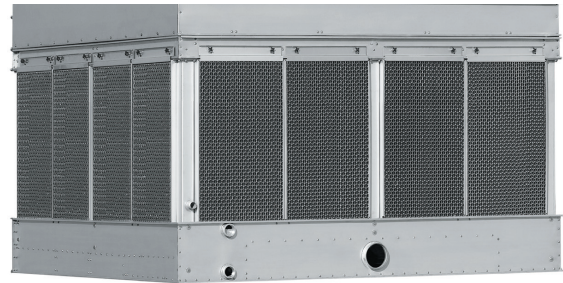

## All Stainless Steel Option (Excluding Fans/Coils)

In addition to the basin, the remainder of the unit is constructed of type 304 or 316 stainless steel. When this option is selected the unit panel construction contains either type 304 or 316 stainless steel. Fan cylinder and fan screen are also constructed of the same material.

## Basin Level Platform & Ladder

Available on select ATWB models that are elevated, the basin level platform and ladder facilitates easy basin inspections and maintenance, including float assembly adjustment and basin/suction strainer cleaning. The platform and ladder ship in modules for easy installation.

**NOTE:** Ladder requires field support.





## Our Industry-Leading Approach

To enhance passivation and minimize the formation of *white rust*, we've developed a two-step process that produces visible results. Even in applications requiring immediate heat load, we can provide practical solutions for galvanized steel equipment.

The EVAPCO Pass-Protect® process is a combination of:

Step 1: Passiv-Assist® Factory Applied Pretreatment

Step 2: Field Passivation

Experience a custom passivation plan that promotes the formation of a passive oxide layer, eliminating the need to feed white rust inhibitors for the life of the unit.



Learn more about this solution at [evapco.com](http://evapco.com).



## Engineered to Improve Water Efficiency

The EVAPCO Water Saver™ utilizes capacitive deionization technology to reduce dissolved ion concentration, thus lowering the makeup water conductivity prior to use in an evaporative cooling system. Makeup water entering the Water Saver passes through individual cylinders which contain oppositely charged supercapacitors. Dissolved ions (except silica) are removed from the water as they are absorbed onto the charged capacitors. A typical 50% ion reduction allows the operating cycles of concentration to be safely doubled without an increase in scale or corrosion potential.



View the Water Saver™ video and mechanical specifications at [evapco.com](http://evapco.com) to learn more.



Pretreatment System for Evaporative Cooling Equipment





### Pulse~Pure® Non-Chemical Water Treatment System



EVAPCO's *Pulse~Pure*® water treatment system utilizes pulsed electric field technology to provide an environmentally responsible alternative for the treatment of water in evaporative cooling equipment. The *Pulse~Pure*® system delivers short low- and high-frequency bursts of electromagnetic fields to the recirculating water in the fluid cooler.

- EVAPCO guarantees that total bacterial counts will not exceed 10,000 CFU/ml in the cooling water
- Controls scale, corrosion, and microbiological growth with absolutely no chemicals required
- Compact design with no moving parts and low energy consumption



Learn more about *Pulse~Pure*® at [evapco.com](http://evapco.com).



### Smart Shield® Solid Chemical Water Treatment System

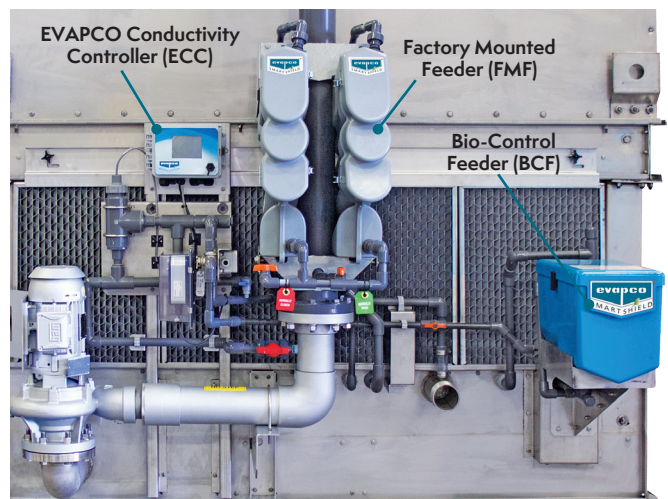

EVAPCO's *Smart Shield*® system utilizes proven solid chemistry delivered via our revolutionary feed system. With patented Controlled Release tablets, a scale and corrosion inhibitor is fed whenever your spray water pump is energized. Thus keeping your system protected anytime the spray water pump is operating.

*Smart Shield*® is a complete water treatment package that:

- Utilizes 'Bag in Bag' no touch chemical replenishments, making reloads easier and safer
- Creates reduced packaging, shipping and handling, providing a reduced carbon footprint compared to liquid chemicals
- Eliminates the hazards associated with liquid chemicals, potential for liquid spills, and the need for expensive feed pumps—making it the easiest and safest chemical water treatment system available today



Watch a short product video at [evapco.com](http://evapco.com).



# Optional Equipment: Low Sound Solutions

## Super Low Sound Fan – 9-15 dB(A) Reduction

When you are tasked with achieving the lowest sound levels possible, there is only one choice: the EVAPCO Super Low Sound Fan. It's the quietest, most noise efficient fan in the industry—capable of reducing sound pressure level by 9 to 15 dB(A)!

**NOTE:** Not available on 4-foot-wide models.



## Water Silencer – Reduces Water Noise up to 7 dB(A)

Located in the cold water basin, EVAPCO's water silencers reduce the high frequency noise associated with falling water and are capable of lowering overall sound levels 4 to 7 dB(A) when measured at 5 feet from the side or end of the unit. When water is circulated with fans off, the results are even greater: as much as 9 to 12 dB(A) lower at the same measured distance (depending on water loading and louver height). Constructed of lightweight PVC sections, the silencers can be easily removed for access to the basin area. It will have no impact on thermal performance and is CTI certified.

**NOTE:** Not available on 4-foot-wide models with Electronic Water Level Controller (EWLC) package.

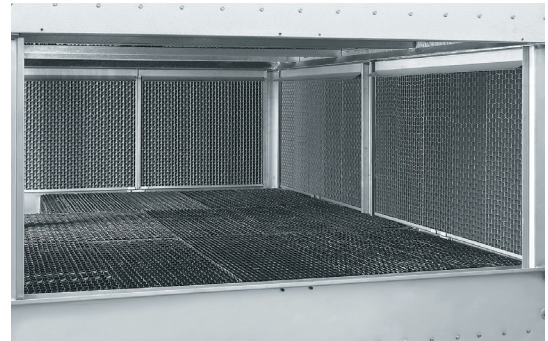

## Low Sound Fan – 4-7 dB(A) Reduction

Ideal for sound-sensitive applications, EVAPCO's low sound fan features a wide chord blade and a unique soft-connect blade-to-hub design that is compatible with variable speed drives. Since the blades are not rigidly connected to the fan hub, no vertical vibration forces are transmitted to the unit structure. This reduces sound pressure levels by 4 to 7 dB(A), depending on specific unit selection and measurement location.

The fan is a high-efficiency axial propeller and is CTI certified. The low sound fan has a thermal performance derate of 3.5%. Consult your local EVAPCO sales representative for actual thermal performance.

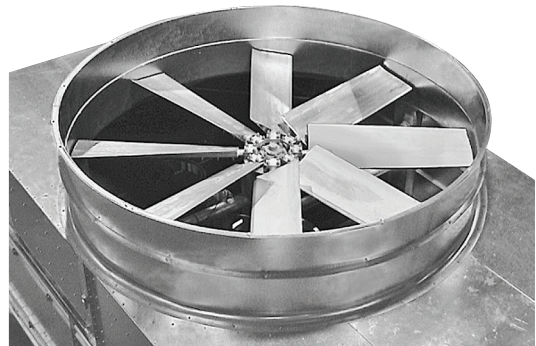

## Offset Sound Attenuation Walls

Add EVAPCO's CTI-certified offset sound attenuation walls to your Super Low Sound Fan and water silencer options for the ultimate sound control. Constructed of G-235 galvanized steel and lined inside with acoustical padding, the walls will typically reduce the 50-foot free-field sound level by an additional 3 dB(A). Stainless steel construction also available. Requires external support by others.

**NOTE:** Available only in combination with both Super Low Sound Fan and water silencer.



# Optional Equipment: Electric Basin Heaters

Electric immersion heaters can be added to the basin of your Advanced Technology series closed circuit cooler. They are sized to maintain a +40° F (4.5° C) pan water temperature with the fans and system pumps off. A thermostat and low-water protection device cycle the heater on when required and prevent the heater elements from energizing unless they are completely submerged. All components are protected by rugged, weatherproof enclosures for outdoor use.

**ATWB Heater Sizes \***

Unit No.	0°F kW	-20°F kW	-40°F kW
ATWB 4x6	(1) 3	(1) 4	(1) 5
ATWB 4x9	(1) 4	(1) 5	(1) 7
ATWB 4x12	(1) 5	(1) 7	(1) 9
ATWB 7x9	(1) 6	(1) 8	(2) 6
ATWB 7x12	(2) 4	(2) 6	(2) 8
ATWB 7x14	(2) 5	(2) 7	(2) 9
ATWB 7x18	(2) 6	(2) 8	(2) 12
ATWB 7x24	(4) 4	(4) 6	(4) 8
ATWB 7x28	(4) 5	(4) 7	(4) 9
ATWB 7x36	(4) 6	(4) 8	(4) 12
ATWB 14x9	(2) 6	(2) 8	(4) 6
ATWB 14x12	(4) 4	(4) 6	(4) 8
ATWB 14x14	(4) 5	(4) 7	(4) 9
ATWB 14x18	(4) 6	(4) 8	(4) 12
ATWB 2.4mx9	(1) 6	(1) 9	(1) 12
ATWB 2.4mx10.5	(1) 7	(1) 10	(1) 15
ATWB 2.4mx12	(2) 4	(2) 6	(2) 8
ATWB 2.4mx14	(2) 5	(2) 7	(2) 9
ATWB 2.4mx18	(2) 6	(2) 9	(2) 12
ATWB 2.4mx21	(2) 7	(2) 10	(2) 15
ATWB 2.4mx24	(4) 4	(4) 6	(4) 8
ATWB 2.4mx28	(4) 5	(4) 7	(4) 9
ATWB 2.4mx36	(4) 6	(4) 9	(4) 12
ATWB 2.4mx42	(4) 7	(4) 10	(4) 15
ATWB 4.8mx9	(2) 6	(2) 9	(2) 12
ATWB 4.8mx10.5	(2) 7	(2) 10	(2) 15
ATWB 4.8mx12	(4) 5	(4) 7	(4) 9
ATWB 4.8mx14	(4) 5	(4) 7	(4) 9
ATWB 8.5x7.5	(1) 6	(1) 7	(1) 9
ATWB 8.5x9	(1) 7	(1) 10	(1) 15
ATWB 8.5x10.5	(1) 8	(1) 12	(1) 15
ATWB 8.5x12	(2) 4	(2) 7	(2) 9
ATWB 8.5x14	(2) 5	(2) 7	(2) 10
ATWB 8.5x18	(2) 6	(2) 9	(2) 12
ATWB 8.5x21	(2) 7	(2) 12	(2) 15
ATWB 8.5x24	(4) 4	(4) 7	(4) 9
ATWB 8.5x28	(4) 5	(4) 7	(4) 10
ATWB 17x12	(4) 4	(4) 7	(4) 9
ATWB 17x14	(4) 5	(4) 7	(4) 10
ATWB 3mx12	(2) 5	(2) 8	(2) 10
ATWB 3mx18	(2) 7	(2) 12	(2) 15
ATWB 3mx24	(4) 5	(4) 8	(4) 10
ATWB 3mx36	(4) 7	(4) 12	(4) 15
ATWB 3mx36	(6) 5	(6) 8	(6) 10
ATWB 3mx54	(6) 7	(6) 12	(6) 15
ATWB 6mx12	(4) 5	(4) 8	(4) 10
ATWB 6mx18	(4) 7	(4) 12	(4) 15
ATWB 6mx24	(4) 10	(4) 15	(4) 20
ATWB 6mx36	(4) 15	(6) 15	(6) 20

**ATWB Heater Sizes \***

Unit No.	0°F kW	-20°F kW	-40°F kW
ATWB 12x12	(2) 6	(2) 9	(2) 12
ATWB 12x14	(2) 7	(2) 10	(2) 15
ATWB 12x18	(2) 9	(2) 15	(2) 18
ATWB 12x20	(2) 10	(2) 15	(3) 15
ATWB 12x24	(4) 6	(4) 9	(4) 12
ATWB 12x28	(4) 7	(4) 10	(4) 15
ATWB 12x36	(4) 9	(4) 15	(4) 18
ATWB 12x40	(4) 10	(4) 15	(6) 15
ATWB 24x12	(4) 6	(4) 9	(4) 12
ATWB 24x14	(4) 7	(4) 10	(4) 15
ATWB 24x18	(4) 9	(4) 15	(4) 18
ATWB 24x20	(4) 10	(4) 15	(4) 20
ATWB 24x24	(4) 12	(4) 18	(6) 15
ATWB 24x28	(4) 15	(4) 20	(6) 18
ATWB 24x36	(4) 18	(6) 18	(8) 18
ATWB 24x40	(4) 20	(6) 20	(8) 20

\* Electric heater selection based on ambient air temperature shown.

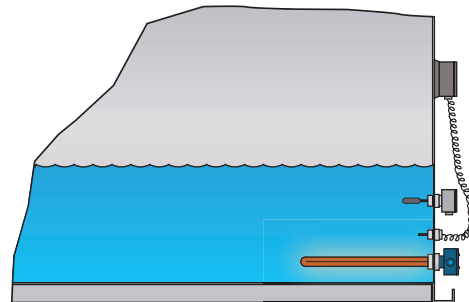

**NOTE:** Heater control packages that include contactor, transformer, or disconnects are also available; speak to your local EVAPCO sales representative to learn more about these options.

# Coil Connection Options

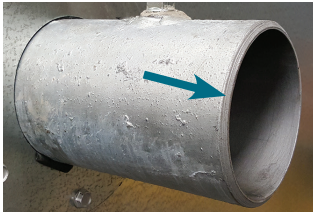

## Beveled For Weld (BFW) Coil Connections

EVAPCO Closed Circuit Coolers are provided with Beveled For Weld (BFW) coil connections as standard. Beveled edges simplify field welding and allow welds to fully penetrate.



## Optional Factory Mounted Crossover Piping

Some EVAPCO Closed Circuit Coolers are design for "series flow" coil operation where the coils inside of one cell are operated in series. These units are denoted by a "-Z" following the unit model number. These units require "crossover piping" from one coil to the other. As an option, this piping can be installed in the factory for simplified field installation.



## Optional Grooved Coil Connections

Grooved connections can be provided as an optional coil connection. The groove allows for a mechanical coupling allowing for faster and easier field piping.

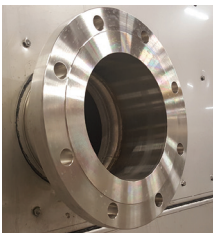

## Optional Flanged Coil Connections

150# Raised Faced Flanged connections can be provided as an optional coil connection. The flanged coil connection allows for faster and easier field piping to a mating flanged connection. 300# flanged can be provided in some cases. Please see your local sales representative.

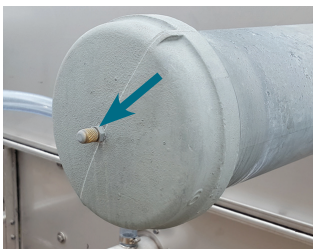

## Optional Nitrogen Charged Coils

For projects requiring long term storage or ocean freight, coils can be nitrogen charged at the factory to prevent corrosion inside of the coil circuits.



## Optional Male Pipe Thread (MPT) Coil Connections

Male Pipe Thread connections can be provided as an optional connection for mating with Female Pipe Thread (FPT) piping.

**NOTE:** All coil connections are constructed from the same material as the coil.



# Heat Exchanger Coil / Discharge Hood Dimensions

## Heat Exchanger Coil

The simplest and most foolproof method of protecting the heat exchanger coil from freeze-up is to use a glycol solution. If this is not possible, an auxiliary heat load must be maintained on the coil at all times so that the water temperature does not drop below 50°F when the cooler is shut down. Also, a minimum recommended flow rate per unit must be maintained. Refer to Heat Loss Data Table on page 20 for heat loss data.

Minimum Flows	Standard Flow GPM	Series Flow GPM
<b>4' Wide Models</b>		
ATWB 4x6 to 4x12	–	37
<b>7' Wide Models</b>		
ATWB 7x9 to 7x18	140	70
ATWB 7x24 to 7x36	280	140
<b>8-1/2' Wide Models</b>		
ATWB 9x8 to 9x21	160	80
<b>10' Wide Models</b>		
ATWB 10x12 to 10x18	188	94
ATWB 10x24 to 10x36	376	188
<b>12' Wide Models</b>		
ATWB 12x12 to 12x20	232	116
ATWB 12x24 to 12x40	464	232
<b>14' Wide Models</b>		
ATWB 14x9 to 14x18	280	140
<b>17' Wide Models</b>		
ATWB 17x12 to 17x14	320	160
<b>20' Wide Models</b>		
ATWB 20x12 to 20x18	376	188
ATWB 20x24 to 20x36	752	376
<b>24' Wide Models</b>		
ATWB 24x12 to 24x20	464	232
ATWB 24x24 to 24x40	928	464

## Discharge Hoods with Positive Closure Dampers

When a closed circuit cooler is used in a water-to-air heat pump system or in certain process cooling applications, a method of reducing the heat loss during idle periods of wintertime operation may be required. For these cases, an optional discharge hood with positive closure dampers and damper actuator is available.

The discharge hood with dampers is designed to minimize the heat loss from convective airflow through an idle cooler. Further reductions in heat loss may be obtained with the addition of insulation to the hood and casing, minimizing conductive heat losses. Insulation may be factory installed on the hood and casing or field installed by an insulation contractor.

The discharge hood and dampers are constructed of hot-dip galvanized steel. Hoods are equipped with access panels to facilitate maintenance of the eliminators and water distribution system. The dampers, damper actuator and linkage are all factory assembled. Actuator controls and wiring are field supplied by others. Damper actuators require 120 volt power supply.

The system control sequence should allow for dampers to be fully open before the fans are running and closed when the fans are off; the damper actuator must be interlocked with the

temperature control system for this purpose.

Heat loss data is provided for standard units without hoods, with hoods and with hoods and insulation. Table ratings are based on 50°F water in the coil, -10°F ambient and 45 MPH winds (fan and pump off). Refer to page 20.

## Discharge Hood Dimensions

Model	L	H*	W	Weight	Number of Hoods
ATWB 4x6	5' 11-7/8"	1' 6"	4' 1/4"	360	1
ATWB 4x9	8' 11-1/2"	1' 6"	4' 1/4"	510	1
ATWB 4x12	11' 11-3/4"	1' 6"	4' 1/4"	660	1
ATWB 9x8	7' 5-7/8"	1' 4"	8' 5-1/2"	850	1
ATWB 9x9	8' 11-3/8"	1' 4"	8' 5-1/2"	980	1
ATWB 9x11 ATWB 9x12 ATWB 9x14	10' 5-1/2"	1' 4"	8' 5-1/2"	1,140	1
ATWB 9x18	8' 11-1/2"	1' 4"	8' 5-1/2"	1,960	2
ATWB 9x21	10' 5-1/2"	1' 4"	8' 5-1/2"	2,280	2
ATWB 17x12 ATWB 17x14	10' 5-1/2"	1' 4"	8' 5-1/2"	2,120	2
ATWB 10x12 ATWB 10x18	11' 11-5/8"	1' 2"	10' 2-1/4"	1,730	1
ATWB 10x24 ATWB 10x36 ATWB 20x12 ATWB 20x18	11' 11-5/8"	1' 2"	10' 2-1/4"	3,460	2
ATWB 20x24 ATWB 20x36	11' 11-5/8"	1' 2"	10' 2-1/4"	6,920	4
ATWB 12x12 ATWB 12x14 ATWB 12x18 ATWB 12x20	11' 11-3/4"	1' 2"	11' 10"	1,800	1
ATWB 12x24 ATWB 12x28 ATWB 12x36 ATWB 12x40	11' 11-3/4"	1' 2"	11' 10"	3,600	2
ATWB 24x12 ATWB 24x14 ATWB 24x18 ATWB 24x20	11' 11-3/4"	1' 2"	11' 10"	3,600	2
ATWB 24x24 ATWB 24x28 ATWB 24x36 ATWB 24x40	11' 11-3/4"	1' 2"	11' 10"	7,200	4

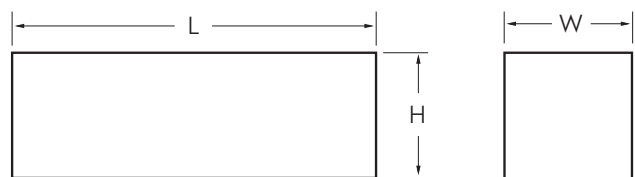

# Heat Loss Data, MBH

ATWB Model	Standard Unit	Unit w/Hood	Hood and Insulation	ATWB Model	Standard Unit	Unit w/Hood	Hood and Insulation	ATWB Model	Standard Unit	Unit w/Hood	Hood and Insulation	ATWB Model	Standard Unit	Unit w/Hood	Hood and Insulation
3-2x3	16	16	10	9-3x11	259	134	86	12-3x20	723	292	187	20-3x18	1052	375	240
3-3x3	23	19	12	9-4x11	313	143	91	12-4x20	875	309	198	20-4x18	1274	395	253
3-4x3	27	21	13	9-5x11	352	152	97	12-5x20	982	326	209	20-5x18	1431	416	266
3-5x3	31	23	15	9-6x11	374	161	103	12-6x20	1046	343	220	20-6x18	1524	436	279
4-2x4	32	30	19	9-7x11	381	168	107	12-7x20	1065	343	220	20-7x18	1551	436	279
4-3x4	44	37	24	9-3x12	296	147	94	12-3x24	860	335	215	20-3x24	1393	458	293
4-4x4	53	40	26	9-4x12	359	156	100	12-4x24	1041	354	227	20-4x24	1687	482	308
4-5x4	60	43	28	9-5x12	403	166	106	12-5x24	1169	374	239	20-5x24	1895	505	324
4-3x6	67	54	35	9-6x12	429	176	112	12-6x24	1245	393	252	20-6x24	2017	529	339
4-4x6	81	59	38	9-7x12	437	183	117	12-7x24	1267	393	252	20-7x24	2054	529	339
4-5x6	91	64	41	9-3x14	347	163	105	12-3x28	1006	378	242	20-3x36	2105	624	400
4-3x9	102	73	46	9-4x14	420	174	112	12-4x28	1218	400	256	20-4x36	2548	654	419
4-4x9	124	79	50	9-5x14	472	185	118	12-5x28	1368	421	270	20-5x36	2862	684	438
4-5x9	139	85	54	9-6x14	502	195	125	12-6x28	1456	443	284	20-6x36	3047	714	457
4-3x12	137	91	58	9-7x14	511	204	130	12-7x28	1483	443	284	20-7x36	3103	714	457
4-4x12	166	98	63	9-3x18	448	197	126	12-3x36	1299	465	298	24-3x12	860	335	215
4-5x12	186	106	68	9-4x18	542	210	134	12-4x36	1572	491	314	24-4x12	1041	354	227
7-3x9	193	-	-	9-5x18	609	222	143	12-5x36	1766	516	331	24-5x12	1169	374	239
7-4x9	234	-	-	9-6x18	648	235	151	12-6x36	1880	542	347	24-6x12	1245	393	252
7-5x9	263	-	-	9-7x18	660	245	157	12-7x36	1914	542	347	24-7x12	1267	393	252
7-6x9	280	-	-	9-3x21	524	223	143	12-3x40	1445	508	326	24-3x14	1006	366	234
7-7x9	285	-	-	9-4x21	634	237	152	12-4x40	1749	536	343	24-4x14	1218	386	247
7-3x12	259	-	-	9-5x21	712	251	161	12-5x40	1965	564	361	24-5x14	1368	407	260
7-4x12	314	-	-	9-6x21	758	265	170	12-6x40	2092	592	379	24-6x14	1456	427	273
7-5x12	353	-	-	9-7x21	772	275	176	12-7x40	2130	592	379	24-7x14	1483	427	273
7-6x12	376	-	-	10-3x12	348	184	118	14-3x9	386	-	-	24-3x18	1299	427	274
7-7x12	382	-	-	10-4x12	422	195	125	14-4x9	468	-	-	24-4x18	1572	450	288
7-3x14	304	-	-	10-5x12	474	207	133	14-5x9	525	-	-	24-5x18	1766	472	303
7-4x14	367	-	-	10-6x12	504	219	140	14-6x9	559	-	-	24-6x18	1880	495	317
7-5x14	413	-	-	10-7x12	513	219	140	14-7x9	570	-	-	24-7x18	1914	495	317
7-6x14	439	-	-	10-3x18	526	244	156	14-3x12	519	-	-	24-3x20	1445	458	293
7-7x14	447	-	-	10-4x18	637	259	166	14-4x12	628	-	-	24-4x20	1749	482	308
7-3x18	392	-	-	10-5x18	716	274	176	14-5x12	705	-	-	24-5x20	1965	505	324
7-4x18	474	-	-	10-6x18	762	289	185	14-6x12	751	-	-	24-6x20	2092	529	339
7-5x18	533	-	-	10-7x18	776	289	185	14-7x12	765	-	-	24-7x20	2130	529	339
7-6x18	567	-	-	10-3x24	697	304	195	14-3x14	607	-	-	24-3x24	1719	519	333
7-7x18	578	-	-	10-4x24	843	323	207	14-4x14	735	-	-	24-4x24	2081	545	349
7-3x24	519	-	-	10-5x24	947	341	218	14-5x14	826	-	-	24-5x24	2338	571	366
7-4x24	628	-	-	10-6x24	1009	359	230	14-6x14	879	-	-	24-6x24	2489	597	382
7-5x24	705	-	-	10-7x24	1027	359	230	14-7x14	895	-	-	24-7x24	2535	597	382
7-6x24	751	-	-	10-3x36	1052	425	272	14-3x18	784	-	-	24-3x28	2012	581	372
7-7x24	765	-	-	10-4x36	1274	450	288	14-4x18	949	-	-	24-4x28	2436	609	390
7-3x28	607	-	-	10-5x36	1431	474	304	14-5x18	1066	-	-	24-5x28	2736	637	408
7-4x28	735	-	-	10-6x36	1524	499	320	14-6x18	1135	-	-	24-6x28	2913	664	426
7-5x28	826	-	-	10-7x36	1551	499	320	14-7x18	1155	-	-	24-7x28	2966	664	426
7-6x28	879	-	-	12-3x12	430	205	131	17-3x12	593	230	147	24-3x36	2597	704	451
7-7x28	895	-	-	12-4x12	520	218	140	17-4x12	718	244	156	24-4x36	3144	736	471
7-3x36	784	-	-	12-5x12	585	231	148	17-5x12	806	257	165	24-5x36	3532	768	492
7-4x36	949	-	-	12-6x12	622	244	156	17-6x12	858	271	174	24-6x36	3760	800	513
7-5x36	1066	-	-	12-7x12	634	244	156	17-7x12	874	282	180	24-7x36	3829	800	513
7-6x36	1135	-	-	12-3x14	503	227	145	17-3x14	694	253	162	24-3x40	2890	765	490
7-7x36	1155	-	-	12-4x14	609	241	154	17-4x14	840	268	172	24-4x40	3499	799	512
9-3x8	181	104	67	12-5x14	684	255	163	17-5x14	943	283	181	24-5x40	3930	834	534
9-4x8	219	111	71	12-6x14	728	269	172	17-6x14	1004	297	190	24-6x40	4184	868	556
9-5x8	246	119	76	12-7x14	728	269	172	17-7x14	1023	308	198	24-7x40	4260	868	556
9-6x8	262	127	81	12-3x18	649	270	173	20-3x12	697	292	187				
9-7x8	267	132	85	12-4x18	786	286	183	20-4x12	843	309	198				
9-3x9	221	121	78	12-5x18	883	302	194	20-5x12	947	326	209				
9-4x9	267	129	83	12-6x18	940	318	204	20-6x12	1009	343	220				
9-5x9	300	138	88	12-7x18	957	318	204	20-7x12	1027	343	220				
9-6x9	320	146	93												
9-7x9	325	152	98												

# Specifications

## SECTION 23 65 00 – FACTORY-FABRICATED COOLING TOWERS

### PART 1 – GENERAL

- 1.1 RELATED DOCUMENTS
- A. Drawings and general provisions of the Contract, including General and Supplementary Conditions and Division 1 Specification Sections, apply to this section.
- 1.2 SUMMARY:
- A. This Section includes factory assembled and tested, closed circuit, induced draft counterflow cooling tower (also known as a closed circuit cooler).
- 1.3 SUBMITTALS
- A. General. Submit the following:
1. Certified drawings of the closed circuit cooler, sound data, recommended steel support indicating weight loadings, wiring diagrams, installation instructions, operation and maintenance instructions, and thermal performance guarantee by the manufacturer.
- 1.4 QUALITY ASSURANCE
- A. Verification of Performance:
1. Test and certify closed circuit cooler thermal performance according to CTI Standard 201.
  2. Test and certify closed circuit cooler sound performance according to CTI ATC-128.
- B. Meet or Exceed energy efficiency per ASHRAE 90.1.
- 1.5 WARRANTY
- A. Motor/Drive System: Five (5) year comprehensive warranty against materials and workmanship including motor, fan, bearings, mechanical support, sheaves, bushings and belt.
- B. Unit: One (1) year from start-up, not to exceed eighteen (18) months from shipment on the unit.

### PART 2 - PRODUCTS

- 2.1 MANUFACTURERS
- A. Manufacturers: Subject to compliance with requirements, provide closed circuit coolers manufactured by one of the following:
1. EVAPCO, Inc.
  2. Approved Substitute
- 2.2 MATERIALS
- A. Galvanized Sheet Steel complying with ASTM A 653/A 653M and having G-235 designation.
- B. Optional Type 304 and/or 316 Stainless Steel as specified.
- 2.3 INDUCED-DRAFT, COUNTERFLOW CLOSED CIRCUIT COOLERS
- A. Description: Factory assembled and tested, induced draft counterflow closed circuit cooler complete with coil, fan, louvers, accessories, and rigging supports.
- B. Closed Circuit Cooler Characteristics and Capacities: Refer to the closed circuit cooler schedule.
- C. Fan(s):
1. Type and Material: Axial propeller, individually adjustable wide chord blade extruded aluminum installed in a closely fitted cowl with venturi air inlet for maximum efficiency, covered with a heavy gauge hot dipped Galvanized Steel fan guard.
  2. Maximum sound pressure level of \_\_\_\_\_dB(A) measured at 5 feet above the fan discharge during full speed operation in accordance with CTI Standard ATC-128.
- D. Water Distribution System: Non-corrosive materials.
1. Evenly distribute of water over fill material with pressurized spray tree.
    - a. Pipes: Schedule 40 PVC, Non-corrosive Materials
    - b. Nozzles: Non-clogging, nylon, threaded into branch piping.
  2. Maximum pressure at inlet shall be \_\_\_\_\_ psig.
- E. IBC Compliance: The unit structure shall be designed, analyzed, and constructed in accordance with the latest edition of the International Building Code (IBC) Regulations for seismic loads up to \_\_\_\_\_ g and wind loads up to \_\_ psf.
- F. Collection Basin Material: Galvanized Steel. Type 304 or 316 Stainless Steel Optional:
1. Removable stainless-steel strainer with openings smaller than nozzle orifices.

2. Joints: Bolted and sealed watertight or welded.
  3. Overflow, makeup and side drain connections
  4. Flume plate between cells (for multiple-cell units) or Equalizer connection (for multiple- closed circuit cooler system).
- G. Heat Transfer Coil: Heavy Gauge G-235 Galvanized Steel encased in a steel framework, assembly hot-dip galvanized after construction. Type 304 or 316 Stainless Steel Optional. Coil assembly completely enclosed and protected from sunlight exposure, environmental elements and debris. Tubes sloped for free drainage of the coil and designed for low pressure drop. The coil shall have design pressure of 300 psi and shall be in compliance with ANSI/ASME B31.5, Refrigeration Piping and Heat Transfer Components. The coil assembly shall be strength tested in accordance with ANSI/ASME B31.5 and subsequently leak tested using air under water. Coil connections beveled for weld, flanged (optional) or grooved (optional).
- H. Casing: Galvanized Steel. Type 304 or 316 Stainless Steel Optional:
1. Casing panels shall totally encase the heat transfer coil.
  2. Fasteners: Corrosion resistance equal to or better than materials being fastened.
  3. Joints: Sealed watertight.
  4. Welded Connections: Continuous and watertight
- I. Drift Eliminators: PVC, for long life and durability resistant to rot, decay and biological attack; formed, bonded together for strength and durability in block format for easy removal and replacement; self extinguishing with flame spread rating of 5 per ASTM E84-81a; 0.001% drift rate.
- J. Air Inlet Louvers: Formed PVC; designed "Sight Tight" to completely block direct sunlight from entering and water from splashing out of the closed circuit cooler.
- K. Water Level Control: Brass mechanical makeup water valve and plastic float with an adjustable linkage.
- L. Water Recirculation Pump: Close-coupled, centrifugal type with mechanical seal. The pump motor shall be \_\_\_\_\_ horsepower totally enclosed for outdoor service on \_\_\_\_\_ volts, \_\_\_\_\_ hertz, and \_\_\_\_\_ phase.
- 2.4 MOTORS AND DRIVES
- A. General requirements for motors are specified in Division 15 Section "Motors".
- B. Enclosure Type: TEAO or TEFC
- C. Motor Speed: Premium Efficient VFD Duty (Option: 2-speed)
- D. Drive: Power-Band Belt designed for 150% of the motor nameplate HP.
1. Belt: Multi-groove, solid back V-belt type neoprene reinforced with polyester cord.
  2. Sheaves: Aluminum alloy if located inside the airstream.
  3. Bearings: Heavy duty, self-aligning pillow block bearings with lubrication lines extended to side access door. Minimum L10 life for bearings shall be 100,000 hours. Provide extended grease lines and fittings.
  4. Vibration Cutout Switch: (optional) Mechanical switch to de-energize fan motors if excessive vibration in NEMA 4 enclosure.
- 2.5 MAINTENANCE ACCESS
- A. Internal Working / Service Platforms: Provide a complete internal working platform and ladder system for service of all drive components. A suitable working platform may be constructed of the heat transfer coil for counterflow closed circuit coolers. If a crossflow cooler is used, provide an internal walkway with ladder and elevated working platform to allow for service and maintenance to motor and drive assembly.
- B. Handrails/Grabrails: Galvanized steel pipe complying with 29 CFR 1910.23. If access to fan deck is required, supply a perimeter handrail with ladder from grade to fan deck.
- C. Ladders: (optional) Aluminum, sloped "ships type" with grabrail or vertical complying with 29 CFR 1910.27.



# General Information

## Design

EVAPCO closed circuit coolers are of heavy-duty construction and designed for long trouble-free operation. Proper equipment selection, installation and maintenance is, however, necessary to ensure full unit performance. Some of the major considerations in the application of a cooler are presented below. For additional information, contact the factory.

## Air Circulation

It is important that proper air circulation be provided. The best location is on an unobstructed roof top or on ground level away from walls and other barriers. Those closed circuit coolers located in wells, enclosures or adjacent to high walls must be properly located to avoid the problems associated with recirculation.

Recirculation raises the wet bulb temperature of the entering air causing the water temperature to rise above the design. For these cases, the discharge of the unit should be located at a height even with or higher than the adjacent wall, thereby reducing the chance of recirculation. For additional information, see the EVAPCO equipment layout manual.

Good engineering practice dictates that the closed circuit cooler discharge air not be directed or located close to or in the vicinity of building air intakes.

## Piping

Cooler piping should be designed and installed in accordance with generally accepted engineering practices. The piping layout should be symmetrical on multiple unit systems, and sized for a reasonably low water velocity and pressure drop.

The standard closed circuit cooler is recommended only on a closed, pressurized system. The piping system should include an expansion tank to allow for fluid expansion and purging air from the system.

**NOTE:** *Closed circuit coolers should never be used on an open type system. An open type system with a cooler may result in premature coil failure.*

The piping system should be designed to permit complete drainage of the heat exchanger coil. This will require a vacuum breaker or air vent to be installed at the high point and a drain valve installed at the low point of the piping system. Both must be adequately sized.

All piping should be securely anchored by properly designed hangers and supports. No external loads should be placed upon the cooler connections, nor should any of the pipe supports be anchored to the cooler framework.

## Recirculating Water Quality

Proper water treatment is an essential part of the maintenance required for evaporative cooling equipment. A well designed and consistently implemented water treatment program will help to ensure efficient system operation while maximizing the equipment's service life. **If EVAPCO factory mounted water systems are not utilized**, a qualified water treatment company should design a site-specific water treatment protocol based on equipment (including all metallurgies in the cooling system), location, makeup water quality, and usage.

## Bleed Off

Evaporative cooling equipment requires a bleed or blowdown line, located on the discharge side of the recirculating pump, to remove concentrated (cycled up) water from the system. EVAPCO recommends an automated conductivity controller to maximize the water efficiency of your system. **If EVAPCO factory mounted water systems are not utilized**, based on recommendations from your water treatment company, the conductivity controller should open and close a motorized ball or solenoid valve to maintain the conductivity of the recirculating water. If a manual valve is used to control the rate of bleed it should be set to maintain the conductivity of the recirculating water during periods of peak load at the maximum level recommended by your water treatment company.

## Water Treatment

The water treatment program prescribed for the given conditions must be compatible with the unit's materials of construction, including any galvanized components. The initial commissioning and passivation period is a critical time for maximizing the service life of galvanized equipment. EVAPCO recommends that the site-specific water treatment protocol includes a passivation procedure which details water chemistry, any necessary chemical addition, and visual inspections during the first six (6) to twelve (12) weeks of operation. During this passivation period, recirculating water pH should be maintained above 7.0 and below 8.0 at all times. Batch feeding of chemicals is not recommended.

## Control of Biological Contaminants

Evaporative cooling equipment should be inspected regularly to ensure good microbiological control. Inspections should include both monitoring of microbial populations via culturing techniques and visual inspections for evidence of biofouling.

Poor microbiological control can result in loss of heat transfer efficiency, increased corrosion potential, and an increased risk of pathogens such as those that cause Legionnaires' disease. Your site-specific water treatment protocol should include procedures for routine operation, startup after a shutdown period, and system lay-up, if applicable. If excessive microbiological contamination is detected, a more aggressive mechanical cleaning and/or water treatment program should be undertaken.

# ATWB 3-2C3-Z to ATWB 3-5D3-Z

Selections for ATWB Closed Circuit Coolers are available from EVAPCO's **SPECTRUM™** Program. Please contact your local sales representative for more information on the **SPECTRUM™** program.

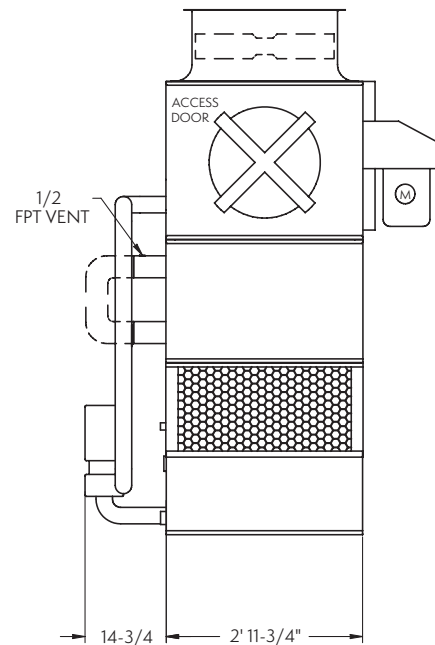
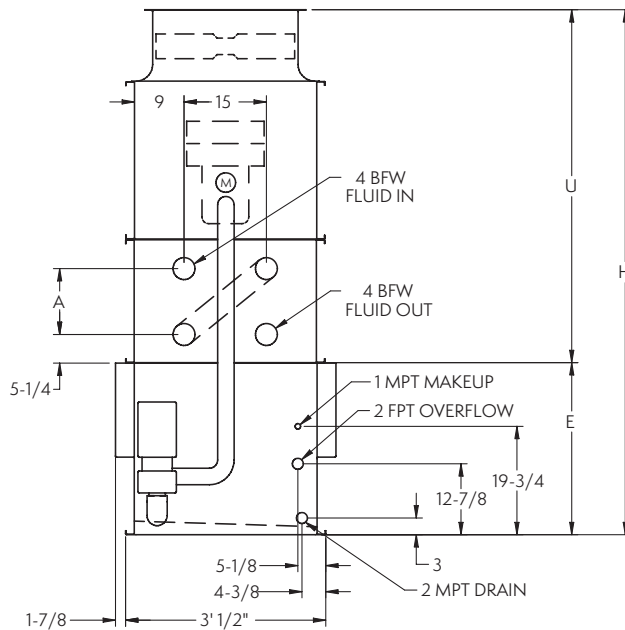
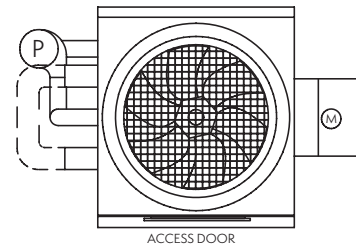

NOTE: The number of coil connections doubles when the flow rate exceeds 450 GPM on 3x3 models. This required option is referred to as the High Flow coil configuration.

ATWB Model Number†	Weights (lbs)			Fans		Spray Pump		Coil Volume (Gallons)	Remote Sump <sup>△</sup>			Dimensions <sup>■</sup>			
	Shipping	Heaviest Section††	Operating	HP	CFM	HP	GPM		Gallons <sup>*</sup> Required	Conn. Size	Operating Weight (lbs)	Coil A	Upper U	Lower E	Height H
ATWB 3-2C3-Z	1,150	870	1,680	1	4,600	3/4	50	16	45	6"	1,440	12"	5' 4-1/4"	2' 7-3/8"	7' 11-5/8"
ATWB 3-3C3-Z	1,310	1,030	1,890	1	4,470	3/4	50	21	45	6"	1,650	20-1/2"	6' 3/4"	2' 7-3/8"	8' 8-1/8"
ATWB 3-4C3-Z	1,450	1,170	2,070	1	4,340	3/4	50	26	45	6"	1,830	29"	6' 9-1/4"	2' 7-3/8"	9' 4-5/8"
ATWB 3-4D3-Z	1,460	1,180	2,080	1.5	4,910	3/4	50	26	45	6"	1,840	29"	6' 9-1/4"	2' 7-3/8"	9' 4-5/8"
ATWB 3-5C3-Z	1,600	1,320	2,260	1	4,210	3/4	50	31	45	6"	2,020	37-1/2"	7' 5-3/4"	2' 7-3/8"	10' 1-1/8"
ATWB 3-5D3-Z	1,610	1,330	2,270	1.5	4,760	3/4	50	31	45	6"	2,030	37-1/2"	7' 5-3/4"	2' 7-3/8"	10' 1-1/8"

† Model Numbers end in "-Z" for units with Series Flow piping configuration. 3x3 ATWB units are only available in Series Flow and will require crossover piping which can either be supplied by the factory or by others. Model numbers will include "C" for units with Stainless Steel coil(s), "R" for units with Low Sound Fan(s) and "S" for units with an option that negates CTI certification.

†† Heaviest section is the coil/fan section.

\* Gallons shown is water in suspension in unit and piping. Allow for additional water in bottom of remote sump to cover pump suction and strainer during operation (12" would normally be sufficient).

△ When a remote sump arrangement is selected, the spray pump, suction strainer and associated piping are omitted; the unit is provided with an oversized outlet to facilitate drainage to the remote sump.

■ Unit dimensions and coil connections may vary slightly from catalog. See factory certified prints for dimensions, quantity of coil connections, and piping configuration. Coil connections are 4" bevel for weld (BFW). Other connection types such as grooved for mechanical coupling or flanged are also available as options.



# ATWB 4-2E4 to 4-5F4

Selections for ATWB Closed Circuit Coolers are available from EVAPCO's **SPECTRUM™** Program. Please contact your local sales representative for more information on the **SPECTRUM™** program.

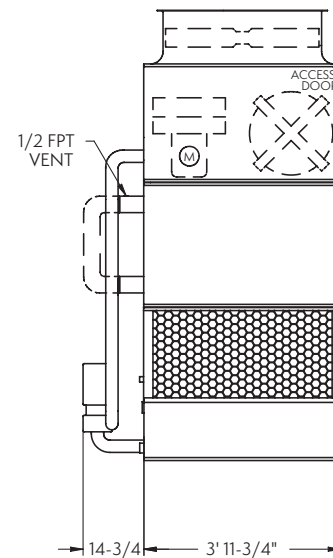
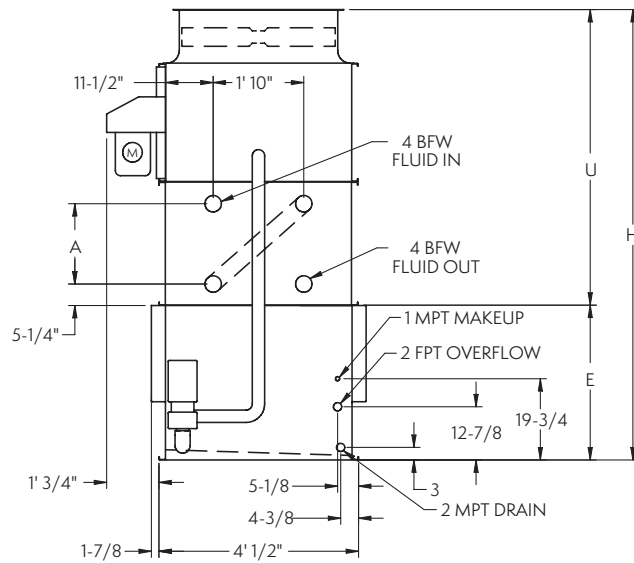
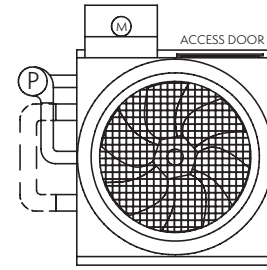

**NOTE:** The number of coil connections doubles when the flow rate exceeds 450 GPM on 4x4 models. This required option is referred to as the High Flow coil configuration.

ATWB Model Number†	Weights (lbs)			Fans		Spray Pump		Coil Volume (Gallons)	Remote Sump <sup>△</sup>			Dimensions <sup>■</sup>			
	Shipping	Heaviest Section††	Operating	HP	CFM	HP	GPM		Gallons* Required	Conn. Size	Operating Weight (lbs)	Coil A	Upper U	Lower E	Height H
ATWB 4-2E4-Z	1,710	1,320	2,660	2	8,650	3/4	90	26	80	6"	2,310	12"	5' 4-1/8"	3' 1-5/8"	8' 5-3/4"
ATWB 4-3E4-Z	2,000	1,610	3,030	2	8,400	3/4	90	36	80	6"	2,680	19-1/2"	5' 11-5/8"	3' 1-5/8"	9' 1-1/4"
ATWB 4-4E4-Z	2,250	1,860	3,360	2	8,160	3/4	90	46	80	6"	3,010	27"	6' 7-1/8"	3' 1-5/8"	9' 8-3/4"
ATWB 4-4F4-Z	2,280	1,890	3,390	3	9,190	3/4	90	46	80	6"	3,040	27"	6' 7-1/8"	3' 1-5/8"	9' 8-3/4"
ATWB 4-5E4-Z	2,520	2,130	3,710	2	7,910	3/4	90	56	80	6"	3,360	34-1/2"	7' 2-5/8"	3' 1-5/8"	10' 4-1/4"
ATWB 4-5F4-Z	2,550	2,160	3,740	3	8,910	3/4	90	56	80	6"	3,390	34-1/2"	7' 2-5/8"	3' 1-5/8"	10' 4-1/4"

† Model Numbers end in "-Z" for units with Series Flow piping configuration. 4x4 ATWB units are only available in Series Flow and will require crossover piping which can either be supplied by the factory or by others. Model numbers will include "C" for units with Stainless Steel coil(s), "R" for units with Low Sound Fan(s) and "S" for units with an option that negates CTI certification.

†† Heaviest section is the coil/fan section.

\* Gallons shown is water in suspension in unit and piping. Allow for additional water in bottom of remote sump to cover pump suction and strainer during operation (12" would normally be sufficient).

<sup>△</sup> When a remote sump arrangement is selected, the spray pump, suction strainer and associated piping are omitted; the unit is provided with an oversized outlet to facilitate drainage to the remote sump.

<sup>■</sup> Unit dimensions and coil connections may vary slightly from catalog. See factory certified prints for dimensions, quantity of coil connections, and piping configuration. Coil connections are 4" bevel for weld (BFW). Other connection types such as grooved for mechanical coupling or flanged are also available as options.

# ATWB 4-3E6 to 4-5G6

Selections for ATWB Closed Circuit Coolers are available from EVAPCO's **SPECTRUM™** Program. Please contact your local sales representative for more information on the **SPECTRUM™** program.

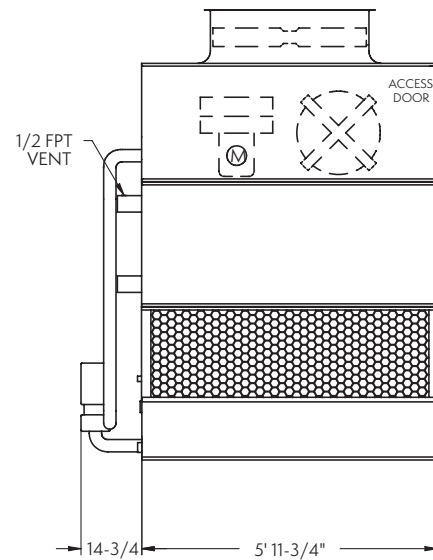
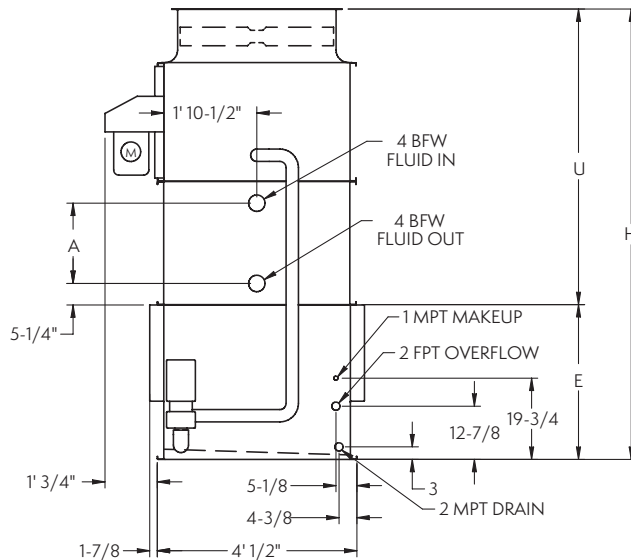
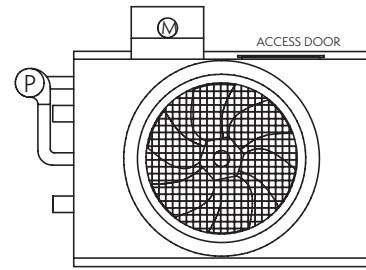

NOTE: The number of coil connections doubles when the flow rate exceeds 450 GPM on 4x6 models. This required option is referred to as the High Flow coil configuration.

ATWB Model Number†	Weights (lbs)			Fans		Spray Pump		Coil Volume (Gallons)	Remote Sump <sup>△</sup>			Dimensions ■			
	Shipping	Heaviest Section††	Operating	HP	CFM	HP	GPM		Gallons*	Conn. Size	Operating Weight (lbs)	Coil A	Upper U	Lower E	Height H
ATWB 4-3E6	2,750	2,240	4,270	2	10,990	3/4	135	52	120	6"	3,810	19-1/2"	5' 11-5/8"	3' 1-5/8"	9' 1-1/4"
ATWB 4-3F6	2,780	2,270	4,300	3	12,580	3/4	135	52	120	6"	3,840	19-1/2"	5' 11-5/8"	3' 1-5/8"	9' 1-1/4"
ATWB 4-3G6	2,790	2,280	4,310	5	14,590	3/4	135	52	120	6"	3,850	19-1/2"	5' 11-5/8"	3' 1-5/8"	9' 1-1/4"
ATWB 4-4E6	3,120	2,610	4,770	2	10,670	3/4	135	67	120	6"	4,310	27"	6' 7-1/8"	3' 1-5/8"	9' 8-3/4"
ATWB 4-4F6	3,150	2,640	4,800	3	12,210	3/4	135	67	120	6"	4,340	27"	6' 7-1/8"	3' 1-5/8"	9' 8-3/4"
ATWB 4-4G6	3,160	2,650	4,810	5	14,160	3/4	135	67	120	6"	4,350	27"	6' 7-1/8"	3' 1-5/8"	9' 8-3/4"
ATWB 4-5E6	3,530	3,020	5,300	2	10,350	3/4	135	83	120	6"	4,840	34-1/2"	7' 2-5/8"	3' 1-5/8"	10' 4-1/4"
ATWB 4-5F6	3,560	3,050	5,330	3	11,840	3/4	135	83	120	6"	4,870	34-1/2"	7' 2-5/8"	3' 1-5/8"	10' 4-1/4"
ATWB 4-5G6	3,570	3,060	5,340	5	13,740	3/4	135	83	120	6"	4,880	34-1/2"	7' 2-5/8"	3' 1-5/8"	10' 4-1/4"

† Model Numbers end in "-Z" for units with Series Flow piping configuration. Series Flow units may require additional coil connections and will require crossover piping. Model numbers will include "C" for units with Stainless Steel coil(s), "R" for units with Low Sound Fan(s) and "S" for units with an option that negates CTI certification.

†† Heaviest section is the coil/fan section.

\* Gallons shown is water in suspension in unit and piping. Allow for additional water in bottom of remote sump to cover pump suction and strainer during operation (12" would normally be sufficient).

△ When a remote sump arrangement is selected, the spray pump, suction strainer and associated piping are omitted; the unit is provided with an oversized outlet to facilitate drainage to the remote sump.

■ Unit dimensions and coil connections may vary slightly from catalog. See factory certified prints for dimensions, quantity of coil connections, and piping configuration. Coil connections are 4" bevel for weld (BFW). Other connection types such as grooved for mechanical coupling or flanged are also available as options.

# ATWB 4-3E9 to 4-5F9 ATWB 4-3E12 to 4-5G12

Selections for ATWB Closed Circuit Coolers are available from EVAPCO's **SPECTRUM™** Program. Please contact your local sales representative for more information on the **SPECTRUM™** program.

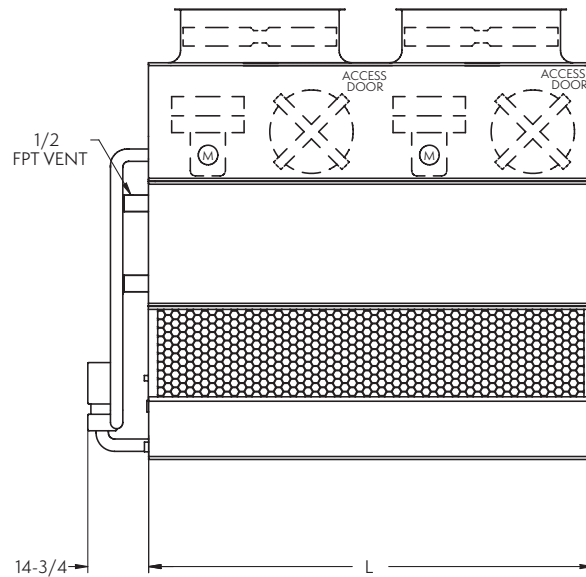
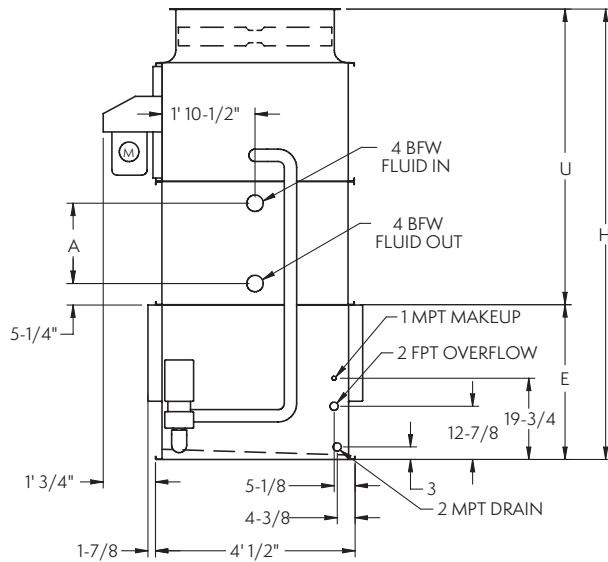
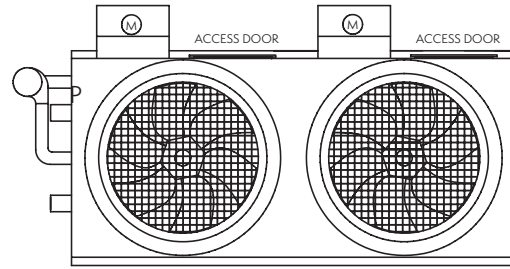

NOTE: The number of coil connections doubles when the flow rate exceeds 450 GPM on ATWB 4x9 and 4x12 models. This required option is referred to as the High Flow coil configuration.

ATWB Model Number†	Weights (lbs)			Fans		Spray Pump		Coil Volume (Gallons)	Remote Sump△			Dimensions ■				
	Shipping	Heaviest Section††	Operating	HP	CFM	HP	GPM		Gallons* Required	Conn. Size	Operating Weight (lbs)	Coil A	Upper U	Lower E	Height H	Length L
ATWB 4-3E9	4,050	3,380	6,250	(2) 2	18,110	1	200	76	180	6"	5,630	19-1/2"	5' 11-5/8"	3' 1-5/8"	9' 1-1/4"	8' 11-3/4"
ATWB 4-3F9	4,110	3,440	6,310	(2) 3	20,520	1	200	76	180	6"	5,690	19-1/2"	5' 11-5/8"	3' 1-5/8"	9' 1-1/4"	8' 11-3/4"
ATWB 4-4E9	4,600	3,930	6,990	(2) 2	17,580	1	200	99	180	6"	6,370	27"	6' 7-1/8"	3' 1-5/8"	9' 8-3/4"	8' 11-3/4"
ATWB 4-4F9	4,660	3,990	7,050	(2) 3	19,920	1	200	99	180	6"	6,430	27"	6' 7-1/8"	3' 1-5/8"	9' 8-3/4"	8' 11-3/4"
ATWB 4-5E9	5,190	4,520	7,780	(2) 2	17,060	1	200	122	180	6"	7,160	34-1/2"	7' 2-5/8"	3' 1-5/8"	10' 4-1/4"	8' 11-3/4"
ATWB 4-5F9	5,250	4,580	7,840	(2) 3	19,320	1	200	122	180	6"	7,220	34-1/2"	7' 2-5/8"	3' 1-5/8"	10' 4-1/4"	8' 11-3/4"
ATWB 4-3E12	4,890	4,070	7,790	(2) 2	21,990	1.5	270	100	230	8"	7,010	19-1/2"	5' 11-5/8"	3' 1-5/8"	9' 1-1/4"	11' 11-3/4"
ATWB 4-3F12	4,950	4,130	7,850	(2) 3	25,170	1.5	270	100	230	8"	7,070	19-1/2"	5' 11-5/8"	3' 1-5/8"	9' 1-1/4"	11' 11-3/4"
ATWB 4-3G12	4,970	4,150	7,870	(2) 5	29,190	1.5	270	100	230	8"	7,090	19-1/2"	5' 11-5/8"	3' 1-5/8"	9' 1-1/4"	11' 11-3/4"
ATWB 4-4E12	5,630	4,810	8,790	(2) 2	21,350	1.5	270	131	230	8"	8,010	27"	6' 7-1/8"	3' 1-5/8"	9' 8-3/4"	11' 11-3/4"
ATWB 4-4F12	5,690	4,870	8,850	(2) 3	24,440	1.5	270	131	230	8"	8,070	27"	6' 7-1/8"	3' 1-5/8"	9' 8-3/4"	11' 11-3/4"
ATWB 4-4G12	5,710	4,890	8,870	(2) 5	28,340	1.5	270	131	230	8"	8,090	27"	6' 7-1/8"	3' 1-5/8"	9' 8-3/4"	11' 11-3/4"
ATWB 4-5E12	6,430	5,610	9,850	(2) 2	20,710	1.5	270	162	230	8"	9,070	34-1/2"	7' 2-5/8"	3' 1-5/8"	10' 4-1/4"	11' 11-3/4"
ATWB 4-5F12	6,490	5,670	9,910	(2) 3	23,700	1.5	270	162	230	8"	9,130	34-1/2"	7' 2-5/8"	3' 1-5/8"	10' 4-1/4"	11' 11-3/4"
ATWB 4-5G12	6,510	5,690	9,930	(2) 5	27,490	1.5	270	162	230	8"	9,150	34-1/2"	7' 2-5/8"	3' 1-5/8"	10' 4-1/4"	11' 11-3/4"

† Model Numbers end in "-Z" for units with Series Flow piping configuration. Series Flow units may require additional coil connections and will require crossover piping. Model numbers will include "C" for units with Stainless Steel coil(s), "R" for units with Low Sound Fan(s) and "S" for units with an option that negates CTI certification.

†† Heaviest section is the coil/fan section.

\* Gallons shown is water in suspension in unit and piping. Allow for additional water in bottom of remote sump to cover pump suction and strainer during operation (12" would normally be sufficient).

△ When a remote sump arrangement is selected, the spray pump, suction strainer and associated piping are omitted; the unit is provided with an oversized outlet to facilitate drainage to the remote sump.

■ Unit dimensions and coil connections may vary slightly from catalog. See factory certified prints for dimensions, quantity of coil connections, and piping configuration. Coil connections are 4" bevel for weld (BFW). Other connection types such as grooved for mechanical coupling or flanged are also available as options.



# ATWB 7-3H9 to 7-7J9

Selections for ATWB Closed Circuit Coolers are available from EVAPCO's **SPECTRUM™** Program. Please contact your local sales representative for more information on the **SPECTRUM™** program.

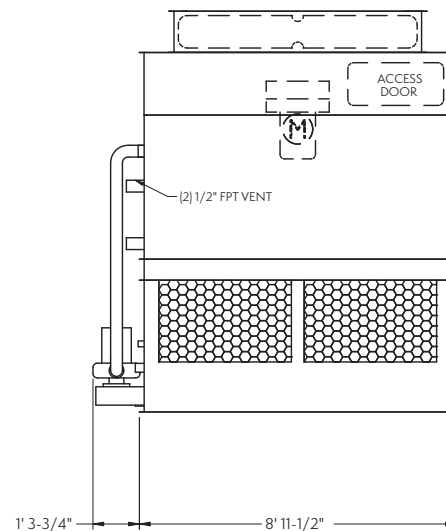
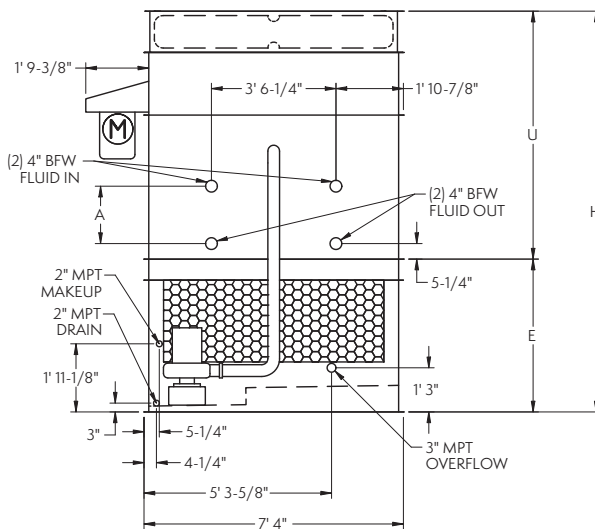
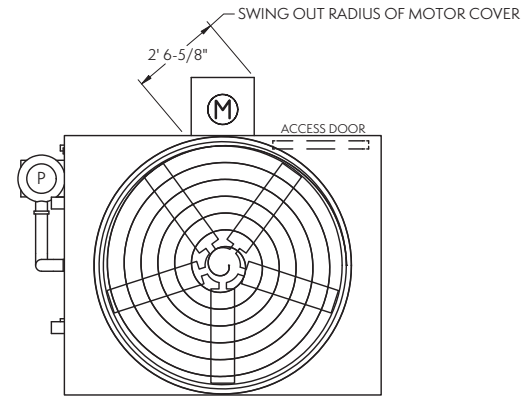

NOTE: The number of coil connections doubles when the flow rate exceeds 900 GPM on ATWB 7x9 models. This required option is referred to as the High Flow coil configuration.

ATWB Model Number†	Weights (lbs)			Fans		Spray Pump		Coil Volume (Gallons)	Remote Sump ▲			Dimensions ■			
	Shipping	Heaviest Section††	Operating	HP	CFM	HP	GPM		Gallons* Required	Conn. Size	Operating Weight (lbs)	Coil A	Upper U	Lower E	Height H
ATWB 7-3H9	7,550	5,960	10,080	7.5	34,120	2	410	144	120	8"	8,910	19-1/2"	7' 1/4"	4' 3-7/8"	11' 4-1/8"
ATWB 7-3I9	7,570	5,980	10,100	10	37,420	2	410	144	120	8"	8,930	19-1/2"	7' 1/4"	4' 3-7/8"	11' 4-1/8"
ATWB 7-4I9	8,600	7,010	11,490	10	36,330	2	410	188	120	8"	10,320	27"	7' 7-3/4"	4' 3-7/8"	11' 11-5/8"
ATWB 7-4J9	8,720	7,130	11,610	15	40,700	2	410	188	120	8"	10,440	27"	7' 7-3/4"	4' 3-7/8"	11' 11-5/8"
ATWB 7-5I9	9,700	8,110	12,960	10	35,240	2	410	232	120	8"	11,790	34-1/2"	8' 3-1/4"	4' 3-7/8"	12' 7-1/8"
ATWB 7-5J9	9,820	8,230	13,080	15	39,470	2	410	232	120	8"	11,910	34-1/2"	8' 3-1/4"	4' 3-7/8"	12' 7-1/8"
ATWB 7-6J9	10,880	9,290	14,500	15	38,250	2	410	276	120	8"	13,330	42"	8' 10-3/4"	4' 3-7/8"	13' 2-5/8"
ATWB 7-7J9	12,010	10,420	16,000	15	37,030	2	410	320	120	8"	14,830	47-3/4"	9' 4-1/2"	4' 3-7/8"	13' 8-3/8"

† Model Numbers end in "-Z" for units with Series Flow piping configuration. Series Flow units may require additional coil connections and will require crossover piping. Model numbers will include "C" for units with Stainless Steel coil(s), "R" for units with Low Sound Fan(s) and "S" for units with an option that negates CTI certification.

†† Heaviest section is the coil/fan section.

\* Gallons shown is water in suspension in unit and piping. Allow for additional water in bottom of remote sump to cover pump suction and strainer during operation (12" would normally be sufficient).

▲ When a remote sump arrangement is selected, the spray pump, suction strainer and associated piping are omitted; the unit is provided with an oversized outlet to facilitate drainage to the remote sump.

■ Unit dimensions and coil connections may vary slightly from catalog. See factory certified prints for dimensions, quantity of coil connections, and piping configuration. Coil connections are 4" bevel for weld (BFW). Other connection types such as grooved for mechanical coupling or flanged are also available as options.

# ATWB 7-3J12 to 7-7K12

Selections for ATWB Closed Circuit Coolers are available from EVAPCO's **SPECTRUM™** Program. Please contact your local sales representative for more information on the **SPECTRUM™** program.

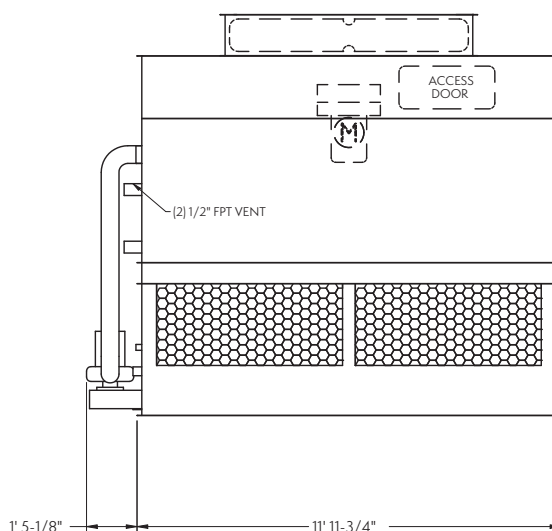
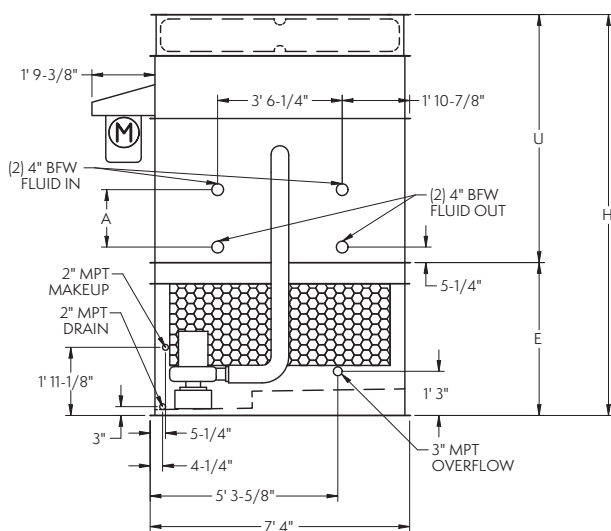
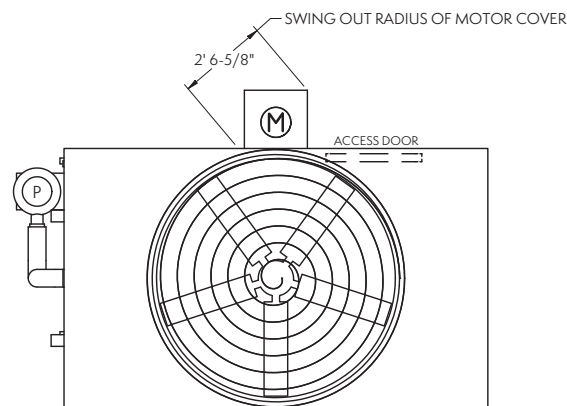

NOTE: The number of coil connections doubles when the flow rate exceeds 900 GPM on ATWB 7x12 models. This required option is referred to as the High Flow coil configuration.

ATWB Model Number†	Weights (lbs)			Fans		Spray Pump		Coil Volume (Gallons)	Remote Sump ◡			Dimensions ■			
	Shipping	Heaviest Section††	Operating	HP	CFM	HP	GPM		Gallons* Required	Conn. Size	Operating Weight (lbs)	Coil A	Upper U	Lower E	Height H
ATWB 7-3J12	9,270	7,370	12,760	15	51,680	3	550	189	160	10"	11,150	19-1/2"	7' 1/8"	4' 3-7/8"	11' 4-1/8"
ATWB 7-4J12	10,670	8,770	14,650	15	50,180	3	550	248	160	10"	13,040	27"	7' 7-5/8"	4' 3-7/8"	11' 11-5/8"
ATWB 7-5J12	12,050	10,150	16,520	15	48,670	3	550	307	160	10"	14,910	34-1/2"	8' 3-1/8"	4' 3-7/8"	12' 7-1/8"
ATWB 7-5K12	12,110	10,210	16,580	20	52,760	3	550	307	160	10"	14,970	34-1/2"	8' 3-1/8"	4' 3-7/8"	12' 7-1/8"
ATWB 7-6K12	13,530	11,630	18,490	20	51,130	3	550	366	160	10"	16,880	42"	8' 10-5/8"	4' 3-7/8"	13' 2-5/8"
ATWB 7-7K12	14,950	13,050	20,400	20	49,490	3	550	425	160	10"	18,790	47-3/4"	9' 4-3/8"	4' 3-7/8"	13' 8-3/8"

† Model Numbers end in "-Z" for units with Series Flow piping configuration. Series Flow units may require additional coil connections and will require crossover piping. Model numbers will include "C" for units with Stainless Steel coil(s), "R" for units with Low Sound Fan(s) and "S" for units with an option that negates CTI certification.

†† Heaviest section is the coil/fan section.

\* Gallons shown is water in suspension in unit and piping. Allow for additional water in bottom of remote sump to cover pump suction and strainer during operation (12" would normally be sufficient).

◡ When a remote sump arrangement is selected, the spray pump, suction strainer and associated piping are omitted; the unit is provided with an oversized outlet to facilitate drainage to the remote sump.

■ Unit dimensions and coil connections may vary slightly from catalog. See factory certified prints for dimensions, quantity of coil connections, and piping configuration. Coil connections are 4" bevel for weld (BFW). Other connection types such as grooved for mechanical coupling or flanged are also available as options.

# ATWB 7-3J14 to 7-7L14

Selections for ATWB Closed Circuit Coolers are available from EVAPCO's **SPECTRUM™** Program. Please contact your local sales representative for more information on the **SPECTRUM™** program.

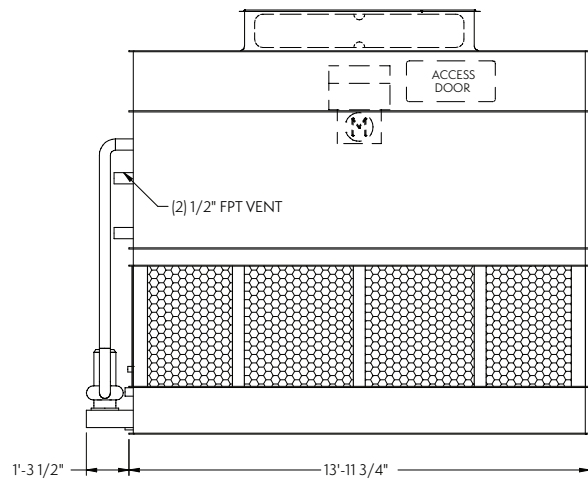
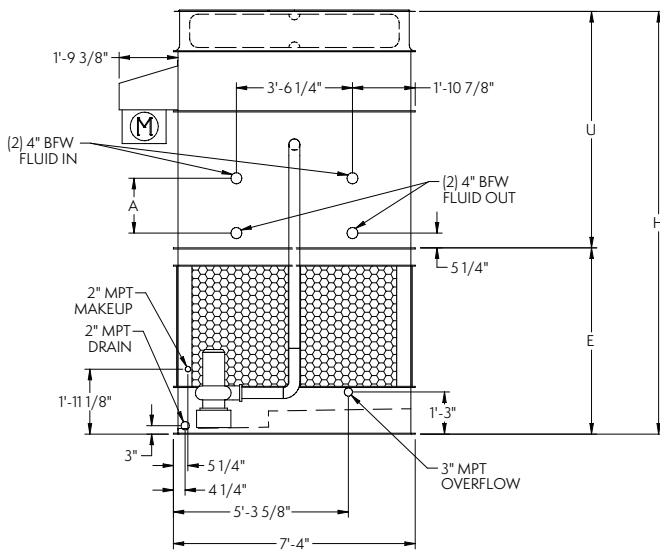
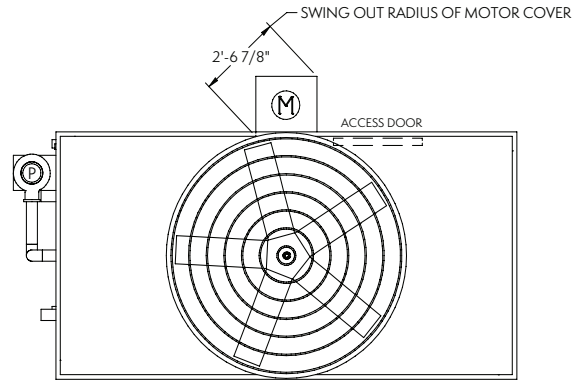

NOTE: The number of coil connections doubles when the flow rate exceeds 900 GPM on ATWB 7x14 models. This required option is referred to as the High Flow coil configuration.

ATWB Model Number†	Weights (lbs)			Fans		Spray Pump		Coil Volume (Gallons)	Remote Sump ▲			Dimensions ■			
	Shipping	Heaviest Section††	Operating	HP	CFM	HP	GPM		Gallons* Required	Conn. Size	Operating Weight (lbs)	Coil A	Upper U	Lower E	Height H
ATWB 7-3J14	10,570	8,380	14,570	15	57,760	3	600	219	190	10"	12,760	19-1/2"	7' 1/4"	4' 8-1/4"	11' 8-1/2"
ATWB 7-4J14	12,180	9,990	16,760	15	56,080	3	600	288	190	10"	14,950	27"	7' 7-3/4"	4' 8-1/4"	12' 4"
ATWB 7-5J14	13,840	11,650	18,990	15	54,400	3	600	357	190	10"	17,180	34-1/2"	8' 3-1/4"	4' 8-1/4"	12' 11-1/2"
ATWB 7-5K14	13,900	11,710	19,050	20	58,960	3	600	357	190	10"	17,240	34-1/2"	8' 3-1/4"	4' 8-1/4"	12' 11-1/2"
ATWB 7-6K14	15,550	13,360	21,270	20	57,140	3	600	426	190	10"	19,460	42"	8' 10-3/4"	4' 8-1/4"	13' 7"
ATWB 7-6L14	15,580	13,390	21,300	25	60,820	3	600	426	190	10"	19,490	42"	8' 10-3/4"	4' 8-1/4"	13' 7"
ATWB 7-7L14	15,610	13,420	21,910	25	58,880	3	600	495	190	10"	20,100	47-3/4"	9' 4-1/2"	4' 8-1/4"	14' 3/4"

† Model Numbers end in "-Z" for units with Series Flow piping configuration. Series Flow units may require additional coil connections and will require crossover piping. Model numbers will include "C" for units with Stainless Steel coil(s), "R" for units with Low Sound Fan(s) and "S" for units with an option that negates CTI certification.

†† Heaviest section is the coil/fan section.

\* Gallons shown is water in suspension in unit and piping. Allow for additional water in bottom of remote sump to cover pump suction and strainer during operation (12" would normally be sufficient).

▲ When a remote sump arrangement is selected, the spray pump, suction strainer and associated piping are omitted; the unit is provided with an oversized outlet to facilitate drainage to the remote sump.

■ Unit dimensions and coil connections may vary slightly from catalog. See factory certified prints for dimensions, quantity of coil connections, and piping configuration. Coil connections are 4" bevel for weld (BFW). Other connection types such as grooved for mechanical coupling or flanged are also available as options.



# ATWB 7-3H18 to 7-7J18

Selections for ATWB Closed Circuit Coolers are available from EVAPCO's **SPECTRUM™** Program. Please contact your local sales representative for more information on the **SPECTRUM™** program.

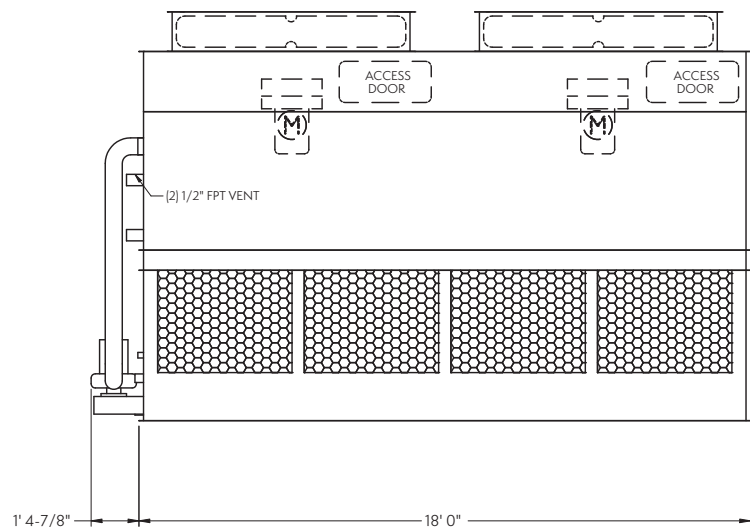
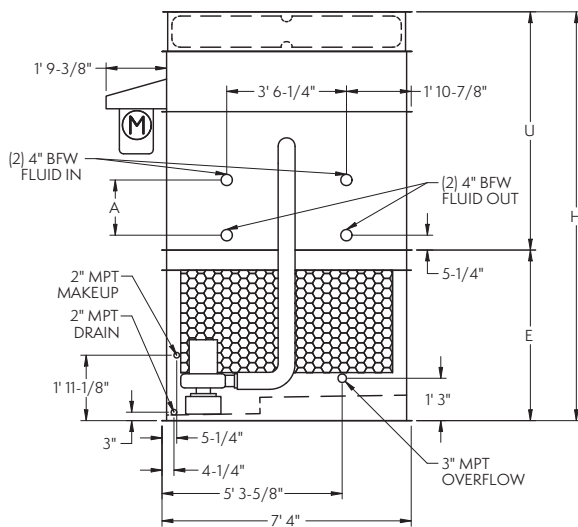
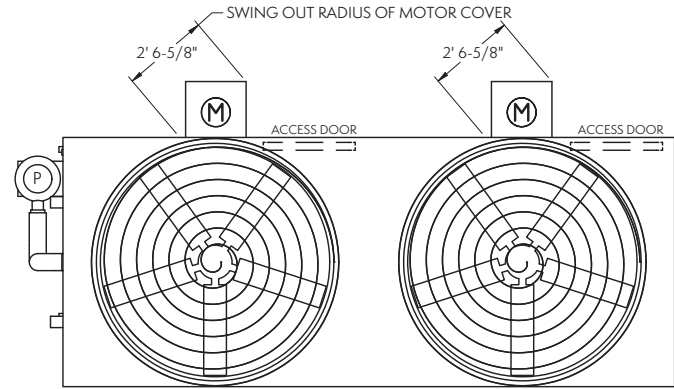

NOTE: The number of coil connections doubles when the flow rate exceeds 900 GPM on ATWB 7x18 models. This required option is referred to as the High Flow coil configuration.

ATWB Model Number†	Weights (lbs)			Fans		Spray Pump		Coil Volume (Gallons)	Remote Sump $\Delta$			Dimensions $\blacksquare$			
	Shipping	Heaviest Section††	Operating	HP	CFM	HP	GPM		Gallons* Required	Conn. Size	Operating Weight (lbs)	Coil A	Upper U	Lower E	Height H
ATWB 7-3H18	13,970	10,950	19,260	(2) 7.5	68,480	5	800	279	240	12"	16,880	19-1/2"	7' 1/4"	5' 1/4"	12' 1/2"
ATWB 7-3I18	14,000	10,980	19,290	(2) 10	75,120	5	800	279	240	12"	16,910	19-1/2"	7' 1/4"	5' 1/4"	12' 1/2"
ATWB 7-4H18	16,070	13,050	22,100	(2) 7.5	66,490	5	800	368	240	12"	19,720	27"	7' 7-3/4"	5' 1/4"	12' 8"
ATWB 7-4I18	16,100	13,080	22,130	(2) 10	72,930	5	800	368	240	12"	19,750	27"	7' 7-3/4"	5' 1/4"	12' 8"
ATWB 7-4J18	16,350	13,330	22,380	(2) 15	81,700	5	800	368	240	12"	20,000	27"	7' 7-3/4"	5' 1/4"	12' 8"
ATWB 7-5H18	18,180	15,160	24,950	(2) 7.5	64,490	5	800	457	240	12"	22,570	34-1/2"	8' 3-1/4"	5' 1/4"	13' 3-1/2"
ATWB 7-5I18	18,210	15,190	24,980	(2) 10	70,740	5	800	457	240	12"	22,600	34-1/2"	8' 3-1/4"	5' 1/4"	13' 3-1/2"
ATWB 7-5J18	18,460	15,440	25,230	(2) 15	79,250	5	800	457	240	12"	22,850	34-1/2"	8' 3-1/4"	5' 1/4"	13' 3-1/2"
ATWB 7-6H18	20,350	17,330	27,870	(2) 7.5	62,500	5	800	546	240	12"	25,490	42"	8' 10-3/4"	5' 1/4"	13' 11"
ATWB 7-6I18	20,380	17,360	27,900	(2) 10	68,560	5	800	546	240	12"	25,520	42"	8' 10-3/4"	5' 1/4"	13' 11"
ATWB 7-6J18	20,630	17,610	28,150	(2) 15	76,800	5	800	546	240	12"	25,770	42"	8' 10-3/4"	5' 1/4"	13' 11"
ATWB 7-7I18	22,540	19,520	30,800	(2) 10	66,370	5	800	635	240	12"	28,420	47-3/4"	9' 4-1/2"	5' 1/4"	14' 4-3/4"
ATWB 7-7J18	22,790	19,770	31,050	(2) 15	74,350	5	800	635	240	12"	28,670	47-3/4"	9' 4-1/2"	5' 1/4"	14' 4-3/4"

† Model Numbers end in "-Z" for units with Series Flow piping configuration. Series Flow units may require additional coil connections and will require crossover piping. Model numbers will include "C" for units with Stainless Steel coil(s), "R" for units with Low Sound Fan(s) and "S" for units with an option that negates CTI certification.

†† Heaviest section is the coil/fan section.

\* Gallons shown is water in suspension in unit and piping. Allow for additional water in bottom of remote sump to cover pump suction and strainer during operation (12" would normally be sufficient).

$\Delta$  When a remote sump arrangement is selected, the spray pump, suction strainer and associated piping are omitted; the unit is provided with an oversized outlet to facilitate drainage to the remote sump.

$\blacksquare$  Unit dimensions and coil connections may vary slightly from catalog. See factory certified prints for dimensions, quantity of coil connections, and piping configuration. Coil connections are 4" bevel for weld (BFW). Other connection types such as grooved for mechanical coupling or flanged are also available as options.

# ATWB 7-3J24 to 7-7K24

Selections for ATWB Closed Circuit Coolers are available from EVAPCO's **SPECTRUM™** Program. Please contact your local sales representative for more information on the **SPECTRUM™** program.

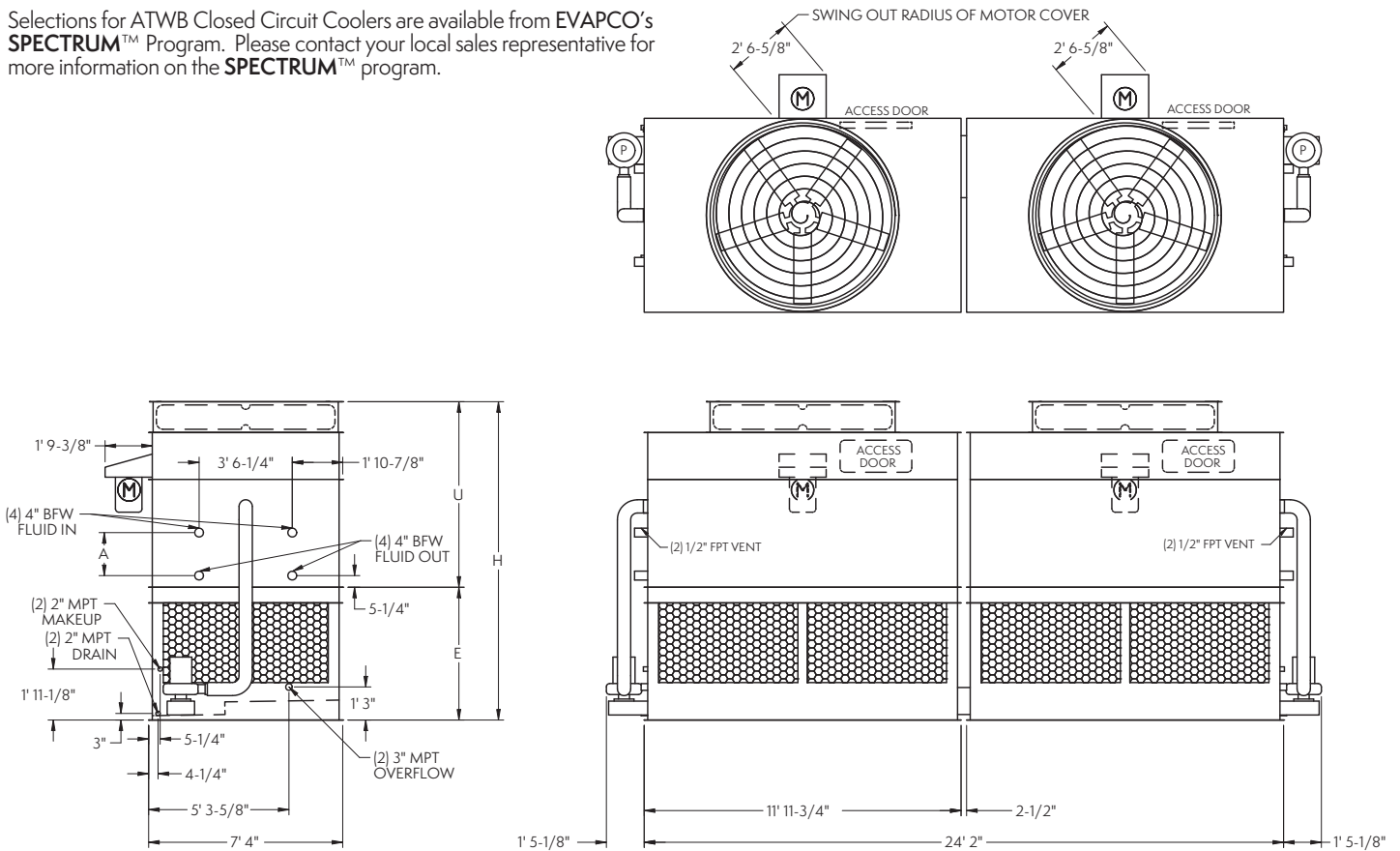

NOTE: The number of coil connections doubles when the flow rate exceeds 1,800 GPM on ATWB 7x24 models. This required option is referred to as the High Flow coil configuration.

ATWB Model Number†	Weights (lbs)			Fans		Spray Pump		Coil Volume (Gallons)	Remote Sump ▲			Dimensions ■			
	Shipping	Heaviest Section††	Operating	HP	CFM	HP	GPM		Gallons* Required	Conn. Size	Operating Weight (lbs)	Coil A	Upper U	Lower E	Height H
ATWB 7-3J24	18,540	7,370	25,520	(2) 15	103,370	(2) 3	550	378	310	(2) 10"	21,000	19-1/2"	7' 1/4"	5' 1/4"	12' 1/2"
ATWB 7-4J24	21,340	8,770	29,300	(2) 15	100,360	(2) 3	550	496	310	(2) 10"	24,780	27"	7' 7-3/4"	5' 1/4"	12' 8"
ATWB 7-5J24	24,100	10,150	33,040	(2) 15	97,350	(2) 3	550	614	310	(2) 10"	28,520	34-1/2"	8' 3-1/4"	5' 1/4"	13' 3-1/2"
ATWB 7-5K24	24,220	10,210	33,160	(2) 20	105,510	(2) 3	550	614	310	(2) 10"	28,640	34-1/2"	8' 3-1/4"	5' 1/4"	13' 3-1/2"
ATWB 7-6K24	27,060	11,630	36,980	(2) 20	102,250	(2) 3	550	731	310	(2) 10"	32,460	42"	8' 10-3/4"	5' 1/4"	13' 11"
ATWB 7-7K24	29,900	13,050	40,800	(2) 20	98,990	(2) 3	550	849	310	(2) 10"	36,280	47-3/4"	9' 4-1/2"	5' 1/4"	14' 4-3/4"

† Model Numbers end in "-Z" for units with Series Flow piping configuration. Series Flow units may require additional coil connections and will require crossover piping. Model numbers will include "C" for units with Stainless Steel coil(s), "R" for units with Low Sound Fan(s) and "S" for units with an option that negates CTI certification.

†† Heaviest section is the coil/fan section.

\* Gallons shown is water in suspension in unit and piping. Allow for additional water in bottom of remote sump to cover pump suction and strainer during operation (12" would normally be sufficient).

▲ When a remote sump arrangement is selected, the spray pump, suction strainer and associated piping are omitted; the unit is provided with an oversized outlet to facilitate drainage to the remote sump.

■ Unit dimensions and coil connections may vary slightly from catalog. See factory certified prints for dimensions, quantity of coil connections, and piping configuration. Coil connections are 4" bevel for weld (BFW). Other connection types such as grooved for mechanical coupling or flanged are also available as options.

# ATWB 7-3J28 to 7-7L28

Selections for ATWB Closed Circuit Coolers are available from EVAPCO's **SPECTRUM™** Program. Please contact your local sales representative for more information on the **SPECTRUM™** program.

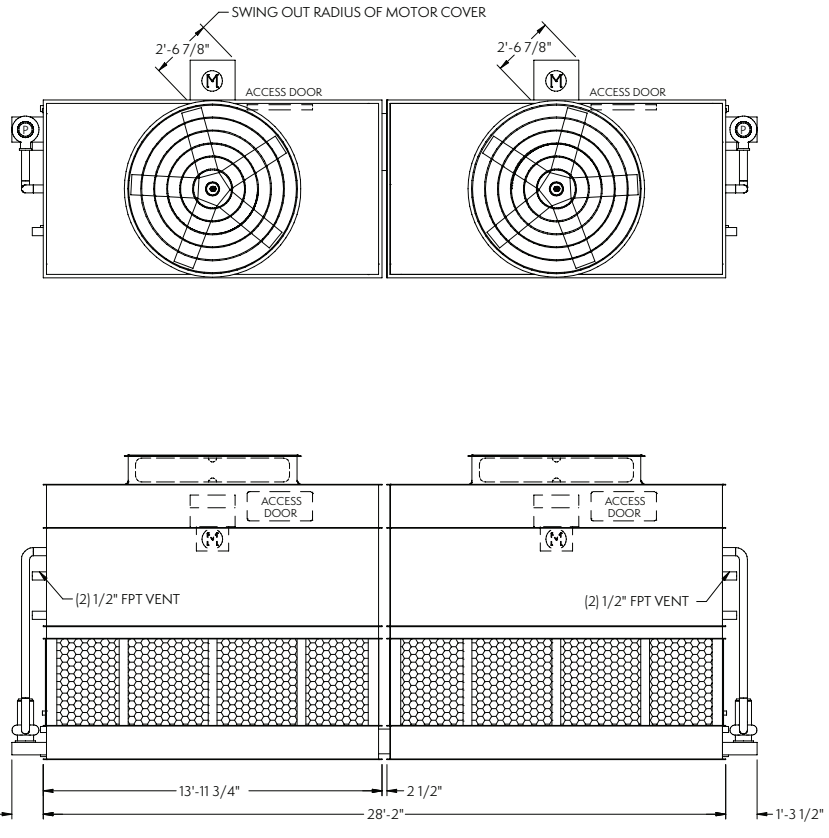

NOTE: The number of coil connections doubles when the flow rate exceeds 1,800 GPM on ATWB 7x28 models. This required option is referred to as the High Flow coil configuration.

ATWB Model Number†	Weights (lbs)			Fans		Spray Pump		Coil Volume (Gallons)	Remote Sump △			Dimensions ■			
	Shipping	Heaviest Section††	Operating	HP	CFM	HP	GPM		Gallons* Required	Conn. Size	Operating Weight (lbs)	Coil A	Upper U	Lower E	Height H
ATWB 7-3J28	21,140	8,380	29,140	(2) 15	115,530	(2) 3	600	438	190	10"	23,960	19-1/2"	7' 1/4"	5' 6-1/4"	12' 6-1/2"
ATWB 7-4J28	24,360	9,990	33,520	(2) 15	112,160	(2) 3	600	576	190	10"	28,340	27"	7' 7-3/4"	5' 6-1/4"	13' 2"
ATWB 7-5J28	27,680	11,650	37,980	(2) 15	108,800	(2) 3	600	714	190	10"	32,800	34-1/2"	8' 3-1/4"	5' 6-1/4"	13' 9-1/2"
ATWB 7-5K28	27,800	11,710	38,100	(2) 20	117,930	(2) 3	600	714	190	10"	32,920	34-1/2"	8' 3-1/4"	5' 6-1/4"	13' 9-1/2"
ATWB 7-6K28	31,100	13,360	42,540	(2) 20	114,280	(2) 3	600	851	190	10"	37,360	42"	8' 10-3/4"	5' 6-1/4"	14' 5"
ATWB 7-6L28	31,160	13,390	42,600	(2) 25	121,650	(2) 3	600	851	190	10"	37,420	42"	8' 10-3/4"	5' 6-1/4"	14' 5"
ATWB 7-7L28	31,220	13,420	43,820	(2) 25	117,760	(2) 3	600	989	190	10"	38,640	47-3/4"	9' 4-1/2"	5' 6-1/4"	14' 10-3/4"

† Model Numbers end in "-Z" for units with Series Flow piping configuration. Series Flow units may require additional coil connections and will require crossover piping. Model numbers will include "C" for units with Stainless Steel coil(s), "R" for units with Low Sound Fan(s) and "S" for units with an option that negates CTI certification.

†† Heaviest section is the coil/fan section.

\* Gallons shown is water in suspension in unit and piping. Allow for additional water in bottom of remote sump to cover pump suction and strainer during operation (12" would normally be sufficient).

△ When a remote sump arrangement is selected, the spray pump, suction strainer and associated piping are omitted; the unit is provided with an oversized outlet to facilitate drainage to the remote sump.

■ Unit dimensions and coil connections may vary slightly from catalog. See factory certified prints for dimensions, quantity of coil connections, and piping configuration. Coil connections are 4" bevel for weld (BFW). Other connection types such as grooved for mechanical coupling or flanged are also available as options.



# ATWB 7-3H36 to 7-7J36

Selections for ATWB Closed Circuit Coolers are available from EVAPCO's SPECTRUM™ Program. Please contact your local sales representative for more information on the SPECTRUM™ program.

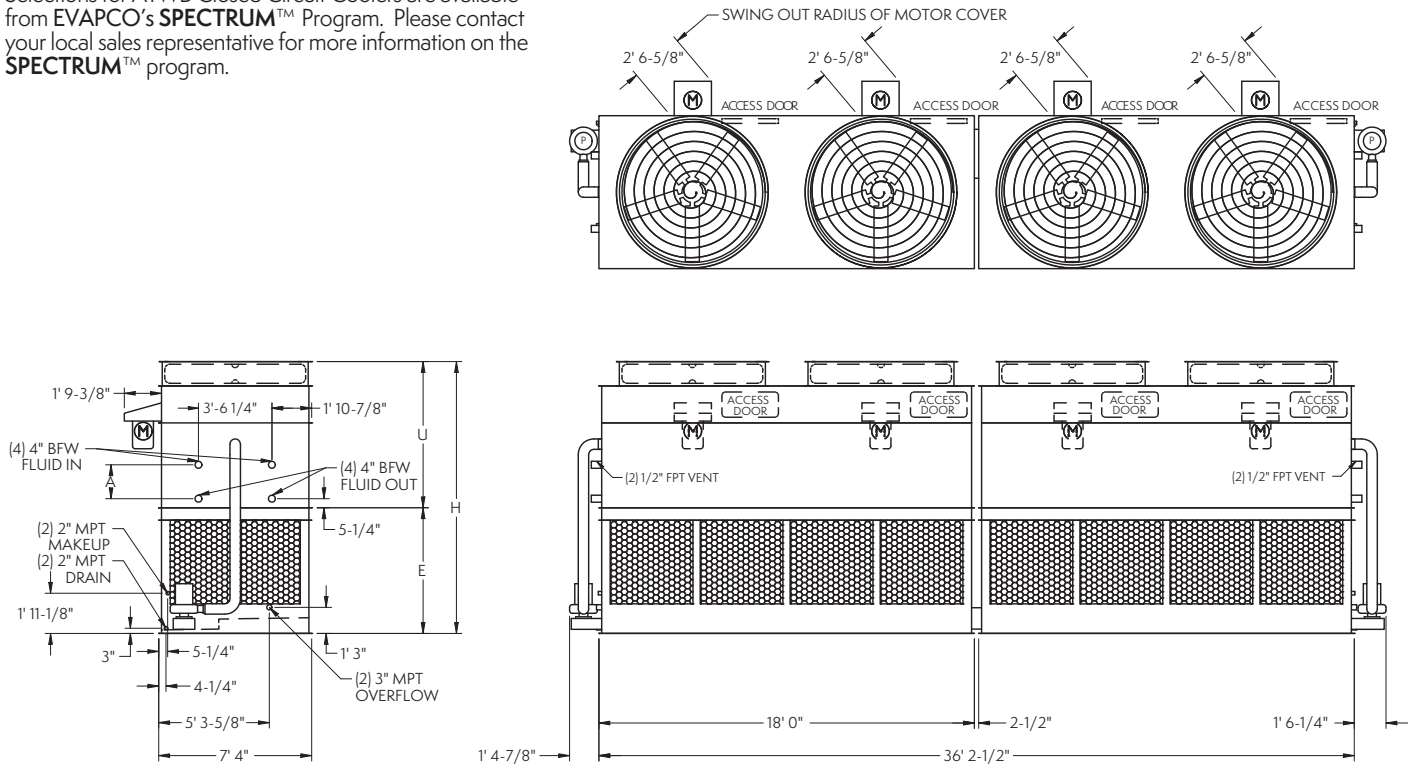

NOTE: The number of coil connections doubles when the flow rate exceeds 1,800 GPM on ATWB 7x36 models. This required option is referred to as the High Flow coil configuration.

ATWB Model Number†	Weights (lbs)			Fans		Spray Pump		Coil Volume (Gallons)	Remote Sump △			Dimensions ■			
	Shipping	Heaviest Section††	Operating	HP	CFM	HP	GPM		Gallons* Required	Conn. Size	Operating Weight (lbs)	Coil A	Upper U	Lower E	Height H
ATWB 7-3H36	27,940	10,950	38,520	(4) 7.5	136,960	(2) 5	800	558	480	(2) 12"	31,780	19-1/2"	7' 1/4"	6' 1/4"	13' 1/2"
ATWB 7-3I36	28,000	10,980	38,580	(4) 10	150,240	(2) 5	800	558	480	(2) 12"	31,840	19-1/2"	7' 1/4"	6' 1/4"	13' 1/2"
ATWB 7-4H36	32,140	13,050	44,200	(4) 7.5	132,970	(2) 5	800	736	480	(2) 12"	37,460	27"	7' 7-3/4"	6' 1/4"	13' 8"
ATWB 7-4I36	32,200	13,080	44,260	(4) 10	145,860	(2) 5	800	736	480	(2) 12"	37,520	27"	7' 7-3/4"	6' 1/4"	13' 8"
ATWB 7-4J36	32,700	13,330	44,760	(4) 15	163,400	(2) 5	800	736	480	(2) 12"	38,020	27"	7' 7-3/4"	6' 1/4"	13' 8"
ATWB 7-5H36	36,360	15,160	49,900	(4) 7.5	128,980	(2) 5	800	914	480	(2) 12"	43,160	34-1/2"	8' 3-1/4"	6' 1/4"	14' 3-1/2"
ATWB 7-5I36	36,420	15,190	49,960	(4) 10	141,490	(2) 5	800	914	480	(2) 12"	43,220	34-1/2"	8' 3-1/4"	6' 1/4"	14' 3-1/2"
ATWB 7-5J36	36,920	15,440	50,460	(4) 15	158,500	(2) 5	800	914	480	(2) 12"	43,720	34-1/2"	8' 3-1/4"	6' 1/4"	14' 3-1/2"
ATWB 7-6H36	40,700	17,330	55,740	(4) 7.5	124,990	(2) 5	800	1091	480	(2) 12"	49,000	42"	8' 10-3/4"	6' 1/4"	14' 11"
ATWB 7-6I36	40,760	17,360	55,800	(4) 10	137,110	(2) 5	800	1091	480	(2) 12"	49,060	42"	8' 10-3/4"	6' 1/4"	14' 11"
ATWB 7-6J36	41,260	17,610	56,300	(4) 15	153,600	(2) 5	800	1091	480	(2) 12"	49,560	42"	8' 10-3/4"	6' 1/4"	14' 11"
ATWB 7-7I36	45,080	19,520	61,600	(4) 10	132,740	(2) 5	800	1269	480	(2) 12"	54,860	47-3/4"	9' 4-1/2"	6' 1/4"	15' 4-3/4"
ATWB 7-7J36	45,580	19,770	62,100	(4) 15	148,700	(2) 5	800	1269	480	(2) 12"	55,360	47-3/4"	9' 4-1/2"	6' 1/4"	15' 4-3/4"

† Model Numbers end in "-Z" for units with Series Flow piping configuration. Series Flow units may require additional coil connections and will require crossover piping. Model numbers will include "C" for units with Stainless Steel coil(s), "R" for units with Low Sound Fan(s) and "S" for units with an option that negates CTI certification.

†† Heaviest section is the coil/fan section.

\* Gallons shown is water in suspension in unit and piping. Allow for additional water in bottom of remote sump to cover pump suction and strainer during operation (12" would normally be sufficient).

△ When a remote sump arrangement is selected, the spray pump, suction strainer and associated piping are omitted; the unit is provided with an oversized outlet to facilitate drainage to the remote sump.

■ Unit dimensions and coil connections may vary slightly from catalog. See factory certified prints for dimensions, quantity of coil connections, and piping configuration. Coil connections are 4" bevel for weld (BFW). Other connection types such as grooved for mechanical coupling or flanged are also available as options.

# ATWB 14-3H9 to 14-7J9

Selections for ATWB Closed Circuit Coolers are available from EVAPCO's **SPECTRUM™** Program. Please contact your local sales representative for more information on the **SPECTRUM™** program.

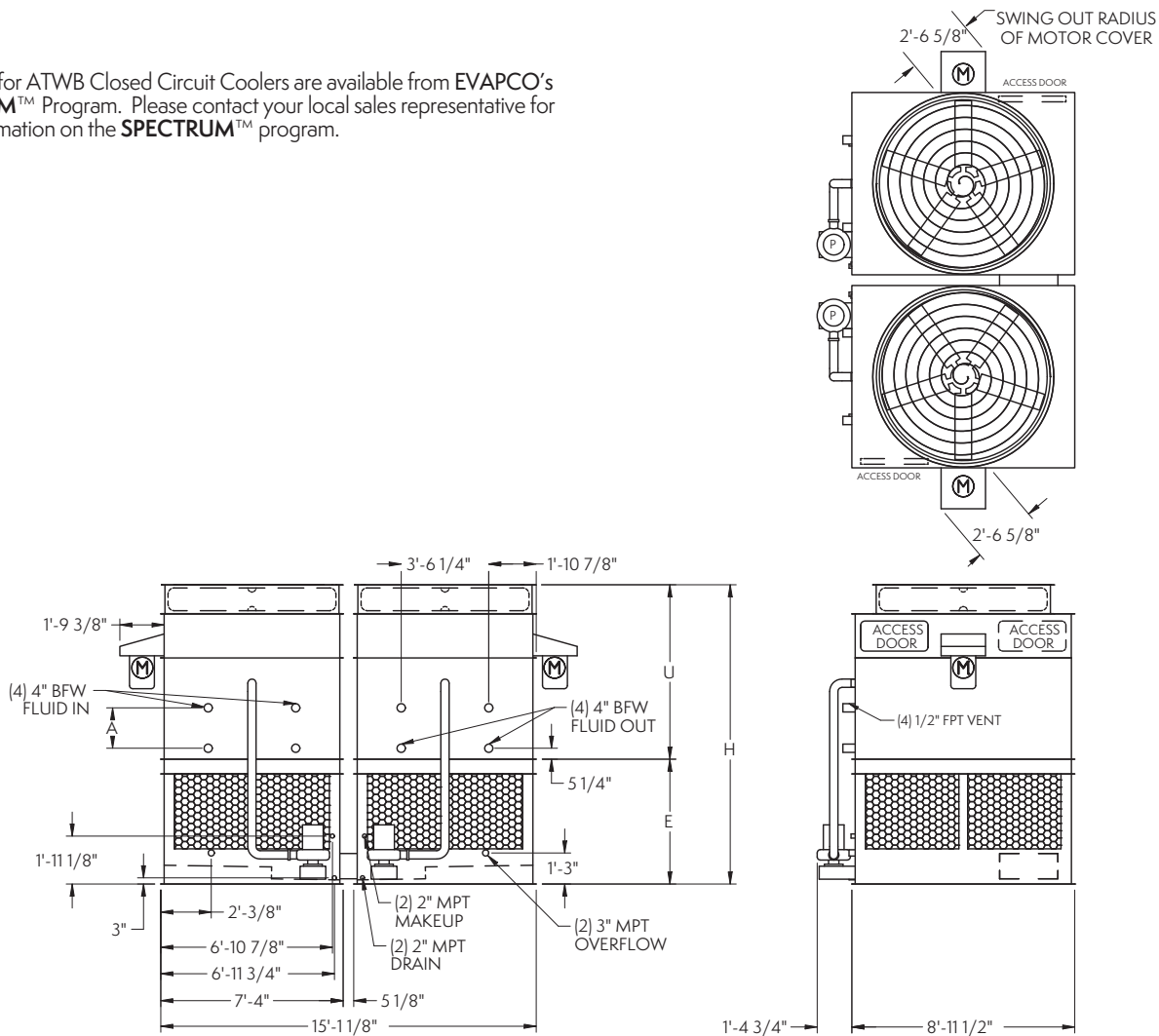

NOTE: The number of coil connections doubles when the flow rate exceeds 1,800 GPM on ATWB 14x9 models. This required option is referred to as the High Flow coil configuration.

ATWB Model Number†	Weights (lbs)			Fans		Spray Pump		Coil Volume (Gallons)	Remote Sump $\Delta$			Dimensions $\blacksquare$			
	Shipping	Heaviest Section††	Operating	HP	CFM	HP	GPM		Gallons* Required	Conn. Size	Operating Weight (lbs)	Coil A	Upper U	Lower E	Height H
ATWB 14-3H9	15,100	5,960	20,160	(2) 7.5	68,240	(2) 2	410	288	240	(2) 8"	16,820	19-1/2"	7' 1/4"	5' 1/4"	12' 1/2"
ATWB 14-3I9	15,140	5,980	20,200	(2) 10	74,830	(2) 2	410	288	240	(2) 8"	16,860	19-1/2"	7' 1/4"	5' 1/4"	12' 1/2"
ATWB 14-4I9	17,200	7,010	22,980	(2) 10	72,660	(2) 2	410	376	240	(2) 8"	19,640	27"	7' 7-3/4"	5' 1/4"	12' 8"
ATWB 14-4J9	17,440	7,130	23,220	(2) 15	81,390	(2) 2	410	376	240	(2) 8"	19,880	27"	7' 7-3/4"	5' 1/4"	12' 8"
ATWB 14-5I9	19,400	8,110	25,920	(2) 10	78,950	(2) 2	410	463	240	(2) 8"	22,580	34-1/2"	8' 3-1/4"	5' 1/4"	13' 3-1/2"
ATWB 14-5J9	19,640	8,230	26,160	(2) 15	78,950	(2) 2	410	463	240	(2) 8"	22,820	34-1/2"	8' 3-1/4"	5' 1/4"	13' 3-1/2"
ATWB 14-6J9	21,760	9,290	29,000	(2) 15	76,510	(2) 2	410	551	240	(2) 8"	25,660	42"	8' 10-3/4"	5' 1/4"	13' 1"
ATWB 14-7J9	24,020	10,420	32,000	(2) 15	74,070	(2) 2	410	639	240	(2) 8"	28,660	47-3/4"	9' 4-1/2"	5' 1/4"	14' 4-3/4"

† Model Numbers end in "-Z" for units with Series Flow piping configuration. Series Flow units may require additional coil connections and will require crossover piping. Model numbers will include "C" for units with Stainless Steel coil(s), "R" for units with Low Sound Fan(s) and "S" for units with an option that negates CTI certification.

†† Heaviest section is the coil/fan section.

\* Gallons shown is water in suspension in unit and piping. Allow for additional water in bottom of remote sump to cover pump suction and strainer during operation (12" would normally be sufficient).

$\Delta$  When a remote sump arrangement is selected, the spray pump, suction strainer and associated piping are omitted; the unit is provided with an oversized outlet to facilitate drainage to the remote sump.

$\blacksquare$  Unit dimensions and coil connections may vary slightly from catalog. See factory certified prints for dimensions, quantity of coil connections, and piping configuration. Coil connections are 4" bevel for weld (BFW). Other connection types such as grooved for mechanical coupling or flanged are also available as options.

# ATWB 14-3J12 to 14-7K12

Selections for ATWB Closed Circuit Coolers are available from EVAPCO's **SPECTRUM™** Program. Please contact your local sales representative for more information on the **SPECTRUM™** program.

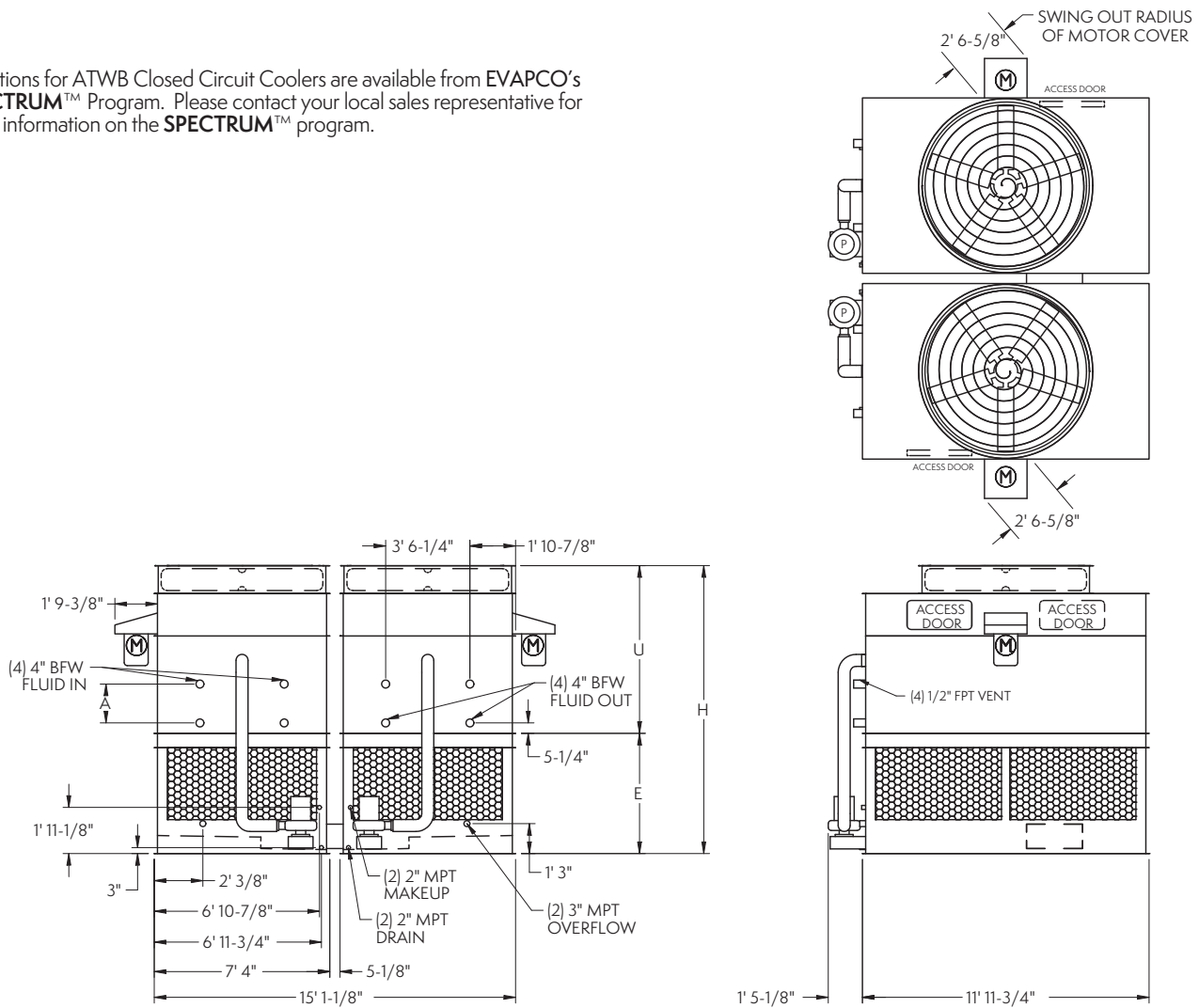

NOTE: The number of coil connections doubles when the flow rate exceeds 1,800 GPM on ATWB 14x12 models. This required option is referred to as the High Flow coil configuration.

ATWB Model Number†	Weights (lbs)			Fans		Spray Pump		Coil Volume (Gallons)	Remote Sump △			Dimensions ■			
	Shipping	Heaviest Section††	Operating	HP	CFM	HP	GPM		Gallons* Required	Conn. Size	Operating Weight (lbs)	Coil A	Upper U	Lower E	Height H
ATWB 14-3J12	18,540	7,370	25,520	(2) 15	103,370	(2) 3	550	378	310	(2) 10"	21,000	19-1/2"	7' 1/4"	5' 1/4"	12' 1/2"
ATWB 14-4J12	21,340	8,770	29,300	(2) 15	100,360	(2) 3	550	496	310	(2) 10"	24,780	27"	7' 7-3/4"	5' 1/4"	12' 8"
ATWB 14-5J12	24,100	10,150	33,040	(2) 15	97,350	(2) 3	550	614	310	(2) 10"	28,520	34-1/2"	8' 3-1/4"	5' 1/4"	13' 3-1/2"
ATWB 14-5K12	24,220	10,210	33,160	(2) 20	105,510	(2) 3	550	614	310	(2) 10"	28,640	34-1/2"	8' 3-1/4"	5' 1/4"	13' 3-1/2"
ATWB 14-6K12	27,060	11,630	36,980	(2) 20	102,250	(2) 3	550	731	310	(2) 10"	32,460	42"	8' 10-3/4"	5' 1/4"	13' 11"
ATWB 14-7K12	29,900	13,050	40,800	(2) 20	98,990	(2) 3	550	849	310	(2) 10"	36,280	47-3/4"	9' 4-1/2"	5' 1/4"	14' 4-3/4"

† Model Numbers end in "-Z" for units with Series Flow piping configuration. Series Flow units may require additional coil connections and will require crossover piping. Model numbers will include "C" for units with Stainless Steel coil(s), "R" for units with Low Sound Fan(s) and "S" for units with an option that negates CTI certification.

†† Heaviest section is the coil/fan section.

\* Gallons shown is water in suspension in unit and piping. Allow for additional water in bottom of remote sump to cover pump suction and strainer during operation (12" would normally be sufficient).

△ When a remote sump arrangement is selected, the spray pump, suction strainer and associated piping are omitted; the unit is provided with an oversized outlet to facilitate drainage to the remote sump.

■ Unit dimensions and coil connections may vary slightly from catalog. See factory certified prints for dimensions, quantity of coil connections, and piping configuration. Coil connections are 4" bevel for weld (BFW). Other connection types such as grooved for mechanical coupling or flanged are also available as options.



# ATWB 14-3J14 to 14-7L14

Selections for ATWB Closed Circuit Coolers are available from EVAPCO's **SPECTRUM™** Program. Please contact your local sales representative for more information on the **SPECTRUM™** program.

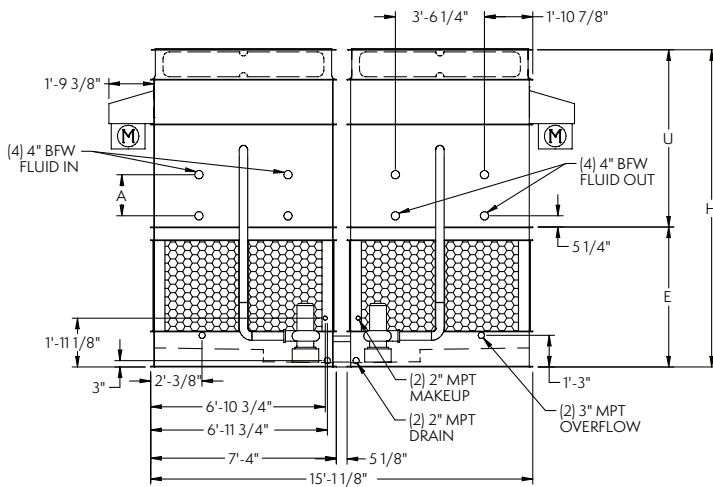
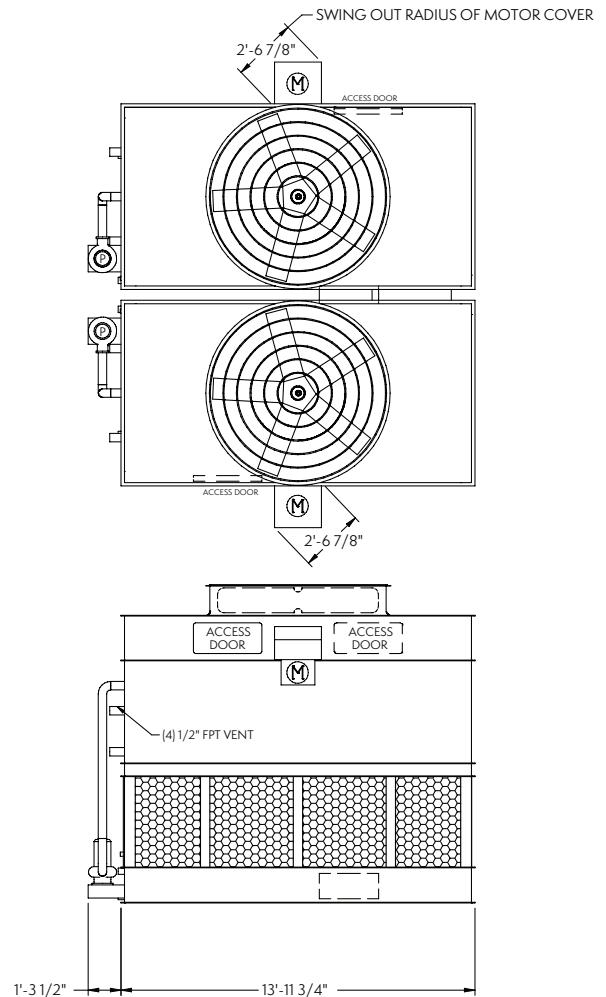

NOTE: The number of coil connections doubles when the flow rate exceeds 1,800 GPM on ATWB 14x14 models. This required option is referred to as the High Flow coil configuration.

ATWB Model Number†	Weights (lbs)			Fans		Spray Pump		Coil Volume (Gallons)	Remote Sump ▲			Dimensions ■			
	Shipping	Heaviest Section††	Operating	HP	CFM	HP	GPM		Gallons* Required	Conn. Size	Operating Weight (lbs)	Coil A	Upper U	Lower E	Height H
ATWB 14-3J14	21,140	8,380	29,140	(2) 15	115,530	(2) 3	600	438	190	10"	23,960	19'-1/2"	7'-1/4"	5'-6-1/4"	12'-6-1/2"
ATWB 14-4J14	24,360	9,990	33,520	(2) 15	112,160	(2) 3	600	576	190	10"	28,340	27"	7'-7-3/4"	5'-6-1/4"	13'-2"
ATWB 14-5J14	27,680	11,650	37,980	(2) 15	108,800	(2) 3	600	714	190	10"	32,800	34'-1/2"	8'-3-1/4"	5'-6-1/4"	13'-9-1/2"
ATWB 14-5K14	27,800	11,710	38,100	(2) 20	117,930	(2) 3	600	714	190	10"	32,920	34'-1/2"	8'-3-1/4"	5'-6-1/4"	13'-9-1/2"
ATWB 14-6K14	31,100	13,360	42,540	(2) 20	114,280	(2) 3	600	851	190	10"	37,360	42"	8'-10-3/4"	5'-6-1/4"	14'-5"
ATWB 14-6L14	31,160	13,390	42,600	(2) 25	121,650	(2) 3	600	851	190	10"	37,420	42"	8'-10-3/4"	5'-6-1/4"	14'-5"
ATWB 14-7L14	31,220	13,420	43,820	(2) 25	117,760	(2) 3	600	989	190	10"	38,640	47'-3/4"	9'-4-1/2"	5'-6-1/4"	14'-10-3/4"

† Model Numbers end in "-Z" for units with Series Flow piping configuration. Series Flow units may require additional coil connections and will require crossover piping. Model numbers will include "C" for units with Stainless Steel coil(s), "R" for units with Low Sound Fan(s) and "S" for units with an option that negates CTI certification.

†† Heaviest section is the coil/fan section.

\* Gallons shown is water in suspension in unit and piping. Allow for additional water in bottom of remote sump to cover pump suction and strainer during operation (12" would normally be sufficient).

▲ When a remote sump arrangement is selected, the spray pump, suction strainer and associated piping are omitted; the unit is provided with an oversized outlet to facilitate drainage to the remote sump.

■ Unit dimensions and coil connections may vary slightly from catalog. See factory certified prints for dimensions, quantity of coil connections, and piping configuration. Coil connections are 4" bevel for weld (BFW). Other connection types such as grooved for mechanical coupling or flanged are also available as options.

# ATWB 14-3H18 to 14-7J18

Selections for ATWB Closed Circuit Coolers are available from EVAPCO's **SPECTRUM™** Program. Please contact your local sales representative for more information on the **SPECTRUM™** program.

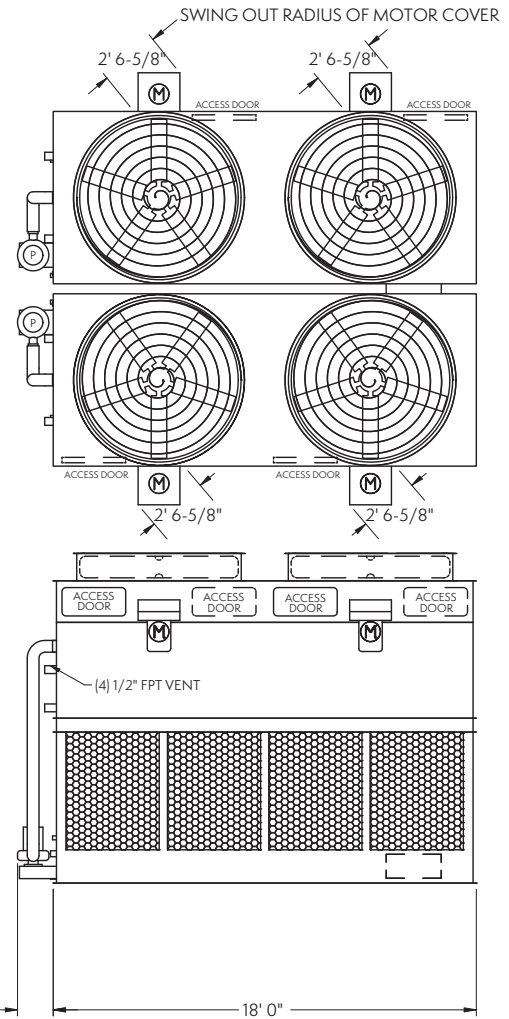
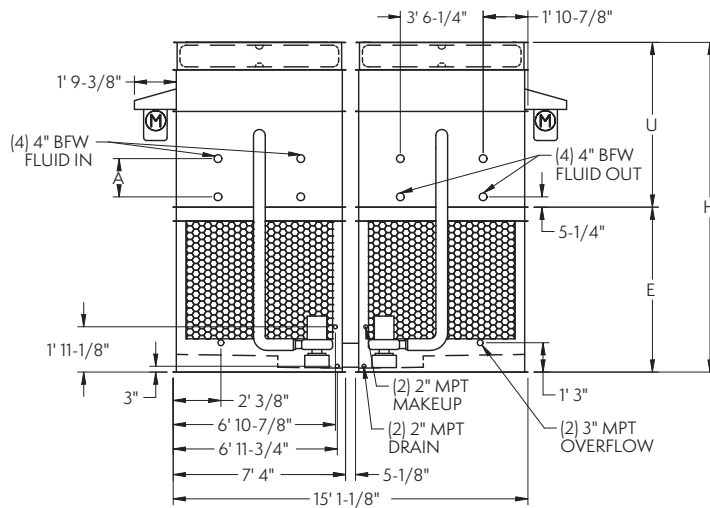

NOTE: The number of coil connections doubles when the flow rate exceeds 1,800 GPM on ATWB 14x18 models. This required option is referred to as the High Flow coil configuration.

ATWB Model Number†	Weights (lbs)			Fans		Spray Pump		Coil Volume (Gallons)	Remote Sump ▲			Dimensions ■			
	Shipping	Heaviest Section††	Operating	HP	CFM	HP	GPM		Gallons* Required	Conn. Size	Operating Weight (lbs)	Coil A	Upper U	Lower E	Height H
ATWB 14-3H18	27,940	10,950	38,520	(4) 7.5	136,960	(2) 5	800	558	480	(2) 12"	31,780	19-1/2"	7' 1/4"	7' 1/4"	14' 1/2"
ATWB 14-3I18	28,000	10,980	38,580	(4) 10	150,240	(2) 5	800	558	480	(2) 12"	31,840	19-1/2"	7' 1/4"	7' 1/4"	14' 1/2"
ATWB 14-4H18	32,140	13,050	44,200	(4) 7.5	132,970	(2) 5	800	736	480	(2) 12"	37,460	27"	7' 7-3/4"	7' 1/4"	14' 8"
ATWB 14-4I18	32,200	13,080	44,260	(4) 10	145,860	(2) 5	800	736	480	(2) 12"	37,520	27"	7' 7-3/4"	7' 1/4"	14' 8"
ATWB 14-4J18	32,700	13,330	44,760	(4) 15	163,400	(2) 5	800	736	480	(2) 12"	38,020	27"	7' 7-3/4"	7' 1/4"	14' 8"
ATWB 14-5H18	36,360	15,160	49,900	(4) 7.5	128,980	(2) 5	800	914	480	(2) 12"	43,160	34-1/2"	8' 3-1/4"	7' 1/4"	15' 3-1/2"
ATWB 14-5I18	36,420	15,190	49,960	(4) 10	141,490	(2) 5	800	914	480	(2) 12"	43,220	34-1/2"	8' 3-1/4"	7' 1/4"	15' 3-1/2"
ATWB 14-5J18	36,920	15,440	50,460	(4) 15	158,500	(2) 5	800	914	480	(2) 12"	43,720	34-1/2"	8' 3-1/4"	7' 1/4"	15' 3-1/2"
ATWB 14-6H18	40,700	17,330	55,740	(4) 7.5	124,990	(2) 5	800	1091	480	(2) 12"	49,000	42"	8' 10-3/4"	7' 1/4"	15' 11"
ATWB 14-6I18	40,760	17,360	55,800	(4) 10	137,110	(2) 5	800	1091	480	(2) 12"	49,060	42"	8' 10-3/4"	7' 1/4"	15' 11"
ATWB 14-6J18	41,260	17,610	56,300	(4) 15	153,600	(2) 5	800	1091	480	(2) 12"	49,560	42"	8' 10-3/4"	7' 1/4"	15' 11"
ATWB 14-7I18	45,080	19,520	61,600	(4) 10	132,740	(2) 5	800	1269	480	(2) 12"	54,860	47-3/4"	9' 4-1/2"	7' 1/4"	16' 4-3/4"
ATWB 14-7J18	45,580	19,770	62,100	(4) 15	148,700	(2) 5	800	1269	480	(2) 12"	55,360	47-3/4"	9' 4-1/2"	7' 1/4"	16' 4-3/4"

† Model Numbers end in "-Z" for units with Series Flow piping configuration. Series Flow units may require additional coil connections and will require crossover piping. Model numbers will include "C" for units with Stainless Steel coil(s), "R" for units with Low Sound Fan(s) and "S" for units with an option that negates CTI certification.

†† Heaviest section is the coil/fan section.

\* Gallons shown is water in suspension in unit and piping. Allow for additional water in bottom of remote sump to cover pump suction and strainer during operation (12" would normally be sufficient).

▲ When a remote sump arrangement is selected, the spray pump, suction strainer and associated piping are omitted; the unit is provided with an oversized outlet to facilitate drainage to the remote sump.

■ Unit dimensions and coil connections may vary slightly from catalog. See factory certified prints for dimensions, quantity of coil connections, and piping configuration. Coil connections are 4" bevel for weld (BFW). Other connection types such as grooved for mechanical coupling or flanged are also available as options.

# ATWB 9-3G8 to 9-7J8

Selections for ATWB Closed Circuit Coolers are available from EVAPCO's **SPECTRUM™** Program. Please contact your local sales representative for more information on the **SPECTRUM™** program.

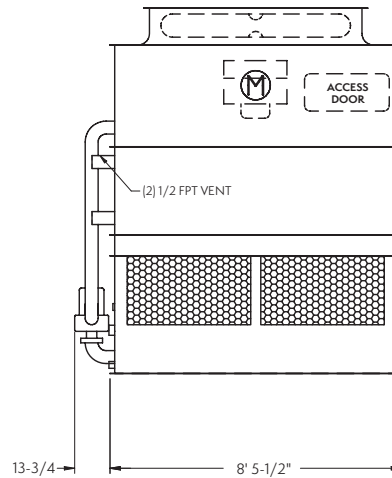
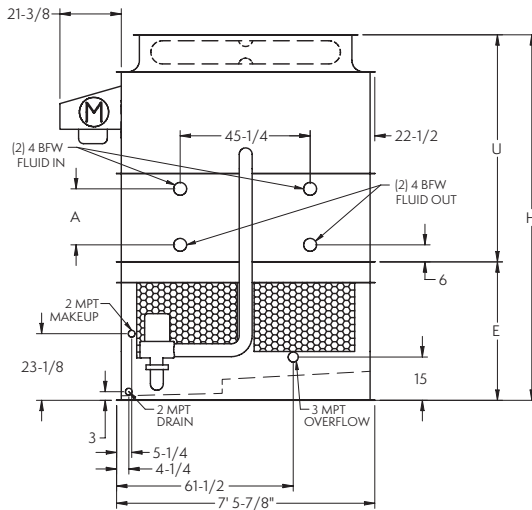
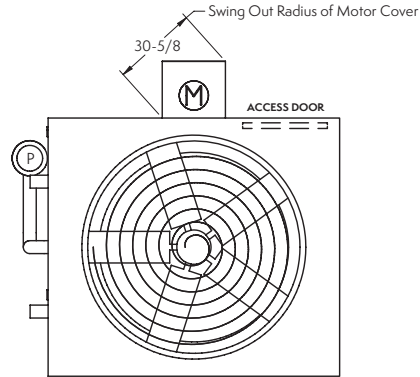

NOTE: The number of coil connections doubles when the flow rate exceeds 900 GPM on ATWB 9x8 models. This required option is referred to as the High Flow coil configuration.

ATWB Model Number†	Weights (lbs)			Fans		Spray Pump		Coil Volume (Gallons)	Remote Sump Δ			Dimensions ?			
	Shipping	Heaviest Section††	Operating	HP	CFM	HP	GPM		Gallons* Required	Conn. Size	Operating Weight (lbs)	Coil A	Upper U	Lower E	Height H
ATWB 9-3G8	6,770	5,470	10,190	5	29,190	2	340	143	220	8"	9,090	19-1/2"	6' 7"	4' 1/4"	10' 7-1/4"
ATWB 9-3H8	6,820	5,520	10,240	7.5	33,410	2	340	143	220	8"	9,140	19-1/2"	6' 7"	4' 1/4"	10' 7-1/4"
ATWB 9-3I8	6,830	5,530	10,250	10	36,580	2	340	143	220	8"	9,150	19-1/2"	6' 7"	4' 1/4"	10' 7-1/4"
ATWB 9-3J8	6,960	5,660	10,380	15	40,980	2	340	143	220	8"	9,280	19-1/2"	6' 7"	4' 1/4"	10' 7-1/4"
ATWB 9-4G8	7,730	6,430	11,510	5	28,340	2	340	187	220	8"	10,410	27"	7' 2-1/2"	4' 1/4"	11' 2-3/4"
ATWB 9-4H8	7,780	6,480	11,560	7.5	32,440	2	340	187	220	8"	10,460	27"	7' 2-1/2"	4' 1/4"	11' 2-3/4"
ATWB 9-4I8	7,790	6,490	11,570	10	35,520	2	340	187	220	8"	10,470	27"	7' 2-1/2"	4' 1/4"	11' 2-3/4"
ATWB 9-4J8	7,920	6,620	11,700	15	39,790	2	340	187	220	8"	10,600	27"	7' 2-1/2"	4' 1/4"	11' 2-3/4"
ATWB 9-5H8	8,820	7,520	12,970	7.5	31,470	2	340	230	220	8"	11,870	34-1/2"	7' 10"	4' 1/4"	11' 10-1/4"
ATWB 9-5I8	8,830	7,530	12,980	10	34,450	2	340	230	220	8"	11,880	34-1/2"	7' 10"	4' 1/4"	11' 10-1/4"
ATWB 9-5J8	8,960	7,660	13,110	15	38,590	2	340	230	220	8"	12,010	34-1/2"	7' 10"	4' 1/4"	11' 10-1/4"
ATWB 9-6H8	9,850	8,550	14,360	7.5	30,500	2	340	274	220	8"	13,260	42"	8' 5-1/2"	4' 1/4"	12' 5-3/4"
ATWB 9-6I8	9,860	8,560	14,370	10	33,390	2	340	274	220	8"	13,270	42"	8' 5-1/2"	4' 1/4"	12' 5-3/4"
ATWB 9-6J8	9,990	8,690	14,500	15	37,400	2	340	274	220	8"	13,400	42"	8' 5-1/2"	4' 1/4"	12' 5-3/4"
ATWB 9-7H8	10,960	9,660	15,840	7.5	29,520	2	340	318	220	8"	14,740	47-3/4"	8' 11-1/4"	4' 1/4"	12' 11-1/2"
ATWB 9-7I8	10,970	9,670	15,850	10	32,320	2	340	318	220	8"	14,750	47-3/4"	8' 11-1/4"	4' 1/4"	12' 11-1/2"
ATWB 9-7J8	11,100	9,800	15,980	15	36,210	2	340	318	220	8"	14,880	47-3/4"	8' 11-1/4"	4' 1/4"	12' 11-1/2"

† Model Numbers end in "-Z" for units with Series Flow piping configuration. Series Flow units may require additional coil connections and will require crossover piping. Model numbers will include "C" for units with Stainless Steel coil(s), "R" for units with Low Sound Fan(s) and "S" for units with an option that negates CTI certification.

†† Heaviest section is the coil/fan section.

\* Gallons shown is water in suspension in unit and piping. Allow for additional water in bottom of remote sump to cover pump suction and strainer during operation (12" would normally be sufficient).

Δ When a remote sump arrangement is selected, the spray pump, suction strainer and associated piping are omitted; the unit is provided with an oversized outlet to facilitate drainage to the remote sump.

■ Unit dimensions and coil connections may vary slightly from catalog. See factory certified prints for dimensions, quantity of coil connections, and piping configuration. Coil connections are 4" bevel for weld (BFW). Other connection types such as grooved for mechanical coupling or flanged are also available as options.

# ATWB 9-3H9 to 9-7K9

Selections for ATWB Closed Circuit Coolers are available from EVAPCO's **SPECTRUM™** Program. Please contact your local sales representative for more information on the **SPECTRUM™** program.

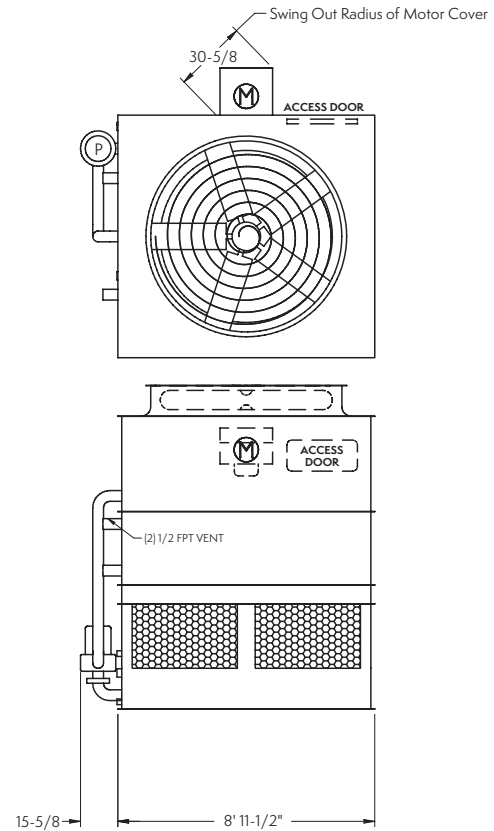
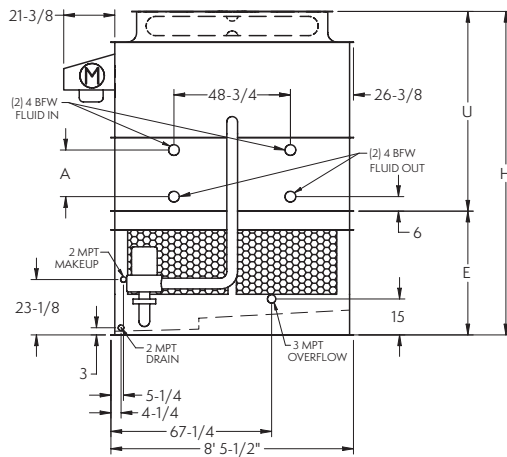

NOTE: The number of coil connections doubles when the flow rate exceeds 900 GPM on ATWB 9x9 models. This required option is referred to as the High Flow coil configuration.

ATWB Model Number†	Weights (lbs)			Fans		Spray Pump		Coil Volume (Gallons)	Remote Sump <sup>△</sup>			Dimensions <sup>■</sup>			
	Shipping	Heaviest Section††	Operating	HP	CFM	HP	GPM		Gallons* Required	Conn. Size	Operating Weight (lbs)	Coil A	Upper U	Lower E	Height H
ATWB 9-3H9	8,030	6,590	12,020	7.5	37,660	2	410	164	250	8"	10,740	19-1/2"	6' 11-1/2"	4' 3-7/8"	11' 3-3/8"
ATWB 9-3I9	8,040	6,600	12,030	10	41,440	2	410	164	250	8"	10,750	19-1/2"	6' 11-1/2"	4' 3-7/8"	11' 3-3/8"
ATWB 9-3J9	8,170	6,730	12,160	15	46,620	2	410	164	250	8"	10,880	19-1/2"	6' 11-1/2"	4' 3-7/8"	11' 3-3/8"
ATWB 9-3K9	8,230	6,790	12,220	20	50,540	2	410	164	250	8"	10,940	19-1/2"	6' 11-1/2"	4' 3-7/8"	11' 3-3/8"
ATWB 9-4H9	9,190	7,750	13,590	7.5	36,560	2	410	215	250	8"	12,310	27"	7' 7"	4' 3-7/8"	11' 10-7/8"
ATWB 9-4I9	9,200	7,760	13,600	10	40,240	2	410	215	250	8"	12,320	27"	7' 7"	4' 3-7/8"	11' 10-7/8"
ATWB 9-4J9	9,330	7,890	13,730	15	45,270	2	410	215	250	8"	12,450	27"	7' 7"	4' 3-7/8"	11' 10-7/8"
ATWB 9-4K9	9,390	7,950	13,790	20	49,060	2	410	215	250	8"	12,510	27"	7' 7"	4' 3-7/8"	11' 10-7/8"
ATWB 9-5H9	10,450	9,010	15,270	7.5	35,460	2	410	265	250	8"	13,990	34-1/2"	8' 2-1/2"	4' 3-7/8"	12' 6-3/8"
ATWB 9-5I9	10,460	9,020	15,280	10	39,030	2	410	265	250	8"	14,000	34-1/2"	8' 2-1/2"	4' 3-7/8"	12' 6-3/8"
ATWB 9-5J9	10,590	9,150	15,410	15	43,910	2	410	265	250	8"	14,130	34-1/2"	8' 2-1/2"	4' 3-7/8"	12' 6-3/8"
ATWB 9-5K9	10,650	9,210	15,470	20	47,590	2	410	265	250	8"	14,190	34-1/2"	8' 2-1/2"	4' 3-7/8"	12' 6-3/8"
ATWB 9-6I9	11,690	10,250	16,930	10	37,820	2	410	315	250	8"	15,650	42"	8' 10"	4' 3-7/8"	13' 1-7/8"
ATWB 9-6J9	11,820	10,380	17,060	15	42,550	2	410	315	250	8"	15,780	42"	8' 10"	4' 3-7/8"	13' 1-7/8"
ATWB 9-6K9	11,880	10,440	17,120	20	46,120	2	410	315	250	8"	15,840	42"	8' 10"	4' 3-7/8"	13' 1-7/8"
ATWB 9-7I9	13,200	11,760	18,860	10	36,620	2	410	365	250	8"	17,580	47-3/4"	9' 3-3/4"	4' 3-7/8"	13' 7-5/8"
ATWB 9-7J9	13,330	11,890	18,990	15	41,190	2	410	365	250	8"	17,710	47-3/4"	9' 3-3/4"	4' 3-7/8"	13' 7-5/8"
ATWB 9-7K9	13,390	11,950	19,050	20	44,650	2	410	365	250	8"	17,770	47-3/4"	9' 3-3/4"	4' 3-7/8"	13' 7-5/8"

† Model Numbers end in "-Z" for units with Series Flow piping configuration. Series Flow units may require additional coil connections and will require crossover piping. Model numbers will include "C" for units with Stainless Steel coil(s), "R" for units with Low Sound Fan(s) and "S" for units with an option that negates CTI certification.

†† Heaviest section is the coil/fan section.

\* Gallons shown is water in suspension in unit and piping. Allow for additional water in bottom of remote sump to cover pump suction and strainer during operation (12" would normally be sufficient).

△ When a remote sump arrangement is selected, the spray pump, suction strainer and associated piping are omitted; the unit is provided with an oversized outlet to facilitate drainage to the remote sump.

■ Unit dimensions and coil connections may vary slightly from catalog. See factory certified prints for dimensions, quantity of coil connections, and piping configuration. Coil connections are 4" bevel for weld (BFW). Other connection types such as grooved for mechanical coupling or flanged are also available as options.



# ATWB 9-3H11 to 9-7L11

Selections for ATWB Closed Circuit Coolers are available from EVAPCO's **SPECTRUM™** Program. Please contact your local sales representative for more information on the **SPECTRUM™** program.

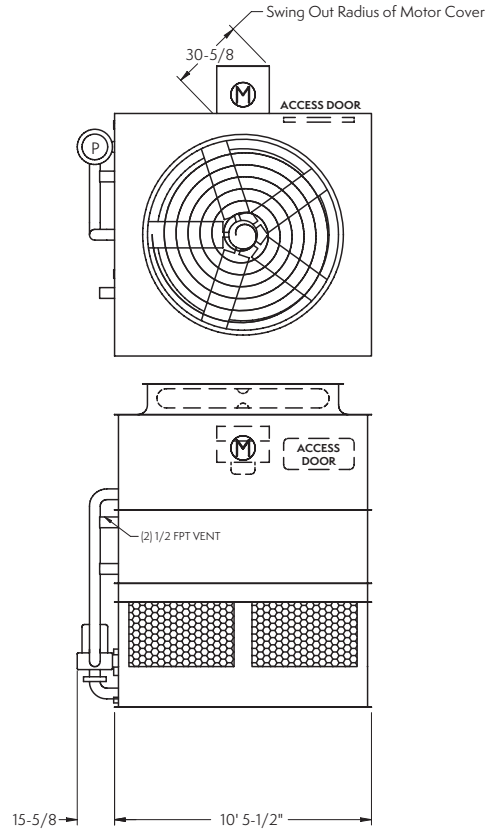
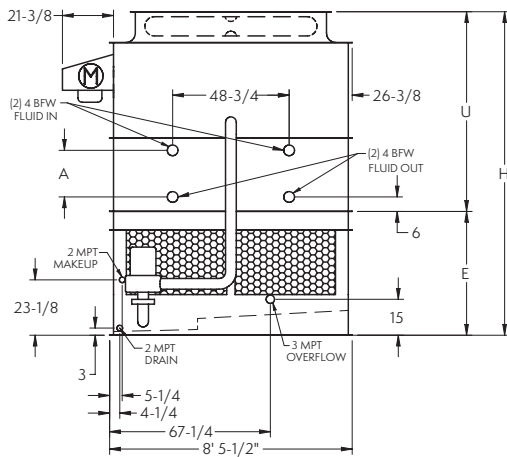

NOTE: The number of coil connections doubles when the flow rate exceeds 900 GPM on ATWB 9x11 models. This required option is referred to as the High Flow coil configuration.

ATWB Model Number†	Weights (lbs)			Fans		Spray Pump		Coil Volume (Gallons)	Remote Sump Δ			Dimensions ■			
	Shipping	Heaviest Section††	Operating	HP	CFM	HP	GPM		Gallons* Required	Conn. Size	Operating Weight (lbs)	Coil A	Upper U	Lower E	Height H
ATWB 9-3H11	9,230	7,590	13,910	7.5	41,750	3	500	190	290	10"	12,400	19-1/2"	6' 11-1/2"	4' 3-7/8"	11' 3-3/8"
ATWB 9-3I11	9,250	7,610	13,930	10	45,960	3	500	190	290	10"	12,420	19-1/2"	6' 11-1/2"	4' 3-7/8"	11' 3-3/8"
ATWB 9-3J11	9,370	7,730	14,050	15	52,130	3	500	190	290	10"	12,540	19-1/2"	6' 11-1/2"	4' 3-7/8"	11' 3-3/8"
ATWB 9-3K11	9,430	7,790	14,110	20	56,500	3	500	190	290	10"	12,600	19-1/2"	6' 11-1/2"	4' 3-7/8"	11' 3-3/8"
ATWB 9-4H11	10,580	8,940	15,750	7.5	40,540	3	500	249	290	10"	14,240	27"	7' 7"	4' 3-7/8"	11' 10-7/8"
ATWB 9-4I11	10,600	8,960	15,770	10	44,620	3	500	249	290	10"	14,260	27"	7' 7"	4' 3-7/8"	11' 10-7/8"
ATWB 9-4J11	10,720	9,080	15,890	15	50,610	3	500	249	290	10"	14,380	27"	7' 7"	4' 3-7/8"	11' 10-7/8"
ATWB 9-4K11	10,780	9,140	15,950	20	54,860	3	500	249	290	10"	14,440	27"	7' 7"	4' 3-7/8"	11' 10-7/8"
ATWB 9-5I11	12,090	10,450	17,750	10	43,280	3	500	307	290	10"	16,240	34-1/2"	8' 2-1/2"	4' 3-7/8"	12' 6-3/8"
ATWB 9-5J11	12,210	10,570	17,870	15	49,090	3	500	307	290	10"	16,360	34-1/2"	8' 2-1/2"	4' 3-7/8"	12' 6-3/8"
ATWB 9-5K11	12,270	10,630	17,930	20	53,210	3	500	307	290	10"	16,420	34-1/2"	8' 2-1/2"	4' 3-7/8"	12' 6-3/8"
ATWB 9-5L11	12,300	10,660	17,960	25	56,640	3	500	307	290	10"	16,450	34-1/2"	8' 2-1/2"	4' 3-7/8"	12' 6-3/8"
ATWB 9-6J11	13,640	12,000	19,790	15	47,570	3	500	366	290	10"	18,280	42"	8' 10"	4' 3-7/8"	13' 1-7/8"
ATWB 9-6K11	13,700	12,060	19,850	20	51,560	3	500	366	290	10"	18,340	42"	8' 10"	4' 3-7/8"	13' 1-7/8"
ATWB 9-6L11	13,730	12,090	19,880	25	54,890	3	500	366	290	10"	18,370	42"	8' 10"	4' 3-7/8"	13' 1-7/8"
ATWB 9-7J11	15,390	13,750	22,030	15	46,060	3	500	425	290	10"	20,520	47-3/4"	9' 3-3/4"	4' 3-7/8"	13' 7-5/8"
ATWB 9-7K11	15,450	13,810	22,090	20	49,920	3	500	425	290	10"	20,580	47-3/4"	9' 3-3/4"	4' 3-7/8"	13' 7-5/8"
ATWB 9-7L11	15,480	13,840	22,120	25	53,140	3	500	425	290	10"	20,610	47-3/4"	9' 3-3/4"	4' 3-7/8"	13' 7-5/8"

† Model Numbers end in "-Z" for units with Series Flow piping configuration. Series Flow units may require additional coil connections and will require crossover piping. Model numbers will include "C" for units with Stainless Steel coil(s), "R" for units with Low Sound Fan(s) and "S" for units with an option that negates CTI certification.

†† Heaviest section is the coil/fan section.

\* Gallons shown is water in suspension in unit and piping. Allow for additional water in bottom of remote sump to cover pump suction and strainer during operation (12" would normally be sufficient).

Δ When a remote sump arrangement is selected, the spray pump, suction strainer and associated piping are omitted; the unit is provided with an oversized outlet to facilitate drainage to the remote sump.

■ Unit dimensions and coil connections may vary slightly from catalog. See factory certified prints for dimensions, quantity of coil connections, and piping configuration. Coil connections are 4" bevel for weld (BFW). Other connection types such as grooved for mechanical coupling or flanged are also available as options.

# ATWB 9-3I12 to 9-7M12

Selections for ATWB Closed Circuit Coolers are available from EVAPCO's **SPECTRUM™** Program. Please contact your local sales representative for more information on the **SPECTRUM™** program.

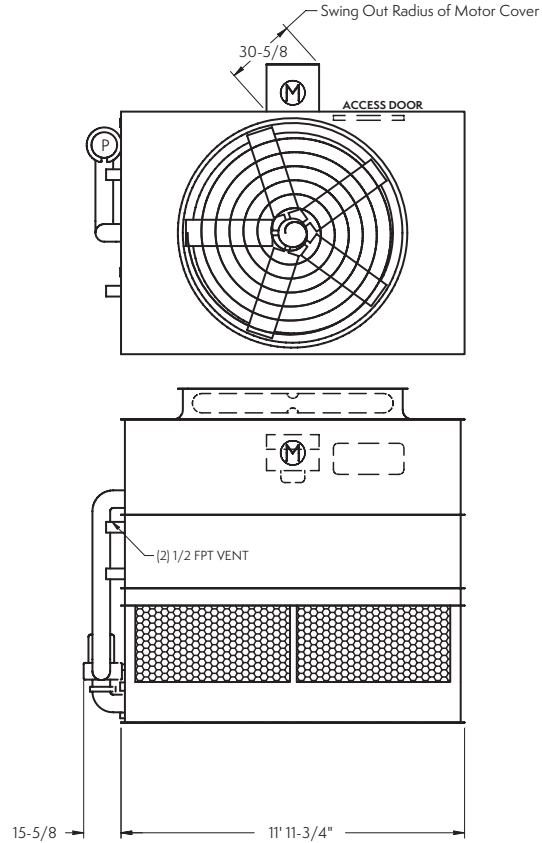
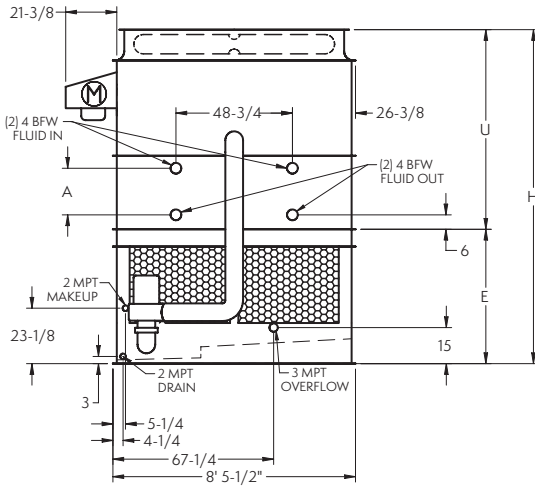

NOTE: The number of coil connections doubles when the flow rate exceeds 900 GPM on ATWB 9x12 models. This required option is referred to as the High Flow coil configuration.

ATWB Model Number†	Weights (lbs)			Fans		Spray Pump		Coil Volume (Gallons)	Remote Sump △			Dimensions ■			
	Shipping	Heaviest Section††	Operating	HP	CFM	HP	GPM		Gallons* Required	Conn. Size	Operating Weight (lbs)	Coil A	Upper U	Lower E	Height H
ATWB 9-3I12	9,940	8,140	15,380	10	50,310	3	550	216	330	10"	13,670	19-1/2"	6' 11-1/2"	4' 8-1/4"	11' 7-3/4"
ATWB 9-3J12	10,070	8,270	15,510	15	57,490	3	550	216	330	10"	13,800	19-1/2"	6' 11-1/2"	4' 8-1/4"	11' 7-3/4"
ATWB 9-3K12	10,130	8,330	15,570	20	62,310	3	550	216	330	10"	13,860	19-1/2"	6' 11-1/2"	4' 8-1/4"	11' 7-3/4"
ATWB 9-3L12	10,160	8,360	15,600	25	66,330	3	550	216	330	10"	13,890	19-1/2"	6' 11-1/2"	4' 8-1/4"	11' 7-3/4"
ATWB 9-4I12	11,520	9,720	17,520	10	48,850	3	550	283	330	10"	15,810	27"	7' 7"	4' 8-1/4"	12' 3-1/4"
ATWB 9-4J12	11,650	9,850	17,650	15	55,810	3	550	283	330	10"	15,940	27"	7' 7"	4' 8-1/4"	12' 3-1/4"
ATWB 9-4K12	11,710	9,910	17,710	20	60,490	3	550	283	330	10"	16,000	27"	7' 7"	4' 8-1/4"	12' 3-1/4"
ATWB 9-4L12	11,740	9,940	17,740	25	64,390	3	550	283	330	10"	16,030	27"	7' 7"	4' 8-1/4"	12' 3-1/4"
ATWB 9-5J12	13,230	11,430	19,790	15	54,140	3	550	350	330	10"	18,080	34-1/2"	8' 2-1/2"	4' 8-1/4"	12' 10-3/4"
ATWB 9-5K12	13,290	11,490	19,850	20	58,680	3	550	350	330	10"	18,140	34-1/2"	8' 2-1/2"	4' 8-1/4"	12' 10-3/4"
ATWB 9-5L12	13,320	11,520	19,880	25	62,460	3	550	350	330	10"	18,170	34-1/2"	8' 2-1/2"	4' 8-1/4"	12' 10-3/4"
ATWB 9-5M12	13,370	11,570	19,930	30	65,730	3	550	350	330	10"	18,220	34-1/2"	8' 2-1/2"	4' 8-1/4"	12' 10-3/4"
ATWB 9-6J12	14,870	13,070	21,990	15	52,460	3	550	418	330	10"	20,280	42"	8' 10"	4' 8-1/4"	13' 6-1/4"
ATWB 9-6K12	14,930	13,130	22,050	20	56,860	3	550	418	330	10"	20,340	42"	8' 10"	4' 8-1/4"	13' 6-1/4"
ATWB 9-6L12	14,960	13,160	22,080	25	60,530	3	550	418	330	10"	20,370	42"	8' 10"	4' 8-1/4"	13' 6-1/4"
ATWB 9-6M12	15,010	13,210	22,130	30	63,700	3	550	418	330	10"	20,420	42"	8' 10"	4' 8-1/4"	13' 6-1/4"
ATWB 9-7J12	16,800	15,000	24,480	15	50,790	3	550	485	330	10"	22,770	47-3/4"	9' 3-3/4"	4' 8-1/4"	14' 0"
ATWB 9-7K12	16,860	15,060	24,540	20	55,050	3	550	485	330	10"	22,830	47-3/4"	9' 3-3/4"	4' 8-1/4"	14' 0"
ATWB 9-7L12	16,890	15,090	24,570	25	58,600	3	550	485	330	10"	22,860	47-3/4"	9' 3-3/4"	4' 8-1/4"	14' 0"
ATWB 9-7M12	16,940	15,140	24,620	30	61,670	3	550	485	330	10"	22,910	47-3/4"	9' 3-3/4"	4' 8-1/4"	14' 0"

† Model Numbers end in "-Z" for units with Series Flow piping configuration. Series Flow units may require additional coil connections and will require crossover piping. Model numbers will include "C" for units with Stainless Steel coil(s), "R" for units with Low Sound Fan(s) and "S" for units with an option that negates CTI certification.

†† Heaviest section is the coil/fan section.

\* Gallons shown is water in suspension in unit and piping. Allow for additional water in bottom of remote sump to cover pump suction and strainer during operation (12" would normally be sufficient).

△ When a remote sump arrangement is selected, the spray pump, suction strainer and associated piping are omitted; the unit is provided with an oversized outlet to facilitate drainage to the remote sump.

■ Unit dimensions and coil connections may vary slightly from catalog. See factory certified prints for dimensions, quantity of coil connections, and piping configuration. Coil connections are 4" bevel for weld (BFW). Other connection types such as grooved for mechanical coupling or flanged are also available as options.

# ATWB 9-314 to 9-7M14

Selections for ATWB Closed Circuit Coolers are available from EVAPCO's **SPECTRUM™** Program. Please contact your local sales representative for more information on the **SPECTRUM™** program.

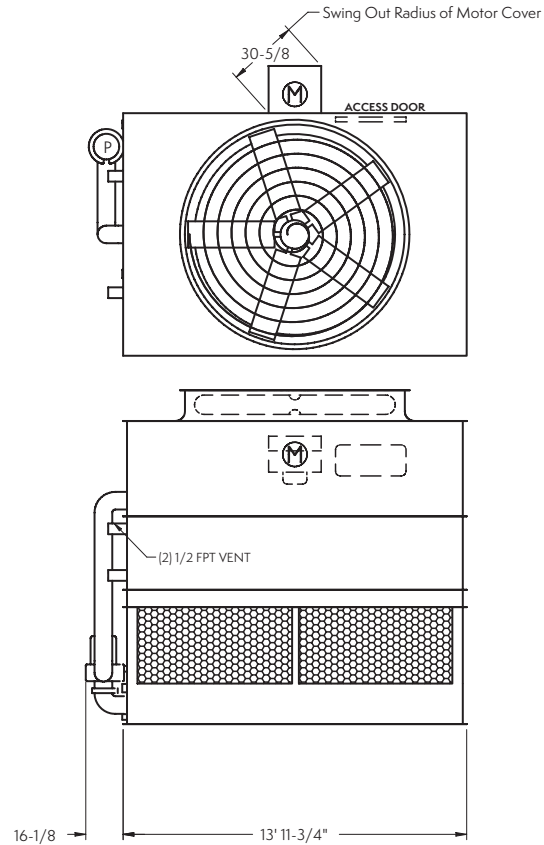
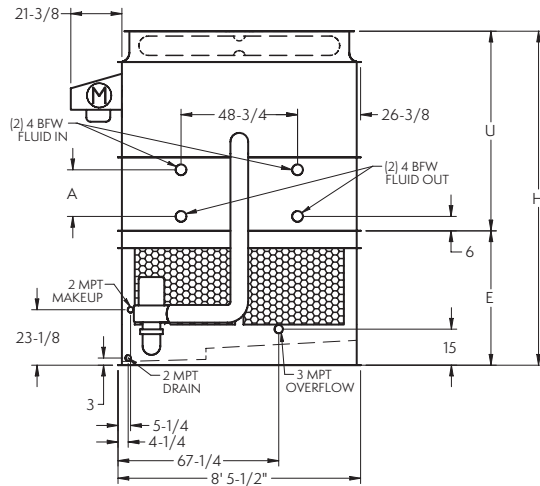

NOTE: The number of coil connections doubles when the flow rate exceeds 900 GPM on ATWB 9x14 models. This required option is referred to as the High Flow coil configuration.

ATWB Model Number†	Weights (lbs)			Fans		Spray Pump		Coil Volume (Gallons)	Remote Sump ▲			Dimensions ■			
	Shipping	Heaviest Section††	Operating	HP	CFM	HP	GPM		Gallons* Required	Conn. Size	Operating Weight (lbs)	Coil A	Upper U	Lower E	Height H
ATWB 9-314	11,240	9,230	17,550	10	55,780	3	600	250	380	10"	15,590	19-1/2"	6' 11-1/2"	4' 8-1/4"	11' 7-3/4"
ATWB 9-3J14	11,370	9,360	17,680	15	63,850	3	600	250	380	10"	15,720	19-1/2"	6' 11-1/2"	4' 8-1/4"	11' 7-3/4"
ATWB 9-3K14	11,430	9,420	17,740	20	69,640	3	600	250	380	10"	15,780	19-1/2"	6' 11-1/2"	4' 8-1/4"	11' 7-3/4"
ATWB 9-3L14	11,460	9,450	17,770	25	74,130	3	600	250	380	10"	15,810	19-1/2"	6' 11-1/2"	4' 8-1/4"	11' 7-3/4"
ATWB 9-4J14	13,190	11,180	20,160	15	61,990	3	600	329	380	10"	18,200	27"	7' 7"	4' 8-1/4"	12' 3-1/4"
ATWB 9-4K14	13,250	11,240	20,220	20	67,620	3	600	329	380	10"	18,260	27"	7' 7"	4' 8-1/4"	12' 3-1/4"
ATWB 9-4L14	13,280	11,270	20,250	25	71,970	3	600	329	380	10"	18,290	27"	7' 7"	4' 8-1/4"	12' 3-1/4"
ATWB 9-4M14	13,330	11,320	20,300	30	75,740	3	600	329	380	10"	18,340	27"	7' 7"	4' 8-1/4"	12' 3-1/4"
ATWB 9-5J14	15,030	13,020	22,650	15	60,130	3	600	407	380	10"	20,690	34-1/2"	8' 2-1/2"	4' 8-1/4"	12' 10-3/4"
ATWB 9-5K14	15,090	13,080	22,710	20	65,590	3	600	407	380	10"	20,750	34-1/2"	8' 2-1/2"	4' 8-1/4"	12' 10-3/4"
ATWB 9-5L14	15,120	13,110	22,740	25	69,820	3	600	407	380	10"	20,780	34-1/2"	8' 2-1/2"	4' 8-1/4"	12' 10-3/4"
ATWB 9-5M14	15,170	13,160	22,790	30	73,470	3	600	407	380	10"	20,830	34-1/2"	8' 2-1/2"	4' 8-1/4"	12' 10-3/4"
ATWB 9-6K14	16,990	14,980	25,270	20	63,560	3	600	486	380	10"	23,310	42"	8' 10"	4' 8-1/4"	13' 6-1/4"
ATWB 9-6L14	17,020	15,010	25,300	25	67,660	3	600	486	380	10"	23,340	42"	8' 10"	4' 8-1/4"	13' 6-1/4"
ATWB 9-6M14	17,070	15,060	25,350	30	71,200	3	600	486	380	10"	23,390	42"	8' 10"	4' 8-1/4"	13' 6-1/4"
ATWB 9-7K14	19,250	17,240	28,190	20	61,530	3	600	565	380	10"	26,230	47-3/4"	9' 3-3/4"	4' 8-1/4"	14' 0"
ATWB 9-7L14	19,280	17,270	28,220	25	65,500	3	600	565	380	10"	26,260	47-3/4"	9' 3-3/4"	4' 8-1/4"	14' 0"
ATWB 9-7M14	19,330	17,320	28,270	30	68,930	3	600	565	380	10"	26,310	47-3/4"	9' 3-3/4"	4' 8-1/4"	14' 0"

† Model Numbers end in "-Z" for units with Series Flow piping configuration. Series Flow units may require additional coil connections and will require crossover piping. Model numbers will include "C" for units with Stainless Steel coil(s), "R" for units with Low Sound Fan(s) and "S" for units with an option that negates CTI certification.

†† Heaviest section is the coil/fan section.

\* Gallons shown is water in suspension in unit and piping. Allow for additional water in bottom of remote sump to cover pump suction and strainer during operation (12" would normally be sufficient).

▲ When a remote sump arrangement is selected, the spray pump, suction strainer and associated piping are omitted; the unit is provided with an oversized outlet to facilitate drainage to the remote sump.

■ Unit dimensions and coil connections may vary slightly from catalog. See factory certified prints for dimensions, quantity of coil connections, and piping configuration. Coil connections are 4" bevel for weld (BFW). Other connection types such as grooved for mechanical coupling or flanged are also available as options.

# ATWB 9-3-H18 to 9-7K18

Selections for ATWB Closed Circuit Coolers are available from EVAPCO's **SPECTRUM™** Program. Please contact your local sales representative for more information on the **SPECTRUM™** program.

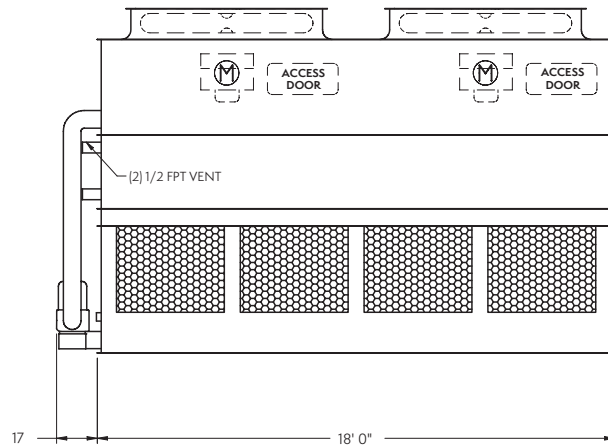
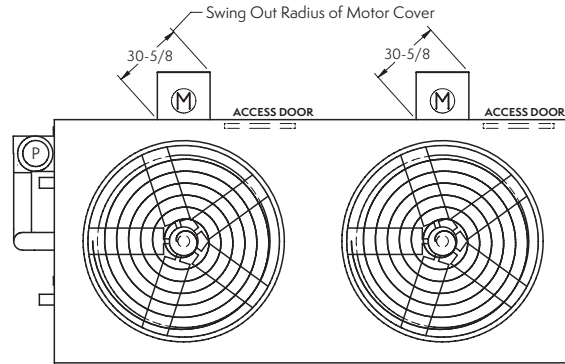
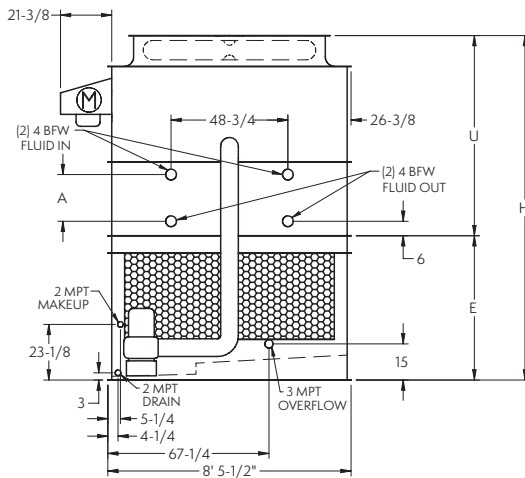

NOTE: The number of coil connections doubles when the flow rate exceeds 900 GPM on ATWB 9x18 models. This required option is referred to as the High Flow coil configuration.

ATWB Model Number†	Weights (lbs)			Fans		Spray Pump		Coil Volume (Gallons)	Remote Sump ▲			Dimensions ■			
	Shipping	Heaviest Section††	Operating	HP	CFM	HP	GPM		Gallons* Required	Conn. Size	Operating Weight (lbs)	Coil A	Upper U	Lower E	Height H
ATWB 9-3H18	15,200	12,410	23,370	(2) 7.5	75,570	5	800	319	510	12"	20,820	19 1/2"	6' 11-1/2"	5' 1/4"	11' 11-3/4"
ATWB 9-3I18	15,230	12,440	23,400	(2) 10	83,180	5	800	319	510	12"	20,850	19 1/2"	6' 11-1/2"	5' 1/4"	11' 11-3/4"
ATWB 9-3J18	15,480	12,690	23,650	(2) 15	93,600	5	800	319	510	12"	21,100	19 1/2"	6' 11-1/2"	5' 1/4"	11' 11-3/4"
ATWB 9-3K18	15,600	12,810	23,770	(2) 20	101,450	5	800	319	510	12"	21,220	19 1/2"	6' 11-1/2"	5' 1/4"	11' 11-3/4"
ATWB 9-4H18	17,600	14,810	26,610	(2) 7.5	73,370	5	800	420	510	12"	24,060	27"	7' 7"	5' 1/4"	12' 7-1/4"
ATWB 9-4I18	17,630	14,840	26,640	(2) 10	80,760	5	800	420	510	12"	24,090	27"	7' 7"	5' 1/4"	12' 7-1/4"
ATWB 9-4J18	17,880	15,090	26,890	(2) 15	90,880	5	800	420	510	12"	24,340	27"	7' 7"	5' 1/4"	12' 7-1/4"
ATWB 9-4K18	18,000	15,210	27,010	(2) 20	98,500	5	800	420	510	12"	24,460	27"	7' 7"	5' 1/4"	12' 7-1/4"
ATWB 9-5H18	19,920	17,130	29,780	(2) 7.5	71,170	5	800	522	510	12"	27,230	34 1/2"	8' 2-1/2"	5' 1/4"	13' 2-3/4"
ATWB 9-5I18	19,950	17,160	29,810	(2) 10	78,330	5	800	522	510	12"	27,260	34 1/2"	8' 2-1/2"	5' 1/4"	13' 2-3/4"
ATWB 9-5J18	20,200	17,410	30,060	(2) 15	88,150	5	800	522	510	12"	27,510	34 1/2"	8' 2-1/2"	5' 1/4"	13' 2-3/4"
ATWB 9-5K18	20,320	17,530	30,180	(2) 20	95,540	5	800	522	510	12"	27,630	34 1/2"	8' 2-1/2"	5' 1/4"	13' 2-3/4"
ATWB 9-6I18	22,410	19,620	33,120	(2) 10	75,910	5	800	623	510	12"	30,570	42"	8' 10"	5' 1/4"	13' 10-1/4"
ATWB 9-6J18	22,660	19,870	33,370	(2) 15	85,420	5	800	623	510	12"	30,820	42"	8' 10"	5' 1/4"	13' 10-1/4"
ATWB 9-6K18	22,780	19,990	33,490	(2) 20	92,590	5	800	623	510	12"	30,940	42"	8' 10"	5' 1/4"	13' 10-1/4"
ATWB 9-7I18	25,280	22,490	36,830	(2) 10	73,490	5	800	725	510	12"	34,280	47 3/4"	9' 3-3/4"	5' 1/4"	14' 4"
ATWB 9-7J18	25,530	22,740	37,080	(2) 15	82,700	5	800	725	510	12"	34,530	47 3/4"	9' 3-3/4"	5' 1/4"	14' 4"
ATWB 9-7K18	25,650	22,860	37,200	(2) 20	89,630	5	800	725	510	12"	34,650	47 3/4"	9' 3-3/4"	5' 1/4"	14' 4"

† Model Numbers end in "-Z" for units with Series Flow piping configuration. Series Flow units may require additional coil connections and will require crossover piping. Model numbers will include "C" for units with Stainless Steel coil(s), "R" for units with Low Sound Fan(s) and "S" for units with an option that negates CTI certification.

†† Heaviest section is the coil/fan section.

\* Gallons shown is water in suspension in unit and piping. Allow for additional water in bottom of remote sump to cover pump suction and strainer during operation (12" would normally be sufficient).

▲ When a remote sump arrangement is selected, the spray pump, suction strainer and associated piping are omitted; the unit is provided with an oversized outlet to facilitate drainage to the remote sump.

■ Unit dimensions and coil connections may vary slightly from catalog. See factory certified prints for dimensions, quantity of coil connections, and piping configuration. Coil connections are 4" bevel for weld (BFW). Other connection types such as grooved for mechanical coupling or flanged are also available as options.



# ATWB 9-3H21 to 9-7L21

Selections for ATWB Closed Circuit Coolers are available from EVAPCO's **SPECTRUM™** Program. Please contact your local sales representative for more information on the **SPECTRUM™** program.

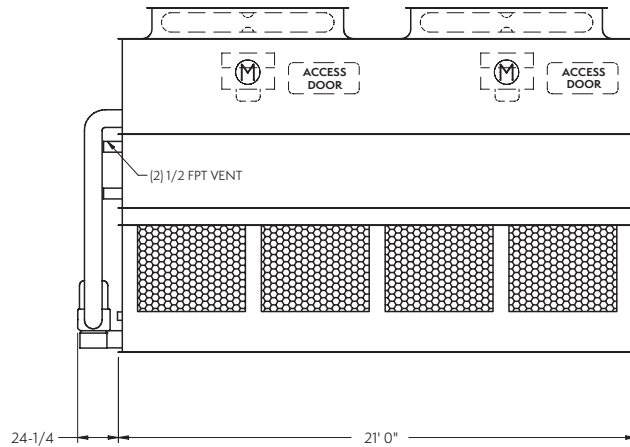
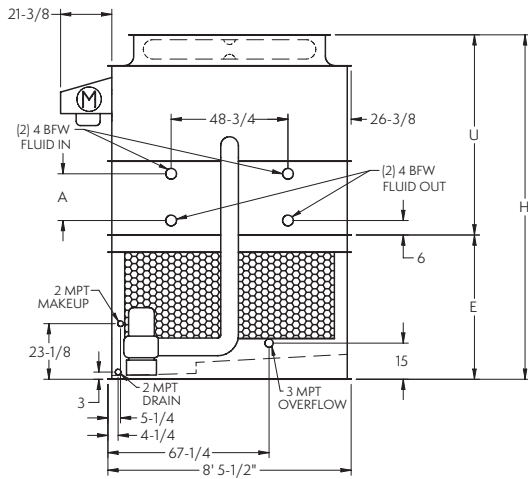
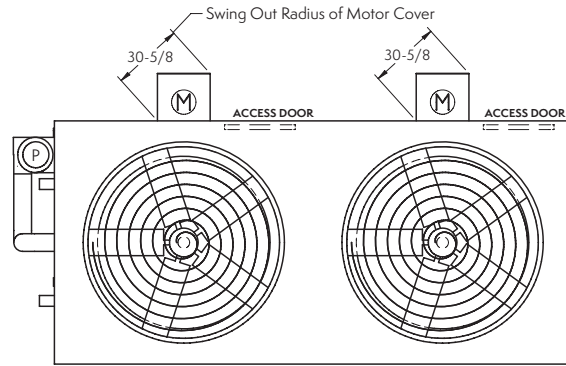

NOTE: The number of coil connections doubles when the flow rate exceeds 900 GPM on ATWB 9x21 models. This required option is referred to as the High Flow coil configuration.

ATWB Model Number†	Weights (lbs)			Fans		Spray Pump		Coil Volume (Gallons)	Remote Sump ▲			Dimensions ■			
	Shipping	Heaviest Section††	Operating	HP	CFM	HP	GPM		Gallons* Required	Conn. Size	Operating Weight (lbs)	Coil A	Upper U	Lower E	Height H
ATWB 9-3H21	17,260	14,160	26,870	(2) 7.5	83,760	7.5	1,050	370	590	12"	23,900	19-1/2"	6' 11-1/2"	5' 1/4"	11' 11-3/4"
ATWB 9-3I21	17,290	14,190	26,900	(2) 10	92,190	7.5	1,050	370	590	12"	23,930	19-1/2"	6' 11-1/2"	5' 1/4"	11' 11-3/4"
ATWB 9-3J21	17,540	14,440	27,150	(2) 15	104,590	7.5	1,050	370	590	12"	24,180	19-1/2"	6' 11-1/2"	5' 1/4"	11' 11-3/4"
ATWB 9-3K21	17,660	14,560	27,270	(2) 20	113,370	7.5	1,050	370	590	12"	24,300	19-1/2"	6' 11-1/2"	5' 1/4"	11' 11-3/4"
ATWB 9-4H21	20,040	16,940	30,640	(2) 7.5	81,320	7.5	1,050	489	590	12"	27,670	27"	7' 7"	5' 1/4"	12' 7-1/4"
ATWB 9-4I21	20,070	16,970	30,670	(2) 10	89,500	7.5	1,050	489	590	12"	27,700	27"	7' 7"	5' 1/4"	12' 7-1/4"
ATWB 9-4J21	20,320	17,220	30,920	(2) 15	101,550	7.5	1,050	489	590	12"	27,950	27"	7' 7"	5' 1/4"	12' 7-1/4"
ATWB 9-4K21	20,440	17,340	31,040	(2) 20	110,070	7.5	1,050	489	590	12"	28,070	27"	7' 7"	5' 1/4"	12' 7-1/4"
ATWB 9-5I21	22,780	19,680	34,370	(2) 10	86,820	7.5	1,050	608	590	12"	31,400	34-1/2"	8' 2-1/2"	5' 1/4"	13' 2-3/4"
ATWB 9-5J21	23,030	19,930	34,620	(2) 15	98,500	7.5	1,050	608	590	12"	31,650	34-1/2"	8' 2-1/2"	5' 1/4"	13' 2-3/4"
ATWB 9-5K21	23,150	20,050	34,740	(2) 20	106,760	7.5	1,050	608	590	12"	31,770	34-1/2"	8' 2-1/2"	5' 1/4"	13' 2-3/4"
ATWB 9-5L21	23,210	20,110	34,800	(2) 25	113,650	7.5	1,050	608	590	12"	31,830	34-1/2"	8' 2-1/2"	5' 1/4"	13' 2-3/4"
ATWB 9-6J21	25,880	22,780	38,460	(2) 15	95,460	7.5	1,050	726	590	12"	35,490	42"	8' 10"	5' 1/4"	13' 10-1/4"
ATWB 9-6K21	26,000	22,900	38,580	(2) 20	103,460	7.5	1,050	726	590	12"	35,610	42"	8' 10"	5' 1/4"	13' 10-1/4"
ATWB 9-6L21	26,060	22,960	38,640	(2) 25	110,130	7.5	1,050	726	590	12"	35,670	42"	8' 10"	5' 1/4"	13' 10-1/4"
ATWB 9-7J21	29,210	26,110	42,780	(2) 15	92,410	7.5	1,050	845	590	12"	39,810	47-3/4"	9' 3-3/4"	5' 1/4"	14' 4"
ATWB 9-7K21	29,330	26,230	42,900	(2) 20	100,160	7.5	1,050	845	590	12"	39,930	47-3/4"	9' 3-3/4"	5' 1/4"	14' 4"
ATWB 9-7L21	29,390	26,290	42,960	(2) 25	106,620	7.5	1,050	845	590	12"	39,990	47-3/4"	9' 3-3/4"	5' 1/4"	14' 4"

† Model Numbers end in "-Z" for units with Series Flow piping configuration. Series Flow units may require additional coil connections and will require crossover piping. Model numbers will include "C" for units with Stainless Steel coil(s), "R" for units with Low Sound Fan(s) and "S" for units with an option that negates CTI certification.

†† Heaviest section is the coil/fan section.

\* Gallons shown is water in suspension in unit and piping. Allow for additional water in bottom of remote sump to cover pump suction and strainer during operation (12" would normally be sufficient).

▲ When a remote sump arrangement is selected, the spray pump, suction strainer and associated piping are omitted; the unit is provided with an oversized outlet to facilitate drainage to the remote sump.

■ Unit dimensions and coil connections may vary slightly from catalog. See factory certified prints for dimensions, quantity of coil connections, and piping configuration. Coil connections are 4" bevel for weld (BFW). Other connection types such as grooved for mechanical coupling or flanged are also available as options.

# ATWB 17-3I12 to 17-7M12

Selections for ATWB Closed Circuit Coolers are available from EVAPCO's **SPECTRUM™** Program. Please contact your local sales representative for more information on the **SPECTRUM™** program.

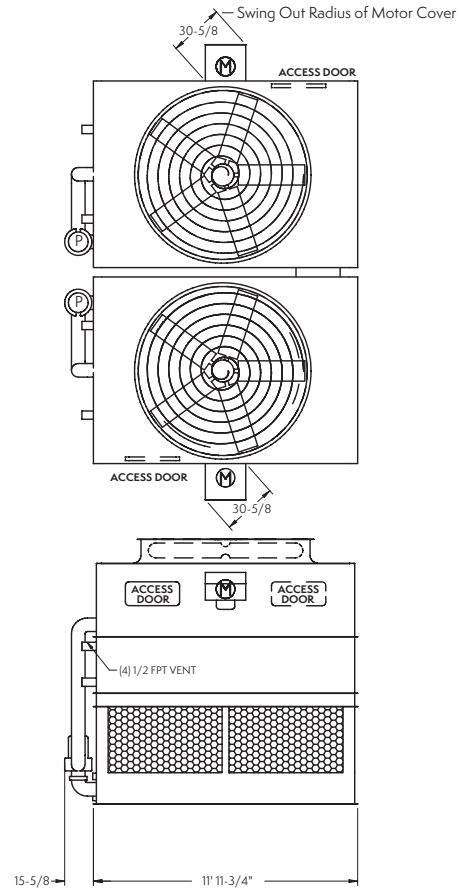
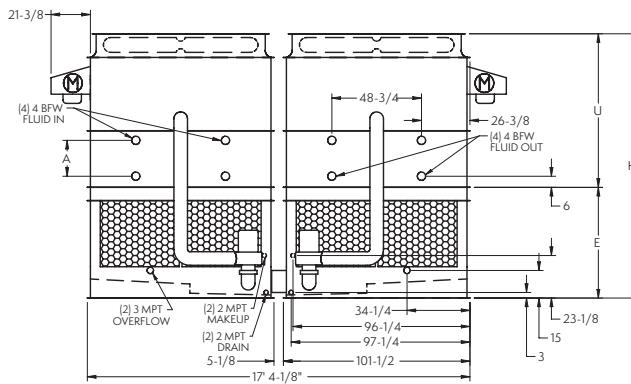

NOTE: The number of coil connections doubles when the flow rate exceeds 1,800 GPM on ATWB 17x12 models. This required option is referred to as the High Flow coil configuration.

ATWB Model Number†	Weights (lbs)			Fans		Spray Pump		Coil Volume (Gallons)	Remote Sump △			Dimensions ■			
	Shipping	Heaviest Section††	Operating	HP	CFM	HP	GPM		Gallons* Required	Conn. Size	Operating Weight (lbs)	Coil A	Upper U	Lower E	Height H
ATWB 17-3I12	19,880	8,140	30,760	(2) 10	100,630	(2) 3	1,100	432	660	(2) 10"	27,340	19-1/2"	6' 11-1/2"	5' 1/4"	11' 11-3/4"
ATWB 17-3J12	20,140	8,270	31,020	(2) 15	114,970	(2) 3	1,100	432	660	(2) 10"	27,600	19-1/2"	6' 11-1/2"	5' 1/4"	11' 11-3/4"
ATWB 17-3K12	20,260	8,330	31,140	(2) 20	124,620	(2) 3	1,100	432	660	(2) 10"	27,720	19-1/2"	6' 11-1/2"	5' 1/4"	11' 11-3/4"
ATWB 17-3L12	20,320	8,360	31,200	(2) 25	132,650	(2) 3	1,100	432	660	(2) 10"	27,780	19-1/2"	6' 11-1/2"	5' 1/4"	11' 11-3/4"
ATWB 17-4I12	23,040	9,720	35,040	(2) 10	97,700	(2) 3	1,100	566	660	(2) 10"	31,620	27"	7' 7"	5' 1/4"	12' 7-1/4"
ATWB 17-4J12	23,300	9,850	35,300	(2) 15	111,620	(2) 3	1,100	566	660	(2) 10"	31,880	27"	7' 7"	5' 1/4"	12' 7-1/4"
ATWB 17-4K12	23,420	9,910	35,420	(2) 20	120,990	(2) 3	1,100	566	660	(2) 10"	32,000	27"	7' 7"	5' 1/4"	12' 7-1/4"
ATWB 17-4L12	23,480	9,940	35,480	(2) 25	128,790	(2) 3	1,100	566	660	(2) 10"	32,060	27"	7' 7"	5' 1/4"	12' 7-1/4"
ATWB 17-5J12	26,460	11,430	39,580	(2) 15	108,280	(2) 3	1,100	701	660	(2) 10"	36,160	34-1/2"	8' 2-1/2"	5' 1/4"	13' 2-3/4"
ATWB 17-5K12	26,580	11,490	39,700	(2) 20	117,360	(2) 3	1,100	701	660	(2) 10"	36,280	34-1/2"	8' 2-1/2"	5' 1/4"	13' 2-3/4"
ATWB 17-5L12	26,640	11,520	39,760	(2) 25	124,920	(2) 3	1,100	701	660	(2) 10"	36,340	34-1/2"	8' 2-1/2"	5' 1/4"	13' 2-3/4"
ATWB 17-5M12	26,740	11,570	39,860	(2) 30	131,470	(2) 3	1,100	701	660	(2) 10"	36,440	34-1/2"	8' 2-1/2"	5' 1/4"	13' 2-3/4"
ATWB 17-6J12	29,740	13,070	43,980	(2) 15	104,930	(2) 3	1,100	835	660	(2) 10"	40,560	42"	8' 10"	5' 1/4"	13' 10-1/4"
ATWB 17-6K12	29,860	13,130	44,100	(2) 20	113,730	(2) 3	1,100	835	660	(2) 10"	40,680	42"	8' 10"	5' 1/4"	13' 10-1/4"
ATWB 17-6L12	29,920	13,160	44,160	(2) 25	121,060	(2) 3	1,100	835	660	(2) 10"	40,740	42"	8' 10"	5' 1/4"	13' 10-1/4"
ATWB 17-6M12	30,020	13,210	44,260	(2) 30	127,400	(2) 3	1,100	835	660	(2) 10"	40,840	42"	8' 10"	5' 1/4"	13' 10-1/4"
ATWB 17-7J12	33,600	15,000	48,960	(2) 15	101,580	(2) 3	1,100	969	660	(2) 10"	45,540	47-3/4"	9' 3-3/4"	5' 1/4"	14' 4"
ATWB 17-7K12	33,720	15,060	49,080	(2) 20	110,100	(2) 3	1,100	969	660	(2) 10"	45,660	47-3/4"	9' 3-3/4"	5' 1/4"	14' 4"
ATWB 17-7L12	33,780	15,090	49,140	(2) 25	117,200	(2) 3	1,100	969	660	(2) 10"	45,720	47-3/4"	9' 3-3/4"	5' 1/4"	14' 4"
ATWB 17-7M12	33,880	15,140	49,240	(2) 30	123,340	(2) 3	1,100	969	660	(2) 10"	45,820	47-3/4"	9' 3-3/4"	5' 1/4"	14' 4"

† Model Numbers end in "-Z" for units with Series Flow piping configuration. Series Flow units may require additional coil connections and will require crossover piping. Model numbers will include "C" for units with Stainless Steel coil(s), "R" for units with Low Sound Fan(s) and "S" for units with an option that negates CTI certification.

†† Heaviest section is the coil/fan section.

\* Gallons shown is water in suspension in unit and piping. Allow for additional water in bottom of remote sump to cover pump suction and strainer during operation (12" would normally be sufficient).

△ When a remote sump arrangement is selected, the spray pump, suction strainer and associated piping are omitted; the unit is provided with an oversized outlet to facilitate drainage to the remote sump.

■ Unit dimensions and coil connections may vary slightly from catalog. See factory certified prints for dimensions, quantity of coil connections, and piping configuration. Coil connections are 4" bevel for weld (BFW). Other connection types such as grooved for mechanical coupling or flanged are also available as options.

# ATWB 17-3I14 to 17-7M14

Selections for ATWB Closed Circuit Coolers are available from EVAPCO's **SPECTRUM™** Program. Please contact your local sales representative for more information on the **SPECTRUM™** program.

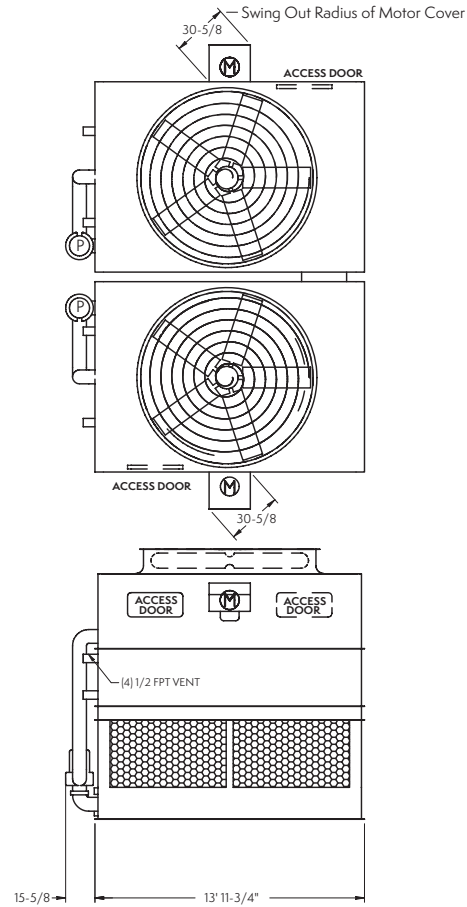
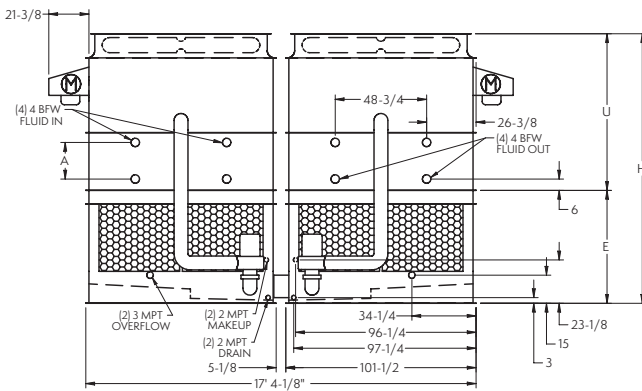

NOTE: The number of coil connections doubles when the flow rate exceeds 1,800 GPM on ATWB 17x14 models. This required option is referred to as the High Flow coil configuration.

ATWB Model Number†	Weights (lbs)			Fans		Spray Pump		Coil Volume (Gallons)	Remote Sump ▲			Dimensions ■			
	Shipping	Heaviest Section††	Operating	HP	CFM	HP	GPM		Gallons* Required	Conn. Size	Operating Weight (lbs)	Coil A	Upper U	Lower E	Height H
ATWB 17-3I14	22,480	9,230	35,100	[2] 10	111,550	[2] 3	1,200	500	760	[2] 10"	31,180	19-1/2"	6' 11-1/2"	5' 6-1/4"	12' 5-3/4"
ATWB 17-3J14	22,740	9,360	35,360	[2] 15	127,690	[2] 3	1,200	500	760	[2] 10"	31,440	19-1/2"	6' 11-1/2"	5' 6-1/4"	12' 5-3/4"
ATWB 17-3K14	22,860	9,420	35,480	[2] 20	139,290	[2] 3	1,200	500	760	[2] 10"	31,560	19-1/2"	6' 11-1/2"	5' 6-1/4"	12' 5-3/4"
ATWB 17-3L14	22,920	9,450	35,540	[2] 25	148,270	[2] 3	1,200	500	760	[2] 10"	31,620	19-1/2"	6' 11-1/2"	5' 6-1/4"	12' 5-3/4"
ATWB 17-4J14	26,380	11,180	40,320	[2] 15	123,970	[2] 3	1,200	658	760	[2] 10"	36,400	27"	7' 7"	5' 6-1/4"	13' 1-1/4"
ATWB 17-4K14	26,500	11,240	40,440	[2] 20	135,230	[2] 3	1,200	658	760	[2] 10"	36,520	27"	7' 7"	5' 6-1/4"	13' 1-1/4"
ATWB 17-4L14	26,560	11,270	40,500	[2] 25	143,950	[2] 3	1,200	658	760	[2] 10"	36,580	27"	7' 7"	5' 6-1/4"	13' 1-1/4"
ATWB 17-4M14	26,660	11,320	40,600	[2] 30	151,490	[2] 3	1,200	658	760	[2] 10"	36,680	27"	7' 7"	5' 6-1/4"	13' 1-1/4"
ATWB 17-5J14	30,060	13,020	45,300	[2] 15	120,250	[2] 3	1,200	815	760	[2] 10"	41,380	34-1/2"	8' 2-1/2"	5' 6-1/4"	13' 8-3/4"
ATWB 17-5K14	30,180	13,080	45,420	[2] 20	131,170	[2] 3	1,200	815	760	[2] 10"	41,500	34-1/2"	8' 2-1/2"	5' 6-1/4"	13' 8-3/4"
ATWB 17-5L14	30,240	13,110	45,480	[2] 25	139,630	[2] 3	1,200	815	760	[2] 10"	41,560	34-1/2"	8' 2-1/2"	5' 6-1/4"	13' 8-3/4"
ATWB 17-5M14	30,340	13,160	45,580	[2] 30	146,940	[2] 3	1,200	815	760	[2] 10"	41,660	34-1/2"	8' 2-1/2"	5' 6-1/4"	13' 8-3/4"
ATWB 17-6K14	33,980	14,980	50,540	[2] 20	127,120	[2] 3	1,200	972	760	[2] 10"	46,620	42"	8' 10"	5' 6-1/4"	14' 4-1/4"
ATWB 17-6L14	34,040	15,010	50,600	[2] 25	135,310	[2] 3	1,200	972	760	[2] 10"	46,680	42"	8' 10"	5' 6-1/4"	14' 4-1/4"
ATWB 17-6M14	34,140	15,060	50,700	[2] 30	142,400	[2] 3	1,200	972	760	[2] 10"	46,780	42"	8' 10"	5' 6-1/4"	14' 4-1/4"
ATWB 17-7K14	38,500	17,240	56,380	[2] 20	123,060	[2] 3	1,200	1,129	760	[2] 10"	52,460	47-3/4"	9' 3-3/4"	5' 6-1/4"	14' 10"
ATWB 17-7L14	38,560	17,270	56,440	[2] 25	130,990	[2] 3	1,200	1,129	760	[2] 10"	52,520	47-3/4"	9' 3-3/4"	5' 6-1/4"	14' 10"
ATWB 17-7M14	38,660	17,320	56,540	[2] 30	137,850	[2] 3	1,200	1,129	760	[2] 10"	52,620	47-3/4"	9' 3-3/4"	5' 6-1/4"	14' 10"

† Model Numbers end in "-Z" for units with Series Flow piping configuration. Series Flow units may require additional coil connections and will require crossover piping. Model numbers will include "C" for units with Stainless Steel coil(s), "R" for units with Low Sound Fan(s) and "S" for units with an option that negates CTI certification.

†† Heaviest section is the coil/fan section.

\* Gallons shown is water in suspension in unit and piping. Allow for additional water in bottom of remote sump to cover pump suction and strainer during operation (12" would normally be sufficient).

▲ When a remote sump arrangement is selected, the spray pump, suction strainer and associated piping are omitted; the unit is provided with an oversized outlet to facilitate drainage to the remote sump.

■ Unit dimensions and coil connections may vary slightly from catalog. See factory certified prints for dimensions, quantity of coil connections, and piping configuration. Coil connections are 4" bevel for weld (BFW). Other connection types such as grooved for mechanical coupling or flanged are also available as options.

# ATWB 10-3I12 to 10-7M12

Selections for ATWB Closed Circuit Coolers are available from EVAPCO's **SPECTRUM™** Program. Please contact your local sales representative for more information on the **SPECTRUM™** program.

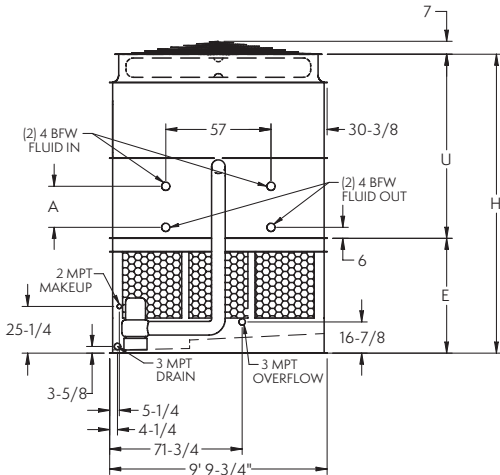
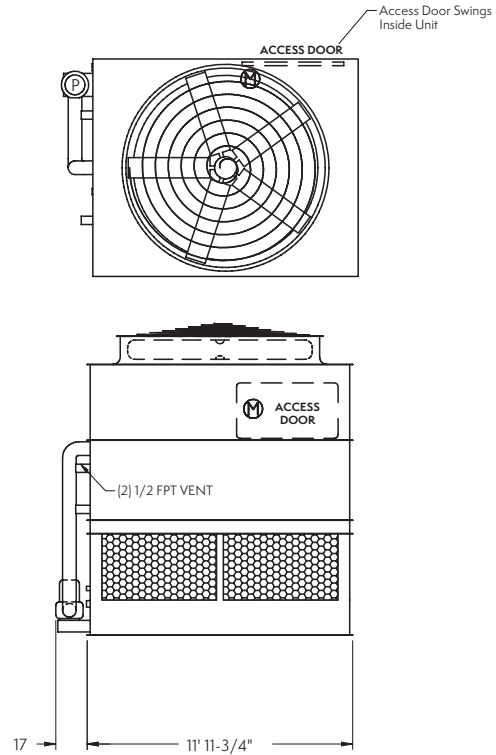

NOTE: The number of coil connections doubles when the flow rate exceeds 900 GPM on ATWB 10x12 models. This required option is referred to as the High Flow coil configuration.

ATWB Model Number†	Weights (lbs)			Fans		Spray Pump		Coil Volume (Gallons)	Remote Sump ▲			Dimensions ■			
	Shipping	Heaviest Section††	Operating	HP	CFM	HP	GPM		Gallons* Required	Conn. Size	Operating Weight (lbs)	Coil A	Upper U	Lower E	Height H
ATWB 10-3I12	12,390	9,840	19,900	10	55,680	5	685	253	420	12"	16,330	22-1/4"	8' 3-5/8"	5' 2-1/4"	13' 5-7/8"
ATWB 10-3J12	12,520	9,970	20,030	15	63,740	5	685	253	420	12"	16,460	22-1/4"	8' 3-5/8"	5' 2-1/4"	13' 5-7/8"
ATWB 10-3K12	12,580	10,030	20,090	20	69,520	5	685	253	420	12"	16,520	22-1/4"	8' 3-5/8"	5' 2-1/4"	13' 5-7/8"
ATWB 10-3L12	12,610	10,060	20,120	25	74,000	5	685	253	420	12"	16,550	22-1/4"	8' 3-5/8"	5' 2-1/4"	13' 5-7/8"
ATWB 10-3M12	12,660	10,110	20,170	30	77,870	5	685	253	420	12"	16,600	22-1/4"	8' 3-5/8"	5' 2-1/4"	13' 5-7/8"
ATWB 10-4I12	14,270	11,720	22,440	10	54,060	5	685	332	420	12"	18,870	30-3/4"	9' 1/8"	5' 2-1/4"	14' 2-3/8"
ATWB 10-4J12	14,400	11,850	22,570	15	61,880	5	685	332	420	12"	19,000	30-3/4"	9' 1/8"	5' 2-1/4"	14' 2-3/8"
ATWB 10-4K12	14,460	11,910	22,630	20	67,490	5	685	332	420	12"	19,060	30-3/4"	9' 1/8"	5' 2-1/4"	14' 2-3/8"
ATWB 10-4L12	14,490	11,940	22,660	25	71,840	5	685	332	420	12"	19,090	30-3/4"	9' 1/8"	5' 2-1/4"	14' 2-3/8"
ATWB 10-4M12	14,540	11,990	22,710	30	75,610	5	685	332	420	12"	19,140	30-3/4"	9' 1/8"	5' 2-1/4"	14' 2-3/8"
ATWB 10-5I12	16,050	13,500	24,880	10	52,440	5	685	411	420	12"	21,310	39-1/4"	9' 8-5/8"	5' 2-1/4"	14' 10-7/8"
ATWB 10-5J12	16,180	13,630	25,010	15	60,020	5	685	411	420	12"	21,440	39-1/4"	9' 8-5/8"	5' 2-1/4"	14' 10-7/8"
ATWB 10-5K12	16,240	13,690	25,070	20	65,470	5	685	411	420	12"	21,500	39-1/4"	9' 8-5/8"	5' 2-1/4"	14' 10-7/8"
ATWB 10-5L12	16,270	13,720	25,100	25	69,690	5	685	411	420	12"	21,530	39-1/4"	9' 8-5/8"	5' 2-1/4"	14' 10-7/8"
ATWB 10-5M12	16,320	13,770	25,150	30	73,340	5	685	411	420	12"	21,580	39-1/4"	9' 8-5/8"	5' 2-1/4"	14' 10-7/8"
ATWB 10-6I12	17,970	15,420	27,450	10	50,820	5	685	490	420	12"	23,880	47-3/4"	10' 5-1/8"	5' 2-1/4"	15' 7-3/8"
ATWB 10-6J12	18,100	15,550	27,580	15	58,170	5	685	490	420	12"	24,010	47-3/4"	10' 5-1/8"	5' 2-1/4"	15' 7-3/8"
ATWB 10-6K12	18,160	15,610	27,640	20	63,440	5	685	490	420	12"	24,070	47-3/4"	10' 5-1/8"	5' 2-1/4"	15' 7-3/8"
ATWB 10-6L12	18,190	15,640	27,670	25	67,530	5	685	490	420	12"	24,100	47-3/4"	10' 5-1/8"	5' 2-1/4"	15' 7-3/8"
ATWB 10-6M12	18,240	15,690	27,720	30	71,070	5	685	490	420	12"	24,150	47-3/4"	10' 5-1/8"	5' 2-1/4"	15' 7-3/8"
ATWB 10-7I12	20,210	17,660	30,350	10	49,190	5	685	569	420	12"	26,780	47-3/4"	10' 5-1/8"	5' 2-1/4"	15' 7-3/8"
ATWB 10-7J12	20,340	17,790	30,480	15	56,310	5	685	569	420	12"	26,910	47-3/4"	10' 5-1/8"	5' 2-1/4"	15' 7-3/8"
ATWB 10-7K12	20,400	17,850	30,540	20	61,420	5	685	569	420	12"	26,970	47-3/4"	10' 5-1/8"	5' 2-1/4"	15' 7-3/8"
ATWB 10-7L12	20,430	17,880	30,570	25	65,380	5	685	569	420	12"	27,000	47-3/4"	10' 5-1/8"	5' 2-1/4"	15' 7-3/8"
ATWB 10-7M12	20,480	17,930	30,620	30	68,800	5	685	569	420	12"	27,050	47-3/4"	10' 5-1/8"	5' 2-1/4"	15' 7-3/8"

† Model Numbers end in "-Z" for units with Series Flow piping configuration. Series Flow units may require additional coil connections and will require crossover piping. Model numbers will include "C" for units with Stainless Steel coil(s), "R" for units with Low Sound Fan(s) and "S" for units with an option that negates CTI certification.

†† Heaviest section is the coil/fan section.

\* Gallons shown is water in suspension in unit and piping. Allow for additional water in bottom of remote sump to cover pump suction and strainer during operation (12" would normally be sufficient).

▲ When a remote sump arrangement is selected, the spray pump, suction strainer and associated piping are omitted; the unit is provided with an oversized outlet to facilitate drainage to the remote sump.

■ Unit dimensions and coil connections may vary slightly from catalog. See factory certified prints for dimensions, quantity of coil connections, and piping configuration. Coil connections are 4" bevel for weld (BFW). Other connection types such as grooved for mechanical coupling or flanged are also available as options.



# ATWB 10-3I18 to 10-7N18

Selections for ATWB Closed Circuit Coolers are available from EVAPCO's **SPECTRUM™** Program. Please contact your local sales representative for more information on the **SPECTRUM™** program.

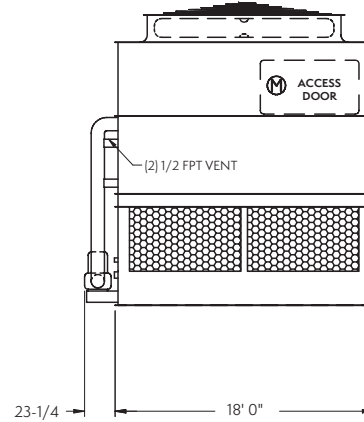
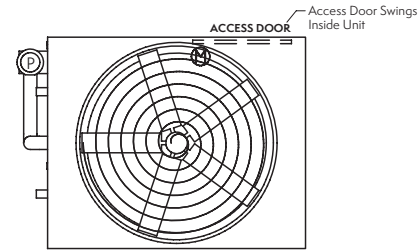
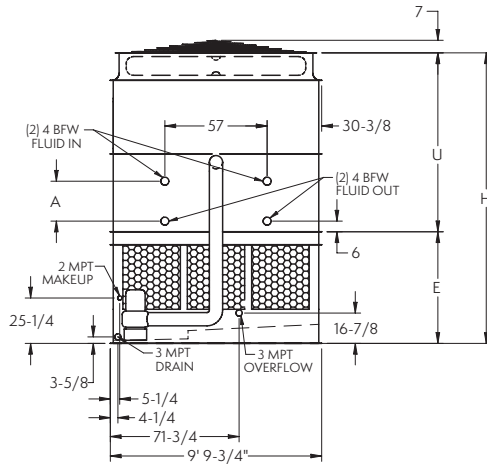

NOTE: The number of coil connections doubles when the flow rate exceeds 900 GPM on ATWB 10x18 models. This required option is referred to as the High Flow coil configuration.

ATWB Model Number†	Weights (lbs)			Fans		Spray Pump		Coil		Remote Sump <sup>△</sup>			Dimensions <sup>■</sup>			
	Shipping	Heaviest Section††	Operating	HP	CFM	HP	GPM	Volume (Gallons)	Gallons* Required	Conn. Size	Operating Weight (lbs)	Coil A	Upper U	Lower E	Height H	
ATWB 10-3I18	17,630	13,980	28,910	10	73,130	7 1/2	1,030	374	630	12"	23,660	22-1/4"	8' 3-5/8"	5' 2-1/4"	13' 5-7/8"	
ATWB 10-3J18	17,760	14,110	29,040	15	83,710	7 1/2	1,030	374	630	12"	23,790	22-1/4"	8' 3-5/8"	5' 2-1/4"	13' 5-7/8"	
ATWB 10-3K18	17,820	14,170	29,100	20	92,130	7 1/2	1,030	374	630	12"	23,850	22-1/4"	8' 3-5/8"	5' 2-1/4"	13' 5-7/8"	
ATWB 10-3L18	17,850	14,200	29,130	25	99,250	7 1/2	1,030	374	630	12"	23,880	22-1/4"	8' 3-5/8"	5' 2-1/4"	13' 5-7/8"	
ATWB 10-3M18	17,900	14,250	29,180	30	104,530	7 1/2	1,030	374	630	12"	23,930	22-1/4"	8' 3-5/8"	5' 2-1/4"	13' 5-7/8"	
ATWB 10-3N18	18,060	14,410	29,340	40	113,300	7 1/2	1,030	374	630	12"	24,090	22-1/4"	8' 3-5/8"	5' 2-1/4"	13' 5-7/8"	
ATWB 10-4I18	20,420	16,770	32,690	10	71,000	7 1/2	1,030	494	630	12"	27,440	30-3/4"	9' 1/8"	5' 2-1/4"	14' 2-3/8"	
ATWB 10-4J18	20,550	16,900	32,820	15	81,270	7 1/2	1,030	494	630	12"	27,570	30-3/4"	9' 1/8"	5' 2-1/4"	14' 2-3/8"	
ATWB 10-4K18	20,610	16,960	32,880	20	89,450	7 1/2	1,030	494	630	12"	27,630	30-3/4"	9' 1/8"	5' 2-1/4"	14' 2-3/8"	
ATWB 10-4L18	20,640	16,990	32,910	25	96,360	7 1/2	1,030	494	630	12"	27,660	30-3/4"	9' 1/8"	5' 2-1/4"	14' 2-3/8"	
ATWB 10-4M18	20,690	17,040	32,960	30	101,480	7 1/2	1,030	494	630	12"	27,710	30-3/4"	9' 1/8"	5' 2-1/4"	14' 2-3/8"	
ATWB 10-4N18	20,850	17,200	33,120	40	110,000	7 1/2	1,030	494	630	12"	27,870	30-3/4"	9' 1/8"	5' 2-1/4"	14' 2-3/8"	
ATWB 10-5I18	23,130	19,480	36,400	10	68,870	7 1/2	1,030	613	630	12"	31,150	39-1/4"	9' 8-5/8"	5' 2-1/4"	14' 10-7/8"	
ATWB 10-5J18	23,260	19,610	36,530	15	78,830	7 1/2	1,030	613	630	12"	31,280	39-1/4"	9' 8-5/8"	5' 2-1/4"	14' 10-7/8"	
ATWB 10-5K18	23,320	19,670	36,590	20	86,770	7 1/2	1,030	613	630	12"	31,340	39-1/4"	9' 8-5/8"	5' 2-1/4"	14' 10-7/8"	
ATWB 10-5L18	23,350	19,700	36,620	25	93,470	7 1/2	1,030	613	630	12"	31,370	39-1/4"	9' 8-5/8"	5' 2-1/4"	14' 10-7/8"	
ATWB 10-5M18	23,400	19,750	36,670	30	98,440	7 1/2	1,030	613	630	12"	31,420	39-1/4"	9' 8-5/8"	5' 2-1/4"	14' 10-7/8"	
ATWB 10-5N18	23,560	19,910	36,830	40	106,700	7 1/2	1,030	613	630	12"	31,580	39-1/4"	9' 8-5/8"	5' 2-1/4"	14' 10-7/8"	
ATWB 10-6I18	25,990	22,340	40,250	10	66,740	7 1/2	1,030	732	630	12"	35,000	47-3/4"	10' 5-1/8"	5' 2-1/4"	15' 7-3/8"	
ATWB 10-6J18	26,120	22,470	40,380	15	76,400	7 1/2	1,030	732	630	12"	35,130	47-3/4"	10' 5-1/8"	5' 2-1/4"	15' 7-3/8"	
ATWB 10-6K18	26,180	22,530	40,440	20	84,080	7 1/2	1,030	732	630	12"	35,190	47-3/4"	10' 5-1/8"	5' 2-1/4"	15' 7-3/8"	
ATWB 10-6L18	26,210	22,560	40,470	25	90,580	7 1/2	1,030	732	630	12"	35,220	47-3/4"	10' 5-1/8"	5' 2-1/4"	15' 7-3/8"	
ATWB 10-6M18	26,260	22,610	40,520	30	95,400	7 1/2	1,030	732	630	12"	35,270	47-3/4"	10' 5-1/8"	5' 2-1/4"	15' 7-3/8"	
ATWB 10-6N18	26,420	22,770	40,680	40	103,400	7 1/2	1,030	732	630	12"	35,430	47-3/4"	10' 5-1/8"	5' 2-1/4"	15' 7-3/8"	
ATWB 10-7I18	29,350	25,700	44,610	10	64,610	7 1/2	1,030	851	630	12"	39,360	47-3/4"	10' 5-1/8"	5' 2-1/4"	15' 7-3/8"	
ATWB 10-7J18	29,480	25,830	44,740	15	73,960	7 1/2	1,030	851	630	12"	39,490	47-3/4"	10' 5-1/8"	5' 2-1/4"	15' 7-3/8"	
ATWB 10-7K18	29,540	25,890	44,800	20	81,400	7 1/2	1,030	851	630	12"	39,550	47-3/4"	10' 5-1/8"	5' 2-1/4"	15' 7-3/8"	
ATWB 10-7L18	29,570	25,920	44,830	25	87,680	7 1/2	1,030	851	630	12"	39,580	47-3/4"	10' 5-1/8"	5' 2-1/4"	15' 7-3/8"	
ATWB 10-7M18	29,620	25,970	44,880	30	92,350	7 1/2	1,030	851	630	12"	39,630	47-3/4"	10' 5-1/8"	5' 2-1/4"	15' 7-3/8"	
ATWB 10-7N18	29,780	26,130	45,040	40	100,100	7 1/2	1,030	851	630	12"	39,790	47-3/4"	10' 5-1/8"	5' 2-1/4"	15' 7-3/8"	

† Model Numbers end in "-Z" for units with Series Flow piping configuration. Series Flow units may require additional coil connections and will require crossover piping. Model numbers will include "C" for units with Stainless Steel coil(s), "R" for units with Low Sound Fan(s) and "S" for units with an option that negates CTI certification.

†† Heaviest section is the coil/fan section.

\* Gallons shown is water in suspension in unit and piping. Allow for additional water in bottom of remote sump to cover pump suction and strainer during operation (12" would normally be sufficient).

△ When a remote sump arrangement is selected, the spray pump, suction strainer and associated piping are omitted; the unit is provided with an oversized outlet to facilitate drainage to the remote sump.

■ Unit dimensions and coil connections may vary slightly from catalog. See factory certified prints for dimensions, quantity of coil connections, and piping configuration. Coil connections are 4" bevel for weld (BFW). Other connection types such as grooved for mechanical coupling or flanged are also available as options.

# ATWB 10-3I24 to 10-7M24

Selections for ATWB Closed Circuit Coolers are available from EVAPCO's SPECTRUM™ Program. Please contact your local sales representative for more information on the SPECTRUM™ program.

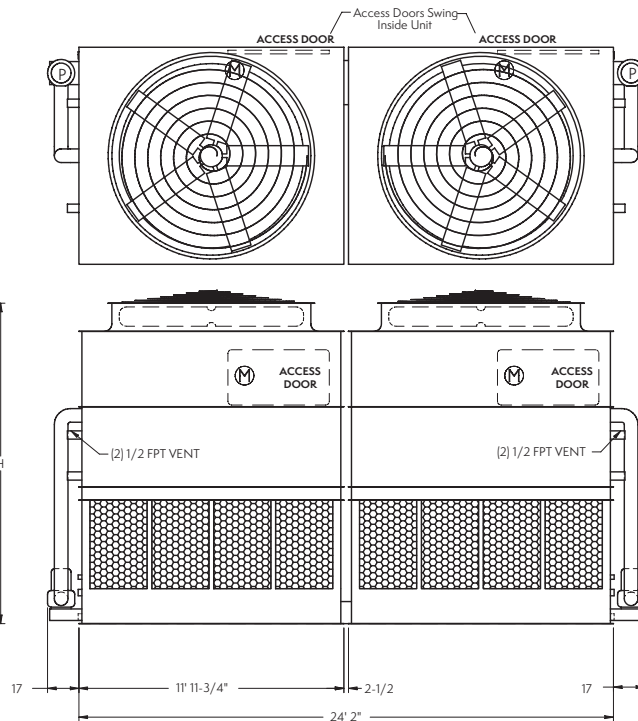
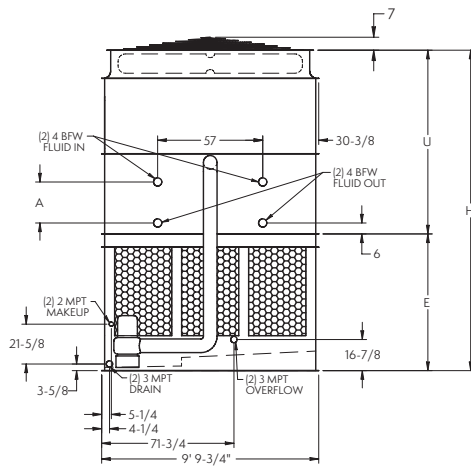

NOTE: The number of coil connections doubles when the flow rate exceeds 1,800 GPM on ATWB 10x24 models. This required option is referred to as the High Flow coil configuration.

ATWB Model Number†	Weights (lbs)			Fans		Spray Pump		Coil Volume (Gallons)	Remote Sump ▲			Dimensions ■			
	Shipping	Heaviest Section††	Operating	HP	CFM	HP	GPM		Gallons* Required	Conn. Size	Operating Weight (lbs)	Coil A	Upper U	Lower E	Height H
ATWB 10-3I24	25,040	9,840	40,060	2 10	111,360	2 5	1,370	507	840	2 12"	32,920	22-1/4"	8' 3-5/8"	6' 2-1/4"	14' 5-7/8"
ATWB 10-3J24	25,300	9,970	40,320	2 15	127,480	2 5	1,370	507	840	2 12"	33,180	22-1/4"	8' 3-5/8"	6' 2-1/4"	14' 5-7/8"
ATWB 10-3K24	25,420	10,030	40,440	2 20	139,030	2 5	1,370	507	840	2 12"	33,300	22-1/4"	8' 3-5/8"	6' 2-1/4"	14' 5-7/8"
ATWB 10-3L24	25,480	10,060	40,500	2 25	148,000	2 5	1,370	507	840	2 12"	33,360	22-1/4"	8' 3-5/8"	6' 2-1/4"	14' 5-7/8"
ATWB 10-3M24	25,580	10,110	40,600	2 30	155,750	2 5	1,370	507	840	2 12"	33,460	22-1/4"	8' 3-5/8"	6' 2-1/4"	14' 5-7/8"
ATWB 10-4I24	28,800	11,720	45,140	2 10	108,120	2 5	1,370	664	840	2 12"	38,000	30-3/4"	9' 1/8"	6' 2-1/4"	15' 2-3/8"
ATWB 10-4J24	29,060	11,850	45,400	2 15	123,760	2 5	1,370	664	840	2 12"	38,260	30-3/4"	9' 1/8"	6' 2-1/4"	15' 2-3/8"
ATWB 10-4K24	29,180	11,910	45,520	2 20	134,980	2 5	1,370	664	840	2 12"	38,380	30-3/4"	9' 1/8"	6' 2-1/4"	15' 2-3/8"
ATWB 10-4L24	29,240	11,940	45,580	2 25	143,690	2 5	1,370	664	840	2 12"	38,440	30-3/4"	9' 1/8"	6' 2-1/4"	15' 2-3/8"
ATWB 10-4M24	29,340	11,990	45,680	2 30	151,210	2 5	1,370	664	840	2 12"	38,540	30-3/4"	9' 1/8"	6' 2-1/4"	15' 2-3/8"
ATWB 10-5I24	32,360	13,500	50,020	2 10	104,870	2 5	1,370	822	840	2 12"	42,880	39-1/4"	9' 8-5/8"	6' 2-1/4"	15' 10-7/8"
ATWB 10-5J24	32,620	13,630	50,280	2 15	120,050	2 5	1,370	822	840	2 12"	43,140	39-1/4"	9' 8-5/8"	6' 2-1/4"	15' 10-7/8"
ATWB 10-5K24	32,740	13,690	50,400	2 20	130,930	2 5	1,370	822	840	2 12"	43,260	39-1/4"	9' 8-5/8"	6' 2-1/4"	15' 10-7/8"
ATWB 10-5L24	32,800	13,720	50,460	2 25	139,380	2 5	1,370	822	840	2 12"	43,320	39-1/4"	9' 8-5/8"	6' 2-1/4"	15' 10-7/8"
ATWB 10-5M24	32,900	13,770	50,560	2 30	146,680	2 5	1,370	822	840	2 12"	43,420	39-1/4"	9' 8-5/8"	6' 2-1/4"	15' 10-7/8"
ATWB 10-6I24	36,200	15,420	55,160	2 10	101,630	2 5	1,370	980	840	2 12"	48,020	47-3/4"	10' 5-1/8"	6' 2-1/4"	16' 7-3/8"
ATWB 10-6J24	36,460	15,550	55,420	2 15	116,340	2 5	1,370	980	840	2 12"	48,280	47-3/4"	10' 5-1/8"	6' 2-1/4"	16' 7-3/8"
ATWB 10-6K24	36,580	15,610	55,540	2 20	126,880	2 5	1,370	980	840	2 12"	48,400	47-3/4"	10' 5-1/8"	6' 2-1/4"	16' 7-3/8"
ATWB 10-6L24	36,640	15,640	55,600	2 25	135,060	2 5	1,370	980	840	2 12"	48,460	47-3/4"	10' 5-1/8"	6' 2-1/4"	16' 7-3/8"
ATWB 10-6M24	36,740	15,690	55,700	2 30	142,140	2 5	1,370	980	840	2 12"	48,560	47-3/4"	10' 5-1/8"	6' 2-1/4"	16' 7-3/8"
ATWB 10-7I24	40,680	17,660	60,960	2 10	98,390	2 5	1,370	1,138	840	2 12"	53,820	47-3/4"	10' 5-1/8"	6' 2-1/4"	16' 7-3/8"
ATWB 10-7J24	40,940	17,790	61,220	2 15	112,620	2 5	1,370	1,138	840	2 12"	54,080	47-3/4"	10' 5-1/8"	6' 2-1/4"	16' 7-3/8"
ATWB 10-7K24	41,060	17,850	61,340	2 20	122,830	2 5	1,370	1,138	840	2 12"	54,200	47-3/4"	10' 5-1/8"	6' 2-1/4"	16' 7-3/8"
ATWB 10-7L24	41,120	17,880	61,400	2 25	130,750	2 5	1,370	1,138	840	2 12"	54,260	47-3/4"	10' 5-1/8"	6' 2-1/4"	16' 7-3/8"
ATWB 10-7M24	41,220	17,930	61,500	2 30	137,600	2 5	1,370	1,138	840	2 12"	54,360	47-3/4"	10' 5-1/8"	6' 2-1/4"	16' 7-3/8"

† Model Numbers end in "-Z" for units with Series Flow piping configuration. Series Flow units may require additional coil connections and will require crossover piping. Model numbers will include "C" for units with Stainless Steel coil(s), "R" for units with Low Sound Fan(s) and "S" for units with an option that negates CTI certification.

†† Heaviest section is the coil/fan section.

\* Gallons shown is water in suspension in unit and piping. Allow for additional water in bottom of remote sump to cover pump suction and strainer during operation (12" would normally be sufficient).

▲ When a remote sump arrangement is selected, the spray pump, suction strainer and associated piping are omitted; the unit is provided with an oversized outlet to facilitate drainage to the remote sump.

■ Unit dimensions and coil connections may vary slightly from catalog. See factory certified prints for dimensions, quantity of coil connections, and piping configuration. Coil connections are 4" bevel for weld (BFW). Other connection types such as grooved for mechanical coupling or flanged are also available as options.

# ATWB 10-3136 to 10-7N36

Selections for ATWB Closed Circuit Coolers are available from EVAPCO's SPECTRUM™ Program. Please contact your local sales representative for more information on the SPECTRUM™ program.

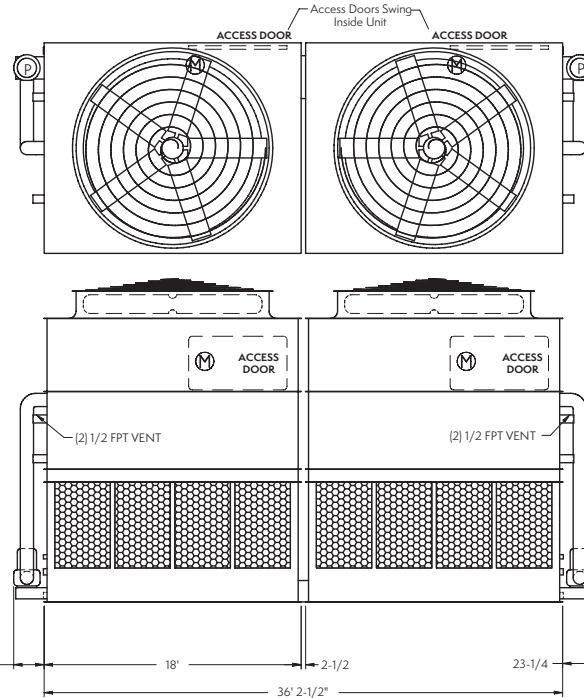
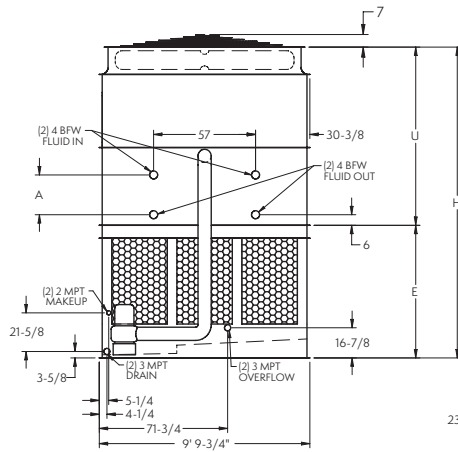

NOTE: The number of coil connections doubles when the flow rate exceeds 1,800 GPM on ATWB 10x36 models. This required option is referred to as the High Flow coil configuration.

ATWB Model Number†	Weights (lbs)			Fans		Spray Pump		Coil Volume (Gallons)	Remote Sump Δ			Dimensions ■			
	Shipping	Heaviest Section††	Operating	HP	CFM	HP	GPM		Gallons* Required	Conn. Size	Operating Weight (lbs)	Coil A	Upper U	Lower E	Height H
ATWB 10-3136	35,260	13,980	57,820	2 10	146,260	2 7.5	2,060	748	1,260	2 12"	47,320	22-1/4"	8' 3-5/8"	6' 2-1/4"	14' 5-7/8"
ATWB 10-3136	35,520	14,110	58,080	2 15	167,420	2 7.5	2,060	748	1,260	2 12"	47,580	22-1/4"	8' 3-5/8"	6' 2-1/4"	14' 5-7/8"
ATWB 10-3K36	35,640	14,170	58,200	2 20	184,270	2 7.5	2,060	748	1,260	2 12"	47,700	22-1/4"	8' 3-5/8"	6' 2-1/4"	14' 5-7/8"
ATWB 10-3L36	35,700	14,200	58,260	2 25	198,490	2 7.5	2,060	748	1,260	2 12"	47,760	22-1/4"	8' 3-5/8"	6' 2-1/4"	14' 5-7/8"
ATWB 10-3M36	35,800	14,250	58,360	2 30	209,060	2 7.5	2,060	748	1,260	2 12"	47,860	22-1/4"	8' 3-5/8"	6' 2-1/4"	14' 5-7/8"
ATWB 10-3N36	36,120	14,410	58,680	2 40	226,590	2 7.5	2,060	748	1,260	2 12"	48,180	22-1/4"	8' 3-5/8"	6' 2-1/4"	14' 5-7/8"
ATWB 10-4136	40,840	16,770	65,380	2 10	142,000	2 7.5	2,060	987	1,260	2 12"	54,880	30-3/4"	9' 1/8"	6' 2-1/4"	15' 2-3/8"
ATWB 10-4136	41,100	16,900	65,640	2 15	162,540	2 7.5	2,060	987	1,260	2 12"	55,140	30-3/4"	9' 1/8"	6' 2-1/4"	15' 2-3/8"
ATWB 10-4K36	41,220	16,960	65,760	2 20	178,900	2 7.5	2,060	987	1,260	2 12"	55,260	30-3/4"	9' 1/8"	6' 2-1/4"	15' 2-3/8"
ATWB 10-4L36	41,280	16,990	65,820	2 25	192,710	2 7.5	2,060	987	1,260	2 12"	55,320	30-3/4"	9' 1/8"	6' 2-1/4"	15' 2-3/8"
ATWB 10-4M36	41,380	17,040	65,920	2 30	202,970	2 7.5	2,060	987	1,260	2 12"	55,420	30-3/4"	9' 1/8"	6' 2-1/4"	15' 2-3/8"
ATWB 10-4N36	41,700	17,200	66,240	2 40	219,990	2 7.5	2,060	987	1,260	2 12"	55,740	30-3/4"	9' 1/8"	6' 2-1/4"	15' 2-3/8"
ATWB 10-5136	46,260	19,480	72,800	2 10	137,740	2 7.5	2,060	1,226	1,260	2 12"	62,300	39-1/4"	9' 8-5/8"	6' 2-1/4"	15' 10-7/8"
ATWB 10-5136	46,520	19,610	73,060	2 15	157,670	2 7.5	2,060	1,226	1,260	2 12"	62,560	39-1/4"	9' 8-5/8"	6' 2-1/4"	15' 10-7/8"
ATWB 10-5K36	46,640	19,670	73,180	2 20	173,530	2 7.5	2,060	1,226	1,260	2 12"	62,680	39-1/4"	9' 8-5/8"	6' 2-1/4"	15' 10-7/8"
ATWB 10-5L36	46,700	19,700	73,240	2 25	186,930	2 7.5	2,060	1,226	1,260	2 12"	62,740	39-1/4"	9' 8-5/8"	6' 2-1/4"	15' 10-7/8"
ATWB 10-5M36	46,800	19,750	73,340	2 30	196,880	2 7.5	2,060	1,226	1,260	2 12"	62,840	39-1/4"	9' 8-5/8"	6' 2-1/4"	15' 10-7/8"
ATWB 10-5N36	47,120	19,910	73,660	2 40	213,390	2 7.5	2,060	1,226	1,260	2 12"	63,160	39-1/4"	9' 8-5/8"	6' 2-1/4"	15' 10-7/8"
ATWB 10-6136	51,980	22,340	80,500	2 10	133,480	2 7.5	2,060	1,464	1,260	2 12"	70,000	47-3/4"	10' 5-1/8"	6' 2-1/4"	16' 7-3/8"
ATWB 10-6136	52,240	22,470	80,760	2 15	152,790	2 7.5	2,060	1,464	1,260	2 12"	70,260	47-3/4"	10' 5-1/8"	6' 2-1/4"	16' 7-3/8"
ATWB 10-6K36	52,360	22,530	80,880	2 20	168,170	2 7.5	2,060	1,464	1,260	2 12"	70,380	47-3/4"	10' 5-1/8"	6' 2-1/4"	16' 7-3/8"
ATWB 10-6L36	52,420	22,560	80,940	2 25	181,150	2 7.5	2,060	1,464	1,260	2 12"	70,440	47-3/4"	10' 5-1/8"	6' 2-1/4"	16' 7-3/8"
ATWB 10-6M36	52,520	22,610	81,040	2 30	190,790	2 7.5	2,060	1,464	1,260	2 12"	70,540	47-3/4"	10' 5-1/8"	6' 2-1/4"	16' 7-3/8"
ATWB 10-6N36	52,840	22,770	81,360	2 40	206,790	2 7.5	2,060	1,464	1,260	2 12"	70,860	47-3/4"	10' 5-1/8"	6' 2-1/4"	16' 7-3/8"
ATWB 10-7136	58,700	25,700	89,220	2 10	129,220	2 7.5	2,060	1,703	1,260	2 12"	78,720	47-3/4"	10' 5-1/8"	6' 2-1/4"	16' 7-3/8"
ATWB 10-7136	58,960	25,830	89,480	2 15	147,910	2 7.5	2,060	1,703	1,260	2 12"	78,980	47-3/4"	10' 5-1/8"	6' 2-1/4"	16' 7-3/8"
ATWB 10-7K36	59,080	25,890	89,600	2 20	162,800	2 7.5	2,060	1,703	1,260	2 12"	79,100	47-3/4"	10' 5-1/8"	6' 2-1/4"	16' 7-3/8"
ATWB 10-7L36	59,140	25,920	89,660	2 25	175,370	2 7.5	2,060	1,703	1,260	2 12"	79,160	47-3/4"	10' 5-1/8"	6' 2-1/4"	16' 7-3/8"
ATWB 10-7M36	59,240	25,970	89,760	2 30	184,700	2 7.5	2,060	1,703	1,260	2 12"	79,260	47-3/4"	10' 5-1/8"	6' 2-1/4"	16' 7-3/8"
ATWB 10-7N36	59,560	26,130	90,080	2 40	200,190	2 7.5	2,060	1,703	1,260	2 12"	79,580	47-3/4"	10' 5-1/8"	6' 2-1/4"	16' 7-3/8"

† Model Numbers end in "-Z" for units with Series Flow piping configuration. Series Flow units may require additional coil connections and will require crossover piping. Model numbers will include "C" for units with Stainless Steel coil(s), "R" for units with Low Sound Fan(s) and "S" for units with an option that negates CTI certification.

†† Heaviest section is the coil/fan section.

\* Gallons shown is water in suspension in unit and piping. Allow for additional water in bottom of remote sump to cover pump suction and strainer during operation (12" would normally be sufficient).

Δ When a remote sump arrangement is selected, the spray pump, suction strainer and associated piping are omitted; the unit is provided with an oversized outlet to facilitate drainage to the remote sump.

■ Unit dimensions and coil connections may vary slightly from catalog. See factory certified prints for dimensions, quantity of coil connections, and piping configuration. Coil connections are 4" bevel for weld (BFW). Other connection types such as grooved for mechanical coupling or flanged are also available as options.

# ATWB 20-3I12 to 20-7M12

Selections for ATWB Closed Circuit Coolers are available from EVAPCO's **SPECTRUM™** Program. Please contact your local sales representative for more information on the **SPECTRUM™** program.

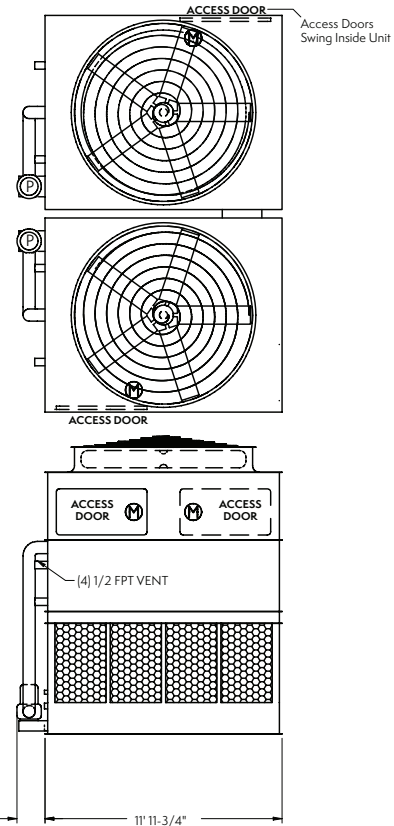
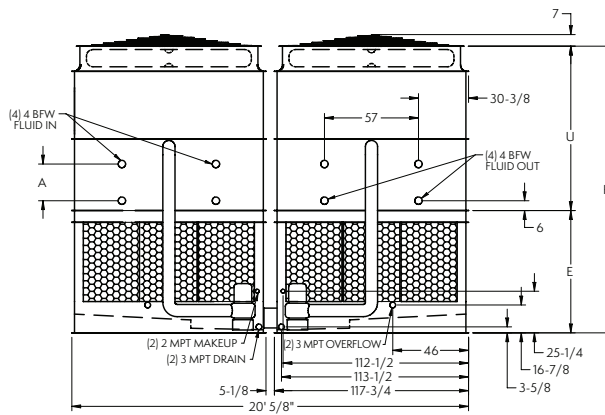

NOTE: The number of coil connections doubles when the flow rate exceeds 1,800 GPM on ATWB 20x12 models. This required option is referred to as the High Flow coil configuration.

ATWB Model Number†	Weights (lbs)			Fans		Spray Pump		Coil Volume (Gallons)	Remote Sump ▲			Dimensions ■			
	Shipping	Heaviest Section††	Operating	HP	CFM	HP	GPM		Gallons* Required	Conn. Size	Operating Weight (lbs)	Coil A	Upper U	Lower E	Height H
ATWB 20-3I12	24,800	9,840	39,820	2 10	111,360	2 5	1,370	507	840	2 12"	32,680	22-1/4"	8' 3-5/8"	6' 2-1/4"	14' 5-7/8"
ATWB 20-3J12	25,060	9,970	40,080	2 15	127,480	2 5	1,370	507	840	2 12"	32,940	22-1/4"	8' 3-5/8"	6' 2-1/4"	14' 5-7/8"
ATWB 20-3K12	25,180	10,030	40,200	2 20	139,030	2 5	1,370	507	840	2 12"	33,060	22-1/4"	8' 3-5/8"	6' 2-1/4"	14' 5-7/8"
ATWB 20-3L12	25,240	10,060	40,260	2 25	148,000	2 5	1,370	507	840	2 12"	33,120	22-1/4"	8' 3-5/8"	6' 2-1/4"	14' 5-7/8"
ATWB 20-3M12	25,340	10,110	40,360	2 30	155,750	2 5	1,370	507	840	2 12"	33,220	22-1/4"	8' 3-5/8"	6' 2-1/4"	14' 5-7/8"
ATWB 20-4I12	28,560	11,720	44,900	2 10	108,120	2 5	1,370	664	840	2 12"	37,760	30-3/4"	9' 1/8"	6' 2-1/4"	15' 2-3/8"
ATWB 20-4J12	28,820	11,850	45,160	2 15	123,760	2 5	1,370	664	840	2 12"	38,020	30-3/4"	9' 1/8"	6' 2-1/4"	15' 2-3/8"
ATWB 20-4K12	28,940	11,910	45,280	2 20	134,980	2 5	1,370	664	840	2 12"	38,140	30-3/4"	9' 1/8"	6' 2-1/4"	15' 2-3/8"
ATWB 20-4L12	29,000	11,940	45,340	2 25	143,690	2 5	1,370	664	840	2 12"	38,200	30-3/4"	9' 1/8"	6' 2-1/4"	15' 2-3/8"
ATWB 20-4M12	29,100	11,990	45,440	2 30	151,210	2 5	1,370	664	840	2 12"	38,300	30-3/4"	9' 1/8"	6' 2-1/4"	15' 2-3/8"
ATWB 20-5I12	32,120	13,500	49,780	2 10	104,870	2 5	1,370	822	840	2 12"	42,640	39-1/4"	9' 8-5/8"	6' 2-1/4"	15' 10-7/8"
ATWB 20-5J12	32,380	13,630	50,040	2 15	120,050	2 5	1,370	822	840	2 12"	42,900	39-1/4"	9' 8-5/8"	6' 2-1/4"	15' 10-7/8"
ATWB 20-5K12	32,500	13,690	50,160	2 20	130,930	2 5	1,370	822	840	2 12"	43,020	39-1/4"	9' 8-5/8"	6' 2-1/4"	15' 10-7/8"
ATWB 20-5L12	32,560	13,720	50,220	2 25	139,380	2 5	1,370	822	840	2 12"	43,080	39-1/4"	9' 8-5/8"	6' 2-1/4"	15' 10-7/8"
ATWB 20-5M12	32,660	13,770	50,320	2 30	146,680	2 5	1,370	822	840	2 12"	43,180	39-1/4"	9' 8-5/8"	6' 2-1/4"	15' 10-7/8"
ATWB 20-6I12	35,960	15,420	54,920	2 10	101,630	2 5	1,370	980	840	2 12"	47,780	47-3/4"	10' 5-1/8"	6' 2-1/4"	16' 7-3/8"
ATWB 20-6J12	36,220	15,550	55,180	2 15	116,340	2 5	1,370	980	840	2 12"	48,040	47-3/4"	10' 5-1/8"	6' 2-1/4"	16' 7-3/8"
ATWB 20-6K12	36,340	15,610	55,300	2 20	126,880	2 5	1,370	980	840	2 12"	48,160	47-3/4"	10' 5-1/8"	6' 2-1/4"	16' 7-3/8"
ATWB 20-6L12	36,400	15,640	55,360	2 25	135,060	2 5	1,370	980	840	2 12"	48,220	47-3/4"	10' 5-1/8"	6' 2-1/4"	16' 7-3/8"
ATWB 20-6M12	36,500	15,690	55,460	2 30	142,140	2 5	1,370	980	840	2 12"	48,320	47-3/4"	10' 5-1/8"	6' 2-1/4"	16' 7-3/8"
ATWB 20-7I12	40,440	17,660	60,720	2 10	98,390	2 5	1,370	1,138	840	2 12"	53,580	47-3/4"	10' 5-1/8"	6' 2-1/4"	16' 7-3/8"
ATWB 20-7J12	40,700	17,790	60,980	2 15	112,620	2 5	1,370	1,138	840	2 12"	53,840	47-3/4"	10' 5-1/8"	6' 2-1/4"	16' 7-3/8"
ATWB 20-7K12	40,820	17,850	61,100	2 20	122,830	2 5	1,370	1,138	840	2 12"	53,960	47-3/4"	10' 5-1/8"	6' 2-1/4"	16' 7-3/8"
ATWB 20-7L12	40,880	17,880	61,160	2 25	130,750	2 5	1,370	1,138	840	2 12"	54,020	47-3/4"	10' 5-1/8"	6' 2-1/4"	16' 7-3/8"
ATWB 20-7M12	40,980	17,930	61,260	2 30	137,600	2 5	1,370	1,138	840	2 12"	54,120	47-3/4"	10' 5-1/8"	6' 2-1/4"	16' 7-3/8"

† Model Numbers end in "-Z" for units with Series Flow piping configuration. Series Flow units may require additional coil connections and will require crossover piping. Model numbers will include "C" for units with Stainless Steel coil(s), "R" for units with Low Sound Fan(s) and "S" for units with an option that negates CTI certification.

†† Heaviest section is the coil/fan section.

\* Gallons shown is water in suspension in unit and piping. Allow for additional water in bottom of remote sump to cover pump suction and strainer during operation (12" would normally be sufficient).

▲ When a remote sump arrangement is selected, the spray pump, suction strainer and associated piping are omitted; the unit is provided with an oversized outlet to facilitate drainage to the remote sump.

■ Unit dimensions and coil connections may vary slightly from catalog. See factory certified prints for dimensions, quantity of coil connections, and piping configuration. Coil connections are 4" bevel for weld (BFW). Other connection types such as grooved for mechanical coupling or flanged are also available as options.



# ATWB 20-3I18 to 20-7N18

Selections for ATWB Closed Circuit Coolers are available from EVAPCO's **SPECTRUM™** Program. Please contact your local sales representative for more information on the **SPECTRUM™** program.

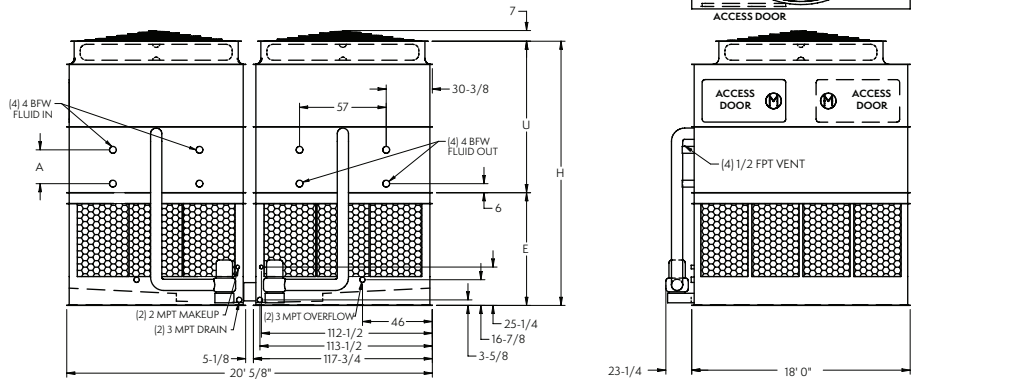

NOTE: The number of coil connections doubles when the flow rate exceeds 1,800 GPM on ATWB 20x18 models. This required option is referred to as the High Flow coil configuration.

ATWB Model Number†	Weights (lbs)			Fans		Spray Pump		Coil Volume (Gallons)	Remote Sump ▲			Dimensions ■			
	Shipping	Heaviest Section††	Operating	HP	CFM	HP	GPM		Gallons* Required	Conn. Size	Operating Weight (lbs)	Coil A	Upper U	Lower E	Height H
ATWB 20-3I18	35,300	13,980	57,860	2 10	146,260	2 7.5	2,060	748	1,260	2 12"	47,360	22-1/4"	8' 3-5/8"	7' 2-1/4"	15' 5-7/8"
ATWB 20-3J18	35,560	14,110	58,120	2 15	167,420	2 7.5	2,060	748	1,260	2 12"	47,620	22-1/4"	8' 3-5/8"	7' 2-1/4"	15' 5-7/8"
ATWB 20-3K18	35,680	14,170	58,240	2 20	184,270	2 7.5	2,060	748	1,260	2 12"	47,740	22-1/4"	8' 3-5/8"	7' 2-1/4"	15' 5-7/8"
ATWB 20-3L18	35,740	14,200	58,300	2 25	198,490	2 7.5	2,060	748	1,260	2 12"	47,800	22-1/4"	8' 3-5/8"	7' 2-1/4"	15' 5-7/8"
ATWB 20-3M18	35,840	14,250	58,400	2 30	209,060	2 7.5	2,060	748	1,260	2 12"	47,900	22-1/4"	8' 3-5/8"	7' 2-1/4"	15' 5-7/8"
ATWB 20-3N18	36,160	14,410	58,720	2 40	226,590	2 7.5	2,060	748	1,260	2 12"	48,220	22-1/4"	8' 3-5/8"	7' 2-1/4"	15' 5-7/8"
ATWB 20-4I18	40,880	16,770	65,420	2 10	142,000	2 7.5	2,060	987	1,260	2 12"	54,920	30-3/4"	9' 1/8"	7' 2-1/4"	16' 2-3/8"
ATWB 20-4J18	41,140	16,900	65,680	2 15	162,540	2 7.5	2,060	987	1,260	2 12"	55,180	30-3/4"	9' 1/8"	7' 2-1/4"	16' 2-3/8"
ATWB 20-4K18	41,260	16,960	65,800	2 20	178,900	2 7.5	2,060	987	1,260	2 12"	55,300	30-3/4"	9' 1/8"	7' 2-1/4"	16' 2-3/8"
ATWB 20-4L18	41,320	16,990	65,860	2 25	192,710	2 7.5	2,060	987	1,260	2 12"	55,360	30-3/4"	9' 1/8"	7' 2-1/4"	16' 2-3/8"
ATWB 20-4M18	41,420	17,040	65,960	2 30	202,970	2 7.5	2,060	987	1,260	2 12"	55,460	30-3/4"	9' 1/8"	7' 2-1/4"	16' 2-3/8"
ATWB 20-4N18	41,740	17,200	66,280	2 40	219,990	2 7.5	2,060	987	1,260	2 12"	55,780	30-3/4"	9' 1/8"	7' 2-1/4"	16' 2-3/8"
ATWB 20-5I18	46,300	19,480	72,840	2 10	137,740	2 7.5	2,060	1,226	1,260	2 12"	62,340	39-1/4"	9' 8-5/8"	7' 2-1/4"	16' 10-7/8"
ATWB 20-5J18	46,560	19,610	73,100	2 15	157,670	2 7.5	2,060	1,226	1,260	2 12"	62,600	39-1/4"	9' 8-5/8"	7' 2-1/4"	16' 10-7/8"
ATWB 20-5K18	46,680	19,670	73,220	2 20	173,530	2 7.5	2,060	1,226	1,260	2 12"	62,720	39-1/4"	9' 8-5/8"	7' 2-1/4"	16' 10-7/8"
ATWB 20-5L18	46,740	19,700	73,280	2 25	186,930	2 7.5	2,060	1,226	1,260	2 12"	62,780	39-1/4"	9' 8-5/8"	7' 2-1/4"	16' 10-7/8"
ATWB 20-5M18	46,840	19,750	73,380	2 30	196,880	2 7.5	2,060	1,226	1,260	2 12"	62,880	39-1/4"	9' 8-5/8"	7' 2-1/4"	16' 10-7/8"
ATWB 20-5N18	47,160	19,910	73,700	2 40	213,390	2 7.5	2,060	1,226	1,260	2 12"	63,200	39-1/4"	9' 8-5/8"	7' 2-1/4"	16' 10-7/8"
ATWB 20-6I18	52,020	22,340	80,540	2 10	133,480	2 7.5	2,060	1,464	1,260	2 12"	70,040	47-3/4"	10' 5-1/8"	7' 2-1/4"	17' 7-3/8"
ATWB 20-6J18	52,280	22,470	80,800	2 15	152,790	2 7.5	2,060	1,464	1,260	2 12"	70,300	47-3/4"	10' 5-1/8"	7' 2-1/4"	17' 7-3/8"
ATWB 20-6K18	52,400	22,530	80,920	2 20	168,170	2 7.5	2,060	1,464	1,260	2 12"	70,420	47-3/4"	10' 5-1/8"	7' 2-1/4"	17' 7-3/8"
ATWB 20-6L18	52,460	22,560	80,980	2 25	181,150	2 7.5	2,060	1,464	1,260	2 12"	70,480	47-3/4"	10' 5-1/8"	7' 2-1/4"	17' 7-3/8"
ATWB 20-6M18	52,560	22,610	81,080	2 30	190,790	2 7.5	2,060	1,464	1,260	2 12"	70,580	47-3/4"	10' 5-1/8"	7' 2-1/4"	17' 7-3/8"
ATWB 20-6N18	52,880	22,770	81,400	2 40	206,790	2 7.5	2,060	1,464	1,260	2 12"	70,900	47-3/4"	10' 5-1/8"	7' 2-1/4"	17' 7-3/8"
ATWB 20-7I18	58,740	25,700	89,260	2 10	129,220	2 7.5	2,060	1,703	1,260	2 12"	78,760	47-3/4"	10' 5-1/8"	7' 2-1/4"	17' 7-3/8"
ATWB 20-7J18	59,000	25,830	89,520	2 15	147,910	2 7.5	2,060	1,703	1,260	2 12"	79,020	47-3/4"	10' 5-1/8"	7' 2-1/4"	17' 7-3/8"
ATWB 20-7K18	59,120	25,890	89,640	2 20	162,800	2 7.5	2,060	1,703	1,260	2 12"	79,140	47-3/4"	10' 5-1/8"	7' 2-1/4"	17' 7-3/8"
ATWB 20-7L18	59,180	25,920	89,700	2 25	175,370	2 7.5	2,060	1,703	1,260	2 12"	79,200	47-3/4"	10' 5-1/8"	7' 2-1/4"	17' 7-3/8"
ATWB 20-7M18	59,280	25,970	89,800	2 30	184,700	2 7.5	2,060	1,703	1,260	2 12"	79,300	47-3/4"	10' 5-1/8"	7' 2-1/4"	17' 7-3/8"
ATWB 20-7N18	59,600	26,130	90,120	2 40	200,190	2 7.5	2,060	1,703	1,260	2 12"	79,620	47-3/4"	10' 5-1/8"	7' 2-1/4"	17' 7-3/8"

† Model Numbers end in "-Z" for units with Series Flow piping configuration. Series Flow units may require additional coil connections and will require crossover piping. Model numbers will include "C" for units with Stainless Steel coil(s), "R" for units with Low Sound Fan(s) and "S" for units with an option that negates CTI certification.

†† Heaviest section is the coil/fan section.

\* Gallons shown is water in suspension in unit and piping. Allow for additional water in bottom of remote sump to cover pump suction and strainer during operation (12" would normally be sufficient).

▲ When a remote sump arrangement is selected, the spray pump, suction strainer and associated piping are omitted; the unit is provided with an oversized outlet to facilitate drainage to the remote sump.

■ Unit dimensions and coil connections may vary slightly from catalog. See factory certified prints for dimensions, quantity of coil connections, and piping configuration. Coil connections are 4" bevel for weld (BFW). Other connection types such as grooved for mechanical coupling or flanged are also available as options.

# ATWB 20-3124 to 20-7M24

Selections for ATWB Closed Circuit Coolers are available from EVAPCO's **SPECTRUM™** Program. Please contact your local sales representative for more information on the **SPECTRUM™** program.

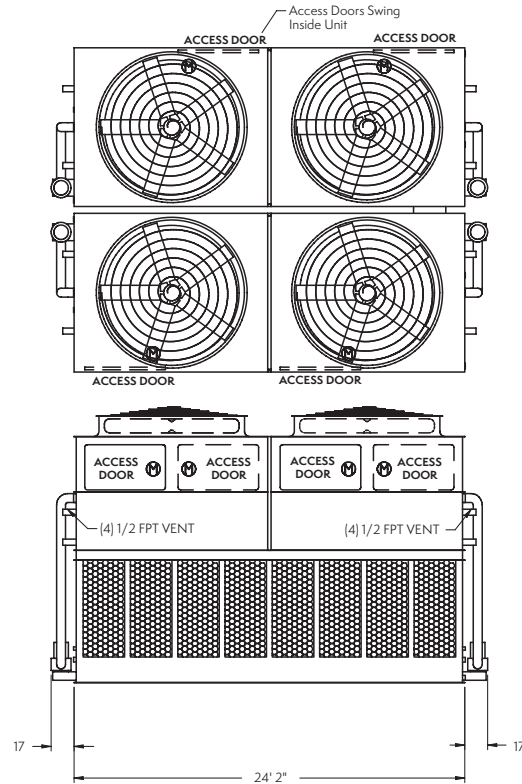
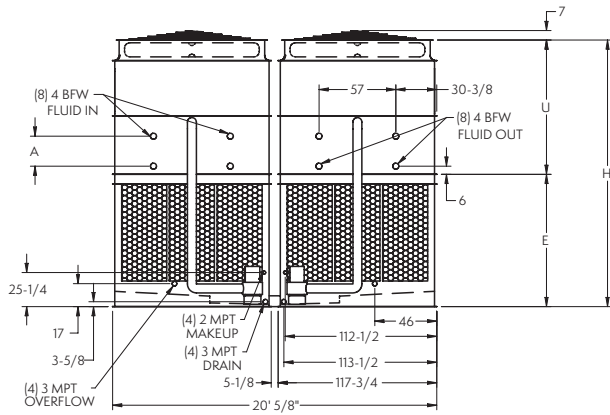

NOTE: The number of coil connections doubles when the flow rate exceeds 3,600 GPM on ATWB 20x24 models. This required option is referred to as the High Flow coil configuration.

ATWB Model Number†	Weights (lbs)			Fans		Spray Pump		Coil Volume (Gallons)	Remote Sump ▲			Dimensions ■			
	Shipping	Heaviest Section††	Operating	HP	CFM	HP	GPM		Gallons* Required	Conn. Size	Operating Weight (lbs)	Coil A	Upper U	Lower E	Height H
ATWB 20-3124	50,180	9,840	80,200	(4) 10	222,720	(4) 5	2,740	1,013	1,680	(4) 12"	65,920	22-1/4"	8' 3-5/8"	8' 2-1/4"	16' 5-7/8"
ATWB 20-3J24	50,700	9,970	80,720	(4) 15	254,950	(4) 5	2,740	1,013	1,680	(4) 12"	66,440	22-1/4"	8' 3-5/8"	8' 2-1/4"	16' 5-7/8"
ATWB 20-3K24	50,940	10,030	80,960	(4) 20	278,070	(4) 5	2,740	1,013	1,680	(4) 12"	66,680	22-1/4"	8' 3-5/8"	8' 2-1/4"	16' 5-7/8"
ATWB 20-3L24	51,060	10,060	81,080	(4) 25	295,990	(4) 5	2,740	1,013	1,680	(4) 12"	66,800	22-1/4"	8' 3-5/8"	8' 2-1/4"	16' 5-7/8"
ATWB 20-3M24	51,260	10,110	81,280	(4) 30	311,500	(4) 5	2,740	1,013	1,680	(4) 12"	67,000	22-1/4"	8' 3-5/8"	8' 2-1/4"	16' 5-7/8"
ATWB 20-4124	57,700	11,720	90,360	(4) 10	216,240	(4) 5	2,740	1,329	1,680	(4) 12"	76,080	30-3/4"	9' 1/8"	8' 2-1/4"	17' 2-3/8"
ATWB 20-4J24	58,220	11,850	90,880	(4) 15	247,530	(4) 5	2,740	1,329	1,680	(4) 12"	76,600	30-3/4"	9' 1/8"	8' 2-1/4"	17' 2-3/8"
ATWB 20-4K24	58,460	11,910	91,120	(4) 20	269,970	(4) 5	2,740	1,329	1,680	(4) 12"	76,840	30-3/4"	9' 1/8"	8' 2-1/4"	17' 2-3/8"
ATWB 20-4L24	58,580	11,940	91,240	(4) 25	287,370	(4) 5	2,740	1,329	1,680	(4) 12"	76,960	30-3/4"	9' 1/8"	8' 2-1/4"	17' 2-3/8"
ATWB 20-4M24	58,780	11,990	91,440	(4) 30	302,420	(4) 5	2,740	1,329	1,680	(4) 12"	77,160	30-3/4"	9' 1/8"	8' 2-1/4"	17' 2-3/8"
ATWB 20-5124	64,820	13,500	100,120	(4) 10	209,750	(4) 5	2,740	1,645	1,680	(4) 12"	85,840	39-1/4"	9' 8-5/8"	8' 2-1/4"	17' 10-7/8"
ATWB 20-5J24	65,340	13,630	100,640	(4) 15	240,100	(4) 5	2,740	1,645	1,680	(4) 12"	86,360	39-1/4"	9' 8-5/8"	8' 2-1/4"	17' 10-7/8"
ATWB 20-5K24	65,580	13,690	100,880	(4) 20	261,870	(4) 5	2,740	1,645	1,680	(4) 12"	86,600	39-1/4"	9' 8-5/8"	8' 2-1/4"	17' 10-7/8"
ATWB 20-5L24	65,700	13,720	101,000	(4) 25	278,750	(4) 5	2,740	1,645	1,680	(4) 12"	86,720	39-1/4"	9' 8-5/8"	8' 2-1/4"	17' 10-7/8"
ATWB 20-5M24	65,900	13,770	101,200	(4) 30	293,350	(4) 5	2,740	1,645	1,680	(4) 12"	86,920	39-1/4"	9' 8-5/8"	8' 2-1/4"	17' 10-7/8"
ATWB 20-6124	72,500	15,420	110,400	(4) 10	203,260	(4) 5	2,740	1,961	1,680	(4) 12"	96,120	47-3/4"	10' 5-1/8"	8' 2-1/4"	18' 7-3/8"
ATWB 20-6J24	73,020	15,550	110,920	(4) 15	232,670	(4) 5	2,740	1,961	1,680	(4) 12"	96,640	47-3/4"	10' 5-1/8"	8' 2-1/4"	18' 7-3/8"
ATWB 20-6K24	73,260	15,610	111,160	(4) 20	253,770	(4) 5	2,740	1,961	1,680	(4) 12"	96,880	47-3/4"	10' 5-1/8"	8' 2-1/4"	18' 7-3/8"
ATWB 20-6L24	73,380	15,640	111,280	(4) 25	270,130	(4) 5	2,740	1,961	1,680	(4) 12"	97,000	47-3/4"	10' 5-1/8"	8' 2-1/4"	18' 7-3/8"
ATWB 20-6M24	73,580	15,690	111,480	(4) 30	284,280	(4) 5	2,740	1,961	1,680	(4) 12"	97,200	47-3/4"	10' 5-1/8"	8' 2-1/4"	18' 7-3/8"
ATWB 20-7124	81,460	17,660	122,000	(4) 10	196,770	(4) 5	2,740	2,276	1,680	(4) 12"	107,720	47-3/4"	10' 5-1/8"	8' 2-1/4"	18' 7-3/8"
ATWB 20-7J24	81,980	17,790	122,520	(4) 15	225,250	(4) 5	2,740	2,276	1,680	(4) 12"	108,240	47-3/4"	10' 5-1/8"	8' 2-1/4"	18' 7-3/8"
ATWB 20-7K24	82,220	17,850	122,760	(4) 20	245,670	(4) 5	2,740	2,276	1,680	(4) 12"	108,480	47-3/4"	10' 5-1/8"	8' 2-1/4"	18' 7-3/8"
ATWB 20-7L24	82,340	17,880	122,880	(4) 25	261,510	(4) 5	2,740	2,276	1,680	(4) 12"	108,600	47-3/4"	10' 5-1/8"	8' 2-1/4"	18' 7-3/8"
ATWB 20-7M24	82,540	17,930	123,080	(4) 30	275,210	(4) 5	2,740	2,276	1,680	(4) 12"	108,800	47-3/4"	10' 5-1/8"	8' 2-1/4"	18' 7-3/8"

† Model Numbers end in "-Z" for units with Series Flow piping configuration. Series Flow units may require additional coil connections and will require crossover piping. Model numbers will include "C" for units with Stainless Steel coil(s), "R" for units with Low Sound Fan(s) and "S" for units with an option that negates CTI certification.

†† Heaviest section is the coil/fan section.

\* Gallons shown is water in suspension in unit and piping. Allow for additional water in bottom of remote sump to cover pump suction and strainer during operation (12" would normally be sufficient).

▲ When a remote sump arrangement is selected, the spray pump, suction strainer and associated piping are omitted; the unit is provided with an oversized outlet to facilitate drainage to the remote sump.

■ Unit dimensions and coil connections may vary slightly from catalog. See factory certified prints for dimensions, quantity of coil connections, and piping configuration. Coil connections are 4" bevel for weld (BFW). Other connection types such as grooved for mechanical coupling or flanged are also available as options.

# ATWB 20-3I36 to 20-7N36

Selections for ATWB Closed Circuit Coolers are available from EVAPCO's **SPECTRUM™** Program. Please contact your local sales representative for more information on the **SPECTRUM™** program.

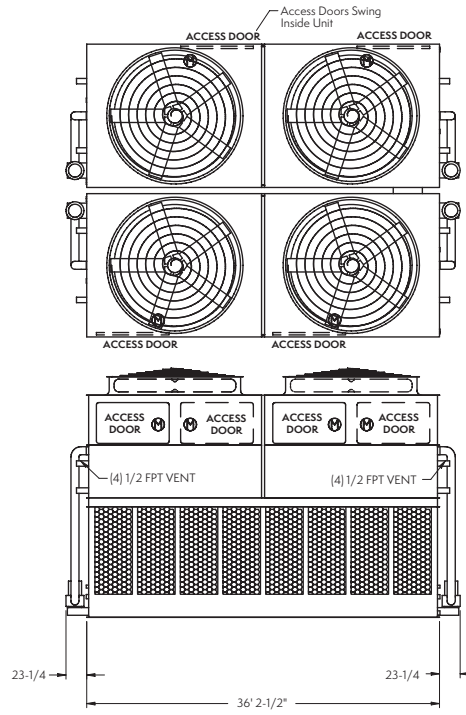
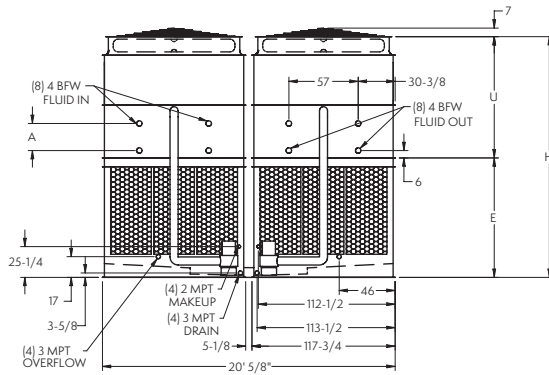

NOTE: The number of coil connections doubles when the flow rate exceeds 3,600 GPM on ATWB 20x36 models. This required option is referred to as the High Flow coil configuration.

ATWB Model Number†	Weights (lbs)			Fans		Spray Pump		Coil Volume (Gallons)	Remote Sump ▲			Dimensions ■			
	Shipping	Heaviest Section††	Operating	HP	CFM	HP	GPM		Gallons* <sup>2</sup> Required	Conn. Size	Operating Weight (lbs)	Coil A	Upper U	Lower E	Height H
ATWB 20-3I36	71,200	13,980	116,640	4 10	292,510	4 7.5	4,120	1,497	2,520	4 12"	95,660	22-1/4"	8' 3-5/8"	8' 2-1/4"	16' 5-7/8"
ATWB 20-3J36	71,720	14,110	117,160	4 15	334,840	4 7.5	4,120	1,497	2,520	4 12"	96,180	22-1/4"	8' 3-5/8"	8' 2-1/4"	16' 5-7/8"
ATWB 20-3K36	71,960	14,170	117,400	4 20	368,530	4 7.5	4,120	1,497	2,520	4 12"	96,420	22-1/4"	8' 3-5/8"	8' 2-1/4"	16' 5-7/8"
ATWB 20-3L36	72,080	14,200	117,520	4 25	396,990	4 7.5	4,120	1,497	2,520	4 12"	96,540	22-1/4"	8' 3-5/8"	8' 2-1/4"	16' 5-7/8"
ATWB 20-3M36	72,280	14,250	117,720	4 30	418,120	4 7.5	4,120	1,497	2,520	4 12"	96,740	22-1/4"	8' 3-5/8"	8' 2-1/4"	16' 5-7/8"
ATWB 20-3N36	72,920	14,410	118,360	4 40	453,190	4 7.5	4,120	1,497	2,520	4 12"	97,380	22-1/4"	8' 3-5/8"	8' 2-1/4"	16' 5-7/8"
ATWB 20-4I36	82,360	16,770	131,760	4 10	283,990	4 7.5	4,120	1,974	2,520	4 12"	110,780	30-3/4"	9' 1/8"	8' 2-1/4"	17' 2-3/8"
ATWB 20-4J36	82,880	16,900	132,280	4 15	325,090	4 7.5	4,120	1,974	2,520	4 12"	111,300	30-3/4"	9' 1/8"	8' 2-1/4"	17' 2-3/8"
ATWB 20-4K36	83,120	16,960	132,520	4 20	357,800	4 7.5	4,120	1,974	2,520	4 12"	111,540	30-3/4"	9' 1/8"	8' 2-1/4"	17' 2-3/8"
ATWB 20-4L36	83,240	16,990	132,640	4 25	385,430	4 7.5	4,120	1,974	2,520	4 12"	111,660	30-3/4"	9' 1/8"	8' 2-1/4"	17' 2-3/8"
ATWB 20-4M36	83,440	17,040	132,840	4 30	405,940	4 7.5	4,120	1,974	2,520	4 12"	111,860	30-3/4"	9' 1/8"	8' 2-1/4"	17' 2-3/8"
ATWB 20-4N36	84,080	17,200	133,480	4 40	439,990	4 7.5	4,120	1,974	2,520	4 12"	112,500	30-3/4"	9' 1/8"	8' 2-1/4"	17' 2-3/8"
ATWB 20-5I36	93,200	19,480	146,600	4 10	275,470	4 7.5	4,120	2,451	2,520	4 12"	125,620	39-1/4"	9' 8-5/8"	8' 2-1/4"	17' 10-7/8"
ATWB 20-5J36	93,720	19,610	147,120	4 15	315,330	4 7.5	4,120	2,451	2,520	4 12"	126,140	39-1/4"	9' 8-5/8"	8' 2-1/4"	17' 10-7/8"
ATWB 20-5K36	93,960	19,670	147,360	4 20	347,070	4 7.5	4,120	2,451	2,520	4 12"	126,380	39-1/4"	9' 8-5/8"	8' 2-1/4"	17' 10-7/8"
ATWB 20-5L36	94,080	19,700	147,480	4 25	373,860	4 7.5	4,120	2,451	2,520	4 12"	126,500	39-1/4"	9' 8-5/8"	8' 2-1/4"	17' 10-7/8"
ATWB 20-5M36	94,280	19,750	147,680	4 30	393,760	4 7.5	4,120	2,451	2,520	4 12"	126,700	39-1/4"	9' 8-5/8"	8' 2-1/4"	17' 10-7/8"
ATWB 20-5N36	94,920	19,910	148,320	4 40	426,790	4 7.5	4,120	2,451	2,520	4 12"	127,340	39-1/4"	9' 8-5/8"	8' 2-1/4"	17' 10-7/8"
ATWB 20-6I36	104,640	22,340	162,000	4 10	266,950	4 7.5	4,120	2,928	2,520	4 12"	141,020	47-3/4"	10' 5-1/8"	8' 2-1/4"	18' 7-3/8"
ATWB 20-6J36	105,160	22,470	162,520	4 15	305,580	4 7.5	4,120	2,928	2,520	4 12"	141,540	47-3/4"	10' 5-1/8"	8' 2-1/4"	18' 7-3/8"
ATWB 20-6K36	105,400	22,530	162,760	4 20	336,330	4 7.5	4,120	2,928	2,520	4 12"	141,780	47-3/4"	10' 5-1/8"	8' 2-1/4"	18' 7-3/8"
ATWB 20-6L36	105,520	22,560	162,880	4 25	362,300	4 7.5	4,120	2,928	2,520	4 12"	141,900	47-3/4"	10' 5-1/8"	8' 2-1/4"	18' 7-3/8"
ATWB 20-6M36	105,720	22,610	163,080	4 30	381,580	4 7.5	4,120	2,928	2,520	4 12"	142,100	47-3/4"	10' 5-1/8"	8' 2-1/4"	18' 7-3/8"
ATWB 20-6N36	106,360	22,770	163,720	4 40	413,590	4 7.5	4,120	2,928	2,520	4 12"	142,740	47-3/4"	10' 5-1/8"	8' 2-1/4"	18' 7-3/8"
ATWB 20-7I36	118,080	25,700	179,440	4 10	258,430	4 7.5	4,120	3,405	2,520	4 12"	158,460	47-3/4"	10' 5-1/8"	8' 2-1/4"	18' 7-3/8"
ATWB 20-7J36	118,600	25,830	179,960	4 15	295,830	4 7.5	4,120	3,405	2,520	4 12"	158,980	47-3/4"	10' 5-1/8"	8' 2-1/4"	18' 7-3/8"
ATWB 20-7K36	118,840	25,890	180,200	4 20	325,600	4 7.5	4,120	3,405	2,520	4 12"	159,220	47-3/4"	10' 5-1/8"	8' 2-1/4"	18' 7-3/8"
ATWB 20-7L36	118,960	25,920	180,320	4 25	350,740	4 7.5	4,120	3,405	2,520	4 12"	159,340	47-3/4"	10' 5-1/8"	8' 2-1/4"	18' 7-3/8"
ATWB 20-7M36	119,160	25,970	180,520	4 30	369,400	4 7.5	4,120	3,405	2,520	4 12"	159,540	47-3/4"	10' 5-1/8"	8' 2-1/4"	18' 7-3/8"
ATWB 20-7N36	119,800	26,130	181,160	4 40	400,390	4 7.5	4,120	3,405	2,520	4 12"	160,180	47-3/4"	10' 5-1/8"	8' 2-1/4"	18' 7-3/8"

† Model Numbers end in "-Z" for units with Series Flow piping configuration. Series Flow units may require additional coil connections and will require crossover piping. Model numbers will include "C" for units with Stainless Steel coil(s), "R" for units with Low Sound Fan(s) and "S" for units with an option that negates CTI certification.

†† Heaviest section is the coil/fan section.

\* Gallons shown is water in suspension in unit and piping. Allow for additional water in bottom of remote sump to cover pump suction and strainer during operation (12" would normally be sufficient).

▲ When a remote sump arrangement is selected, the spray pump, suction strainer and associated piping are omitted; the unit is provided with an oversized outlet to facilitate drainage to the remote sump.

■ Unit dimensions and coil connections may vary slightly from catalog. See factory certified prints for dimensions, quantity of coil connections, and piping configuration. Coil connections are 4" bevel for weld (BFW). Other connection types such as grooved for mechanical coupling or flanged are also available as options.

# ATWB 12-3J12 to 12-7N12

Selections for ATWB Closed Circuit Coolers are available from EVAPCO's **SPECTRUM™** Program. Please contact your local sales representative for more information on the **SPECTRUM™** program.

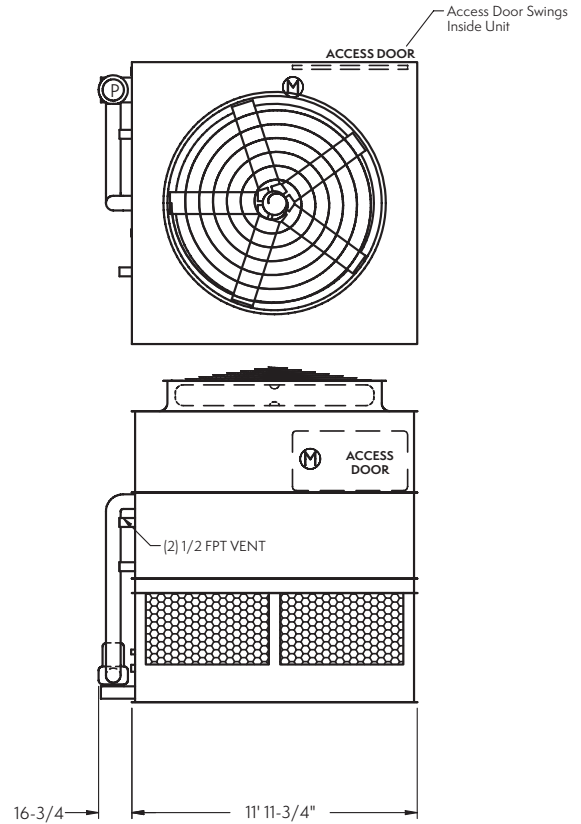
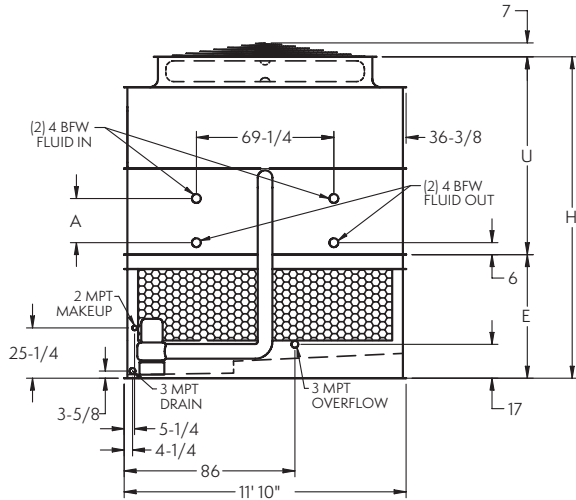

NOTE: The number of coil connections doubles when the flow rate exceeds 900 GPM on ATWB 12x12 models. This required option is referred to as the High Flow coil configuration.

ATWB Model Number†	Weights (lbs)			Fans		Spray Pump		Coil Volume (Gallons)	Remote Sump ▲			Dimensions ■			
	Shipping	Heaviest Section††	Operating	HP	CFM	HP	GPM		Gallons* Required	Conn. Size	Operating Weight (lbs)	Coil A	Upper U	Lower E	Height H
ATWB 12-3J12	14,250	11,540	22,870	15	72,500	5	800	312	490	12"	18,920	22-1/4"	8' 3-5/8"	5' 2-1/4"	13' 5-7/8"
ATWB 12-3K12	14,310	11,600	22,930	20	79,790	5	800	312	490	12"	18,980	22-1/4"	8' 3-5/8"	5' 2-1/4"	13' 5-7/8"
ATWB 12-3L12	14,340	11,630	22,960	25	85,040	5	800	312	490	12"	19,010	22-1/4"	8' 3-5/8"	5' 2-1/4"	13' 5-7/8"
ATWB 12-3M12	14,390	11,680	23,010	30	89,490	5	800	312	490	12"	19,060	22-1/4"	8' 3-5/8"	5' 2-1/4"	13' 5-7/8"
ATWB 12-4J12	16,560	13,850	26,000	15	70,390	5	800	409	490	12"	22,050	30-3/4"	9' 1/8"	5' 2-1/4"	14' 2-3/8"
ATWB 12-4K12	16,620	13,910	26,060	20	77,470	5	800	409	490	12"	22,110	30-3/4"	9' 1/8"	5' 2-1/4"	14' 2-3/8"
ATWB 12-4L12	16,650	13,940	26,090	25	82,560	5	800	409	490	12"	22,140	30-3/4"	9' 1/8"	5' 2-1/4"	14' 2-3/8"
ATWB 12-4M12	16,700	13,990	26,140	30	86,890	5	800	409	490	12"	22,190	30-3/4"	9' 1/8"	5' 2-1/4"	14' 2-3/8"
ATWB 12-4N12	16,860	14,150	26,300	40	94,180	5	800	409	490	12"	22,350	30-3/4"	9' 1/8"	5' 2-1/4"	14' 2-3/8"
ATWB 12-5K12	18,800	16,090	29,050	20	75,150	5	800	506	490	12"	25,100	39-1/4"	9' 8-5/8"	5' 2-1/4"	14' 10-7/8"
ATWB 12-5L12	18,830	16,120	29,080	25	80,090	5	800	506	490	12"	25,130	39-1/4"	9' 8-5/8"	5' 2-1/4"	14' 10-7/8"
ATWB 12-5M12	18,880	16,170	29,130	30	84,280	5	800	506	490	12"	25,180	39-1/4"	9' 8-5/8"	5' 2-1/4"	14' 10-7/8"
ATWB 12-5N12	19,040	16,330	29,290	40	91,350	5	800	506	490	12"	25,340	39-1/4"	9' 8-5/8"	5' 2-1/4"	14' 10-7/8"
ATWB 12-6L12	21,190	18,480	32,250	25	77,610	5	800	604	490	12"	28,300	47-3/4"	10' 5-1/8"	5' 2-1/4"	15' 7-3/8"
ATWB 12-6M12	21,240	18,530	32,300	30	81,670	5	800	604	490	12"	28,350	47-3/4"	10' 5-1/8"	5' 2-1/4"	15' 7-3/8"
ATWB 12-6N12	21,400	18,690	32,460	40	88,530	5	800	604	490	12"	28,510	47-3/4"	10' 5-1/8"	5' 2-1/4"	15' 7-3/8"
ATWB 12-7L12	23,810	21,100	35,690	25	75,130	5	800	701	490	12"	31,740	47-3/4"	10' 5-1/8"	5' 2-1/4"	15' 7-3/8"
ATWB 12-7M12	23,860	21,150	35,740	30	79,070	5	800	701	490	12"	31,790	47-3/4"	10' 5-1/8"	5' 2-1/4"	15' 7-3/8"
ATWB 12-7N12	24,020	21,310	35,900	40	85,700	5	800	701	490	12"	31,950	47-3/4"	10' 5-1/8"	5' 2-1/4"	15' 7-3/8"

† Model Numbers end in "-Z" for units with Series Flow piping configuration. Series Flow units may require additional coil connections and will require crossover piping. Model numbers will include "C" for units with Stainless Steel coil(s), "R" for units with Low Sound Fan(s) and "S" for units with an option that negates CTI certification.

†† Heaviest section is the coil/fan section.

\* Gallons shown is water in suspension in unit and piping. Allow for additional water in bottom of remote sump to cover pump suction and strainer during operation (12" would normally be sufficient).

▲ When a remote sump arrangement is selected, the spray pump, suction strainer and associated piping are omitted; the unit is provided with an oversized outlet to facilitate drainage to the remote sump.

■ Unit dimensions and coil connections may vary slightly from catalog. See factory certified prints for dimensions, quantity of coil connections, and piping configuration. Coil connections are 4" bevel for weld (BFW). Other connection types such as grooved for mechanical coupling or flanged are also available as options.



# ATWB 12-3K14 to 12-7N14

Selections for ATWB Closed Circuit Coolers are available from EVAPCO's **SPECTRUM™** Program. Please contact your local sales representative for more information on the **SPECTRUM™** program.

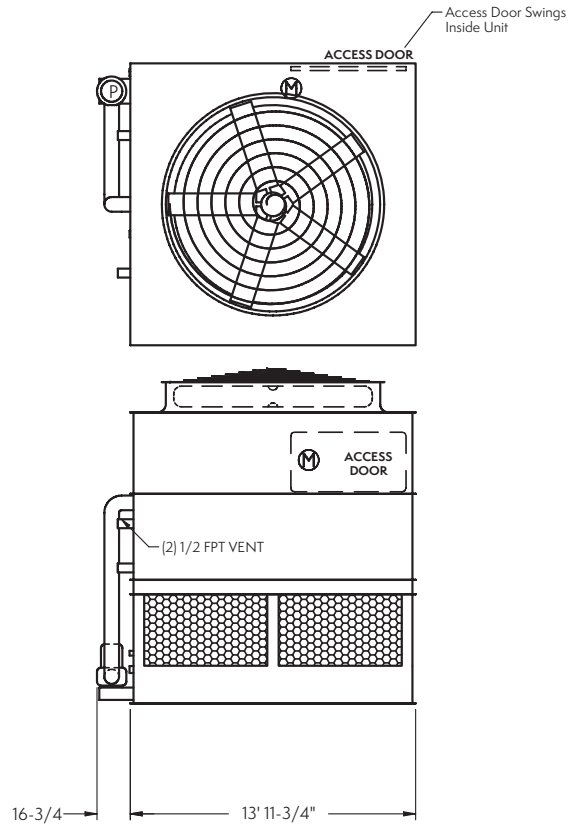
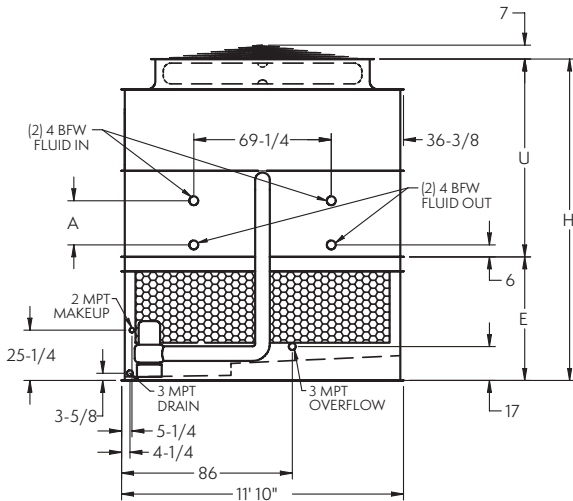

NOTE: The number of coil connections doubles when the flow rate exceeds 900 GPM on ATWB 12x14 models. This required option is referred to as the High Flow coil configuration.

ATWB Model Number†	Weights (lbs)			Fans		Spray Pump		Coil Volume (Gallons)	Remote Sump ▲			Dimensions ■			
	Shipping	Heaviest Section††	Operating	HP	CFM	HP	GPM		Gallons* Required	Conn. Size	Operating Weight (lbs)	Coil A	Upper U	Lower E	Height H
ATWB 12-3K14	16,170	13,110	26,290	20	88,450	5	900	361	570	12"	21,720	22-1/4"	8' 3-5/8"	5' 8-1/4"	13' 11-7/8"
ATWB 12-3L14	16,200	13,140	26,320	25	95,050	5	900	361	570	12"	21,750	22-1/4"	8' 3-5/8"	5' 8-1/4"	13' 11-7/8"
ATWB 12-3M14	16,250	13,190	26,370	30	100,020	5	900	361	570	12"	21,800	22-1/4"	8' 3-5/8"	5' 8-1/4"	13' 11-7/8"
ATWB 12-3N14	16,410	13,350	26,530	40	108,410	5	900	361	570	12"	21,960	22-1/4"	8' 3-5/8"	5' 8-1/4"	13' 11-7/8"
ATWB 12-4K14	18,860	15,800	29,930	20	85,870	5	900	475	570	12"	25,360	30-3/4"	9' 1/8"	5' 8-1/4"	14' 8-3/8"
ATWB 12-4L14	18,890	15,830	29,960	25	92,280	5	900	475	570	12"	25,390	30-3/4"	9' 1/8"	5' 8-1/4"	14' 8-3/8"
ATWB 12-4M14	18,940	15,880	30,010	30	97,110	5	900	475	570	12"	25,440	30-3/4"	9' 1/8"	5' 8-1/4"	14' 8-3/8"
ATWB 12-4N14	19,100	16,040	30,170	40	105,260	5	900	475	570	12"	25,600	30-3/4"	9' 1/8"	5' 8-1/4"	14' 8-3/8"
ATWB 12-5L14	21,390	18,330	33,410	25	89,510	5	900	589	570	12"	28,840	39-1/4"	9' 8-5/8"	5' 8-1/4"	15' 4-7/8"
ATWB 12-5M14	21,440	18,380	33,460	30	94,200	5	900	589	570	12"	28,890	39-1/4"	9' 8-5/8"	5' 8-1/4"	15' 4-7/8"
ATWB 12-5N14	21,600	18,540	33,620	40	102,100	5	900	589	570	12"	29,050	39-1/4"	9' 8-5/8"	5' 8-1/4"	15' 4-7/8"
ATWB 12-6L14	24,390	21,330	37,360	25	86,740	5	900	703	570	12"	32,790	47-3/4"	10' 5-1/8"	5' 8-1/4"	16' 1-3/8"
ATWB 12-6M14	24,440	21,380	37,410	30	91,280	5	900	703	570	12"	32,840	47-3/4"	10' 5-1/8"	5' 8-1/4"	16' 1-3/8"
ATWB 12-6N14	24,600	21,540	37,570	40	98,940	5	900	703	570	12"	33,000	47-3/4"	10' 5-1/8"	5' 8-1/4"	16' 1-3/8"
ATWB 12-7L14	27,490	24,430	41,410	25	83,970	5	900	817	570	12"	36,840	47-3/4"	10' 5-1/8"	5' 8-1/4"	16' 1-3/8"
ATWB 12-7M14	27,540	24,480	41,460	30	88,370	5	900	817	570	12"	36,890	47-3/4"	10' 5-1/8"	5' 8-1/4"	16' 1-3/8"
ATWB 12-7N14	27,700	24,640	41,620	40	95,780	5	900	817	570	12"	37,050	47-3/4"	10' 5-1/8"	5' 8-1/4"	16' 1-3/8"

† Model Numbers end in "-Z" for units with Series Flow piping configuration. Series Flow units may require additional coil connections and will require crossover piping. Model numbers will include "C" for units with Stainless Steel coil(s), "R" for units with Low Sound Fan(s) and "S" for units with an option that negates CTI certification.

†† Heaviest section is the coil/fan section.

\* Gallons shown is water in suspension in unit and piping. Allow for additional water in bottom of remote sump to cover pump suction and strainer during operation (12" would normally be sufficient).

▲ When a remote sump arrangement is selected, the spray pump, suction strainer and associated piping are omitted; the unit is provided with an oversized outlet to facilitate drainage to the remote sump.

■ Unit dimensions and coil connections may vary slightly from catalog. See factory certified prints for dimensions, quantity of coil connections, and piping configuration. Coil connections are 4" bevel for weld (BFW). Other connection types such as grooved for mechanical coupling or flanged are also available as options.

# ATWB 12-3K18 to 12-7P18

Selections for ATWB Closed Circuit Coolers are available from EVAPCO's **SPECTRUM™** Program. Please contact your local sales representative for more information on the **SPECTRUM™** program.

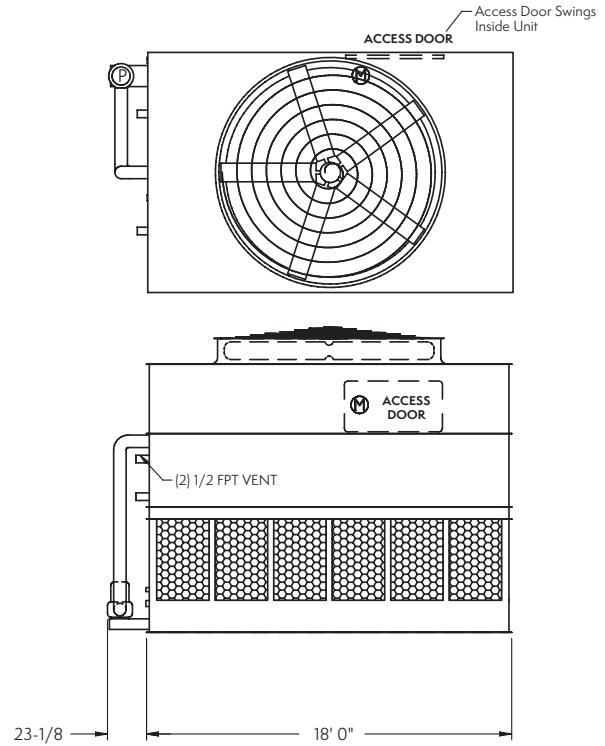
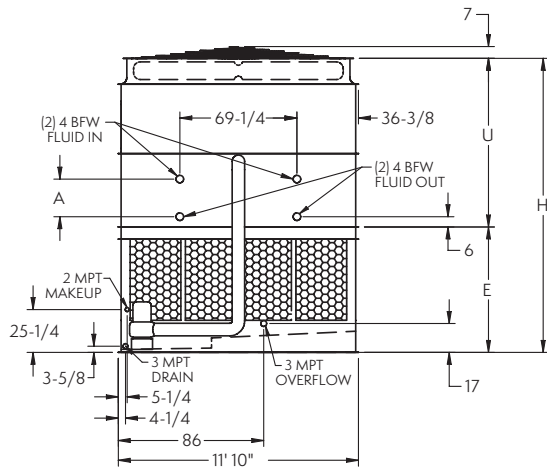

NOTE: The number of coil connections doubles when the flow rate exceeds 900 GPM on ATWB 12x18 models. This required option is referred to as the High Flow coil configuration.

ATWB Model Number†	Weights (lbs)			Fans		Spray Pump		Coil Volume (Gallons)	Remote Sump <sup>△</sup>			Dimensions <sup>■</sup>			
	Shipping	Heaviest Section††	Operating	HP	CFM	HP	GPM		Gallons* Required	Conn. Size	Operating Weight (lbs)	Coil A	Upper U	Lower E	Height H
ATWB 12-3K18	20,260	16,340	33,200	20	108,040	7.5	1,200	461	720	12"	27,330	22-1/4"	8' 3-5/8"	6' 2-1/4"	14' 5-7/8"
ATWB 12-3L18	20,290	16,370	33,230	25	116,380	7.5	1,200	461	720	12"	27,360	22-1/4"	8' 3-5/8"	6' 2-1/4"	14' 5-7/8"
ATWB 12-3M18	20,340	16,420	33,280	30	123,680	7.5	1,200	461	720	12"	27,410	22-1/4"	8' 3-5/8"	6' 2-1/4"	14' 5-7/8"
ATWB 12-3N18	20,500	16,580	33,440	40	134,230	7.5	1,200	461	720	12"	27,570	22-1/4"	8' 3-5/8"	6' 2-1/4"	14' 5-7/8"
ATWB 12-4K18	23,690	19,770	37,860	20	104,900	7.5	1,200	608	720	12"	31,990	30-3/4"	9' 1/8"	6' 2-1/4"	15' 2-3/8"
ATWB 12-4L18	23,720	19,800	37,890	25	112,990	7.5	1,200	608	720	12"	32,020	30-3/4"	9' 1/8"	6' 2-1/4"	15' 2-3/8"
ATWB 12-4M18	23,770	19,850	37,940	30	120,070	7.5	1,200	608	720	12"	32,070	30-3/4"	9' 1/8"	6' 2-1/4"	15' 2-3/8"
ATWB 12-4N18	23,930	20,010	38,100	40	130,320	7.5	1,200	608	720	12"	32,230	30-3/4"	9' 1/8"	6' 2-1/4"	15' 2-3/8"
ATWB 12-4O18	23,940	20,020	38,110	50	138,720	7.5	1,200	608	720	12"	32,240	30-3/4"	9' 1/8"	6' 2-1/4"	15' 2-3/8"
ATWB 12-5L18	27,020	23,100	42,410	25	109,600	7.5	1,200	755	720	12"	36,540	39-1/4"	9' 8-5/8"	6' 2-1/4"	15' 10-7/8"
ATWB 12-5M18	27,070	23,150	42,460	30	116,470	7.5	1,200	755	720	12"	36,590	39-1/4"	9' 8-5/8"	6' 2-1/4"	15' 10-7/8"
ATWB 12-5N18	27,230	23,310	42,620	40	126,410	7.5	1,200	755	720	12"	36,750	39-1/4"	9' 8-5/8"	6' 2-1/4"	15' 10-7/8"
ATWB 12-5O18	27,240	23,320	42,630	50	134,560	7.5	1,200	755	720	12"	36,760	39-1/4"	9' 8-5/8"	6' 2-1/4"	15' 10-7/8"
ATWB 12-6M18	30,460	26,540	47,080	30	112,870	7.5	1,200	902	720	12"	41,210	47-3/4"	10' 5-1/8"	6' 2-1/4"	16' 7-3/8"
ATWB 12-6N18	30,620	26,700	47,240	40	122,500	7.5	1,200	902	720	12"	41,370	47-3/4"	10' 5-1/8"	6' 2-1/4"	16' 7-3/8"
ATWB 12-6O18	30,630	26,710	47,250	50	130,390	7.5	1,200	902	720	12"	41,380	47-3/4"	10' 5-1/8"	6' 2-1/4"	16' 7-3/8"
ATWB 12-6P18	30,830	26,910	47,450	60	137,220	7.5	1,200	902	720	12"	41,580	47-3/4"	10' 5-1/8"	6' 2-1/4"	16' 7-3/8"
ATWB 12-7M18	34,380	30,460	52,230	30	109,270	7.5	1,200	1,050	720	12"	46,360	47-3/4"	10' 5-1/8"	6' 2-1/4"	16' 7-3/8"
ATWB 12-7N18	34,540	30,620	52,390	40	118,590	7.5	1,200	1,050	720	12"	46,520	47-3/4"	10' 5-1/8"	6' 2-1/4"	16' 7-3/8"
ATWB 12-7O18	34,550	30,630	52,400	50	126,230	7.5	1,200	1,050	720	12"	46,530	47-3/4"	10' 5-1/8"	6' 2-1/4"	16' 7-3/8"
ATWB 12-7P18	34,750	30,830	52,600	60	132,840	7.5	1,200	1,050	720	12"	46,730	47-3/4"	10' 5-1/8"	6' 2-1/4"	16' 7-3/8"

† Model Numbers end in "-Z" for units with Series Flow piping configuration. Series Flow units may require additional coil connections and will require crossover piping. Model numbers will include "C" for units with Stainless Steel coil(s), "R" for units with Low Sound Fan(s) and "S" for units with an option that negates CTI certification.

†† Heaviest section is the coil/fan section.

\* Gallons shown is water in suspension in unit and piping. Allow for additional water in bottom of remote sump to cover pump suction and strainer during operation (12" would normally be sufficient).

△ When a remote sump arrangement is selected, the spray pump, suction strainer and associated piping are omitted; the unit is provided with an oversized outlet to facilitate drainage to the remote sump.

■ Unit dimensions and coil connections may vary slightly from catalog. See factory certified prints for dimensions, quantity of coil connections, and piping configuration. Coil connections are 4" bevel for weld (BFW). Other connection types such as grooved for mechanical coupling or flanged are also available as options.

# ATWB 12-3L20 to 12-7P20

Selections for ATWB Closed Circuit Coolers are available from EVAPCO's **SPECTRUM™** Program. Please contact your local sales representative for more information on the **SPECTRUM™** program.

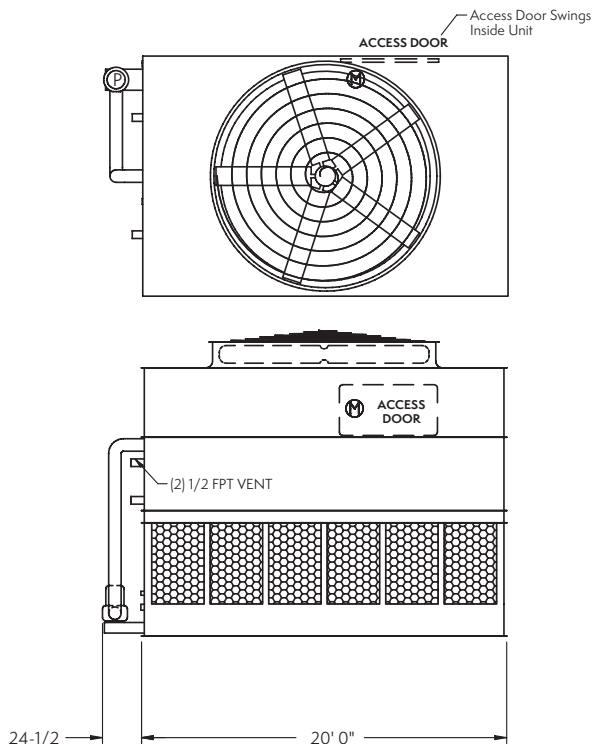
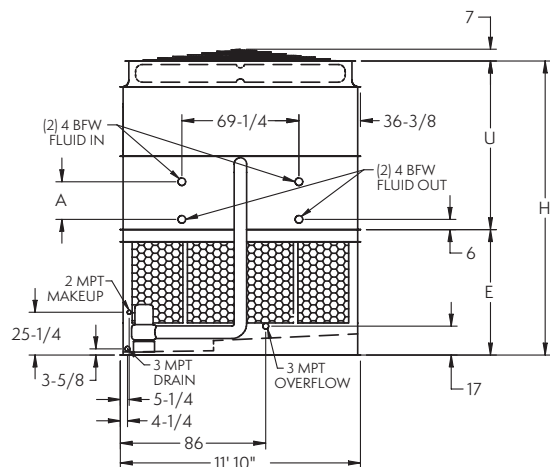

NOTE: The number of coil connections doubles when the flow rate exceeds 900 GPM on ATWB 12x20 models. This required option is referred to as the High Flow coil configuration.

ATWB Model Number†	Weights (lbs)			Fans		Spray Pump		Coil Volume (Gallons)	Remote Sump ▲			Dimensions ■			
	Shipping	Heaviest Section††	Operating	HP	CFM	HP	GPM		Gallons* <sup>2</sup> Required	Conn. Size	Operating Weight (lbs)	Coil A	Upper U	Lower E	Height H
ATWB 12-3L20	22,360	17,850	36,830	25	124,860	10	1,400	511	800	14"	30,130	22-1/4"	8' 3-5/8"	6' 2-1/4"	14' 5-7/8"
ATWB 12-3M20	22,410	17,900	36,880	30	132,680	10	1,400	511	800	14"	30,180	22-1/4"	8' 3-5/8"	6' 2-1/4"	14' 5-7/8"
ATWB 12-3N20	22,570	18,060	37,040	40	144,810	10	1,400	511	800	14"	30,340	22-1/4"	8' 3-5/8"	6' 2-1/4"	14' 5-7/8"
ATWB 12-3O20	22,580	18,070	37,050	50	154,150	10	1,400	511	800	14"	30,350	22-1/4"	8' 3-5/8"	6' 2-1/4"	14' 5-7/8"
ATWB 12-4L20	26,140	21,630	41,980	25	121,220	10	1,400	674	800	14"	35,280	30-3/4"	9' 1/8"	6' 2-1/4"	15' 2-3/8"
ATWB 12-4M20	26,190	21,680	42,030	30	128,820	10	1,400	674	800	14"	35,330	30-3/4"	9' 1/8"	6' 2-1/4"	15' 2-3/8"
ATWB 12-4N20	26,350	21,840	42,190	40	140,590	10	1,400	674	800	14"	35,490	30-3/4"	9' 1/8"	6' 2-1/4"	15' 2-3/8"
ATWB 12-4O20	26,360	21,850	42,200	50	149,660	10	1,400	674	800	14"	35,500	30-3/4"	9' 1/8"	6' 2-1/4"	15' 2-3/8"
ATWB 12-5M20	29,870	25,360	47,080	30	124,950	10	1,400	838	800	14"	40,380	39-1/4"	9' 8-5/8"	6' 2-1/4"	15' 10-7/8"
ATWB 12-5N20	30,030	25,520	47,240	40	136,380	10	1,400	838	800	14"	40,540	39-1/4"	9' 8-5/8"	6' 2-1/4"	15' 10-7/8"
ATWB 12-5O20	30,040	25,530	47,250	50	145,170	10	1,400	838	800	14"	40,550	39-1/4"	9' 8-5/8"	6' 2-1/4"	15' 10-7/8"
ATWB 12-5P20	30,240	25,730	47,450	60	152,770	10	1,400	838	800	14"	40,750	39-1/4"	9' 8-5/8"	6' 2-1/4"	15' 10-7/8"
ATWB 12-6N20	34,180	29,670	52,750	40	132,160	10	1,400	1,002	800	14"	46,050	47-3/4"	10' 5-1/8"	6' 2-1/4"	16' 7-3/8"
ATWB 12-6O20	34,190	29,680	52,760	50	140,680	10	1,400	1,002	800	14"	46,060	47-3/4"	10' 5-1/8"	6' 2-1/4"	16' 7-3/8"
ATWB 12-6P20	34,390	29,880	52,960	60	148,050	10	1,400	1,002	800	14"	46,260	47-3/4"	10' 5-1/8"	6' 2-1/4"	16' 7-3/8"
ATWB 12-7N20	38,610	34,100	58,550	40	127,940	10	1,400	1,166	800	14"	51,850	47-3/4"	10' 5-1/8"	6' 2-1/4"	16' 7-3/8"
ATWB 12-7O20	38,620	34,110	58,560	50	136,190	10	1,400	1,166	800	14"	51,860	47-3/4"	10' 5-1/8"	6' 2-1/4"	16' 7-3/8"
ATWB 12-7P20	38,820	34,310	58,760	60	143,320	10	1,400	1,166	800	14"	52,060	47-3/4"	10' 5-1/8"	6' 2-1/4"	16' 7-3/8"

† Model Numbers end in "-Z" for units with Series Flow piping configuration. Series Flow units may require additional coil connections and will require crossover piping. Model numbers will include "C" for units with Stainless Steel coil(s), "R" for units with Low Sound Fan(s) and "S" for units with an option that negates CTI certification.

†† Heaviest section is the coil/fan section.

\* Gallons shown is water in suspension in unit and piping. Allow for additional water in bottom of remote sump to cover pump suction and strainer during operation (12" would normally be sufficient).

▲ When a remote sump arrangement is selected, the spray pump, suction strainer and associated piping are omitted; the unit is provided with an oversized outlet to facilitate drainage to the remote sump.

■ Unit dimensions and coil connections may vary slightly from catalog. See factory certified prints for dimensions, quantity of coil connections, and piping configuration. Coil connections are 4" bevel for weld (BFW). Other connection types such as grooved for mechanical coupling or flanged are also available as options.

# ATWB 12-3J24 to 12-7N24

Selections for ATWB Closed Circuit Coolers are available from EVAPCO's **SPECTRUM™** Program. Please contact your local sales representative for more information on the **SPECTRUM™** program.

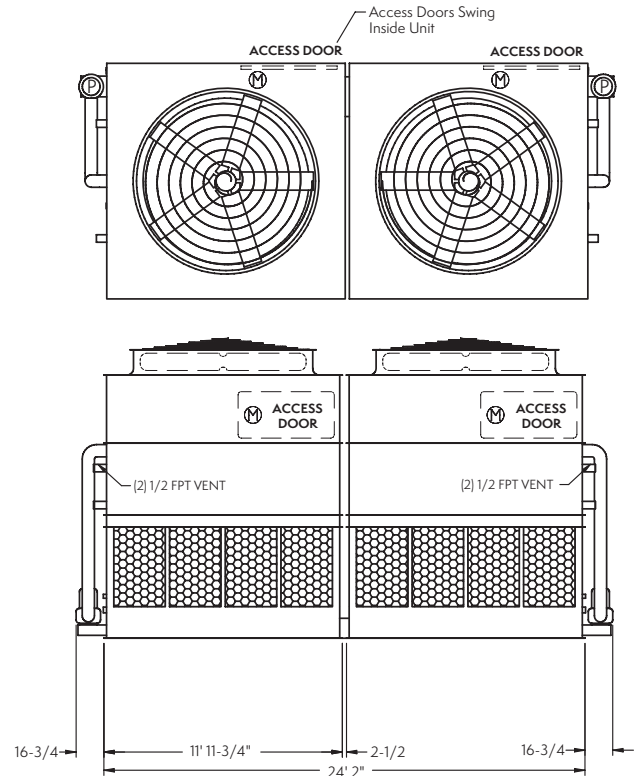
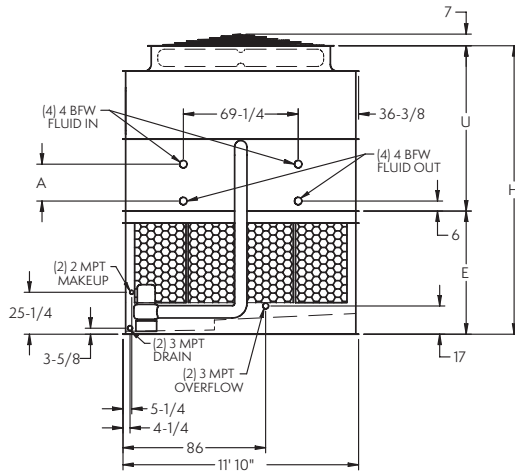

**NOTE:** The number of coil connections doubles when the flow rate exceeds 1,800 GPM on ATWB 12x24 models. This required option is referred to as the High Flow coil configuration.

ATWB Model Number†	Weights (lbs)			Fans		Spray Pump		Coil Volume (Gallons)	Remote Sump Δ			Dimensions ■			
	Shipping	Heaviest Section††	Operating	HP	CFM	HP	GPM		Gallons* Required	Conn. Size	Operating Weight (lbs)	Coil A	Upper U	Lower E	Height H
ATWB 12-3J24	28,500	11,540	45,740	(2) 15	145,000	(2) 5	1,600	623	980	(2) 12"	37,840	22-1/4"	8' 3-5/8"	6' 2-1/4"	14' 5-7/8"
ATWB 12-3K24	28,620	11,600	45,860	(2) 20	159,590	(2) 5	1,600	623	980	(2) 12"	37,960	22-1/4"	8' 3-5/8"	6' 2-1/4"	14' 5-7/8"
ATWB 12-3L24	28,680	11,630	45,920	(2) 25	170,080	(2) 5	1,600	623	980	(2) 12"	38,020	22-1/4"	8' 3-5/8"	6' 2-1/4"	14' 5-7/8"
ATWB 12-3M24	28,780	11,680	46,020	(2) 30	178,990	(2) 5	1,600	623	980	(2) 12"	38,120	22-1/4"	8' 3-5/8"	6' 2-1/4"	14' 5-7/8"
ATWB 12-4K24	33,240	13,910	52,120	(2) 20	154,940	(2) 5	1,600	818	980	(2) 12"	44,220	30-3/4"	9' 1/8"	6' 2-1/4"	15' 2-3/8"
ATWB 12-4L24	33,300	13,940	52,180	(2) 25	165,130	(2) 5	1,600	818	980	(2) 12"	44,280	30-3/4"	9' 1/8"	6' 2-1/4"	15' 2-3/8"
ATWB 12-4M24	33,400	13,990	52,280	(2) 30	173,780	(2) 5	1,600	818	980	(2) 12"	44,380	30-3/4"	9' 1/8"	6' 2-1/4"	15' 2-3/8"
ATWB 12-4N24	33,720	14,150	52,600	(2) 40	188,350	(2) 5	1,600	818	980	(2) 12"	44,700	30-3/4"	9' 1/8"	6' 2-1/4"	15' 2-3/8"
ATWB 12-5K24	37,600	16,090	58,100	(2) 20	150,290	(2) 5	1,600	1,013	980	(2) 12"	50,200	39-1/4"	9' 8-5/8"	6' 2-1/4"	15' 10-7/8"
ATWB 12-5L24	37,660	16,120	58,160	(2) 25	160,170	(2) 5	1,600	1,013	980	(2) 12"	50,260	39-1/4"	9' 8-5/8"	6' 2-1/4"	15' 10-7/8"
ATWB 12-5M24	37,760	16,170	58,260	(2) 30	168,560	(2) 5	1,600	1,013	980	(2) 12"	50,360	39-1/4"	9' 8-5/8"	6' 2-1/4"	15' 10-7/8"
ATWB 12-5N24	38,080	16,330	58,580	(2) 40	182,700	(2) 5	1,600	1,013	980	(2) 12"	50,680	39-1/4"	9' 8-5/8"	6' 2-1/4"	15' 10-7/8"
ATWB 12-6L24	42,380	18,480	64,500	(2) 25	155,220	(2) 5	1,600	1,208	980	(2) 12"	56,600	47-3/4"	10' 5-1/8"	6' 2-1/4"	16' 7-3/8"
ATWB 12-6M24	42,480	18,530	64,600	(2) 30	163,350	(2) 5	1,600	1,208	980	(2) 12"	56,700	47-3/4"	10' 5-1/8"	6' 2-1/4"	16' 7-3/8"
ATWB 12-6N24	42,800	18,690	64,920	(2) 40	177,050	(2) 5	1,600	1,208	980	(2) 12"	57,020	47-3/4"	10' 5-1/8"	6' 2-1/4"	16' 7-3/8"
ATWB 12-7L24	47,620	21,100	71,380	(2) 25	150,270	(2) 5	1,600	1,403	980	(2) 12"	63,480	47-3/4"	10' 5-1/8"	6' 2-1/4"	16' 7-3/8"
ATWB 12-7M24	47,720	21,150	71,480	(2) 30	158,140	(2) 5	1,600	1,403	980	(2) 12"	63,580	47-3/4"	10' 5-1/8"	6' 2-1/4"	16' 7-3/8"
ATWB 12-7N24	48,040	21,310	71,800	(2) 40	171,400	(2) 5	1,600	1,403	980	(2) 12"	63,900	47-3/4"	10' 5-1/8"	6' 2-1/4"	16' 7-3/8"

† Model Numbers end in "-Z" for units with Series Flow piping configuration. Series Flow units may require additional coil connections and will require crossover piping. Model numbers will include "C" for units with Stainless Steel coil(s), "R" for units with Low Sound Fan(s) and "S" for units with an option that negates CTI certification.

†† Heaviest section is the coil/fan section.

\* Gallons shown is water in suspension in unit and piping. Allow for additional water in bottom of remote sump to cover pump suction and strainer during operation (12" would normally be sufficient).

Δ When a remote sump arrangement is selected, the spray pump, suction strainer and associated piping are omitted; the unit is provided with an oversized outlet to facilitate drainage to the remote sump.

■ Unit dimensions and coil connections may vary slightly from catalog. See factory certified prints for dimensions, quantity of coil connections, and piping configuration. Coil connections are 4" bevel for weld (BFW). Other connection types such as grooved for mechanical coupling or flanged are also available as options.



# ATWB 12-3K28 to 12-7N28

Selections for ATWB Closed Circuit Coolers are available from EVAPCO's **SPECTRUM™** Program. Please contact your local sales representative for more information on the **SPECTRUM™** program.

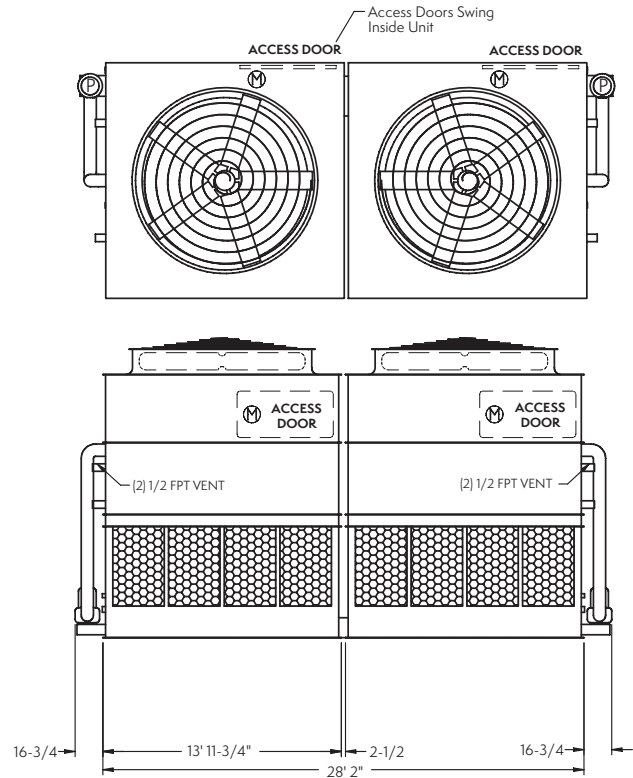
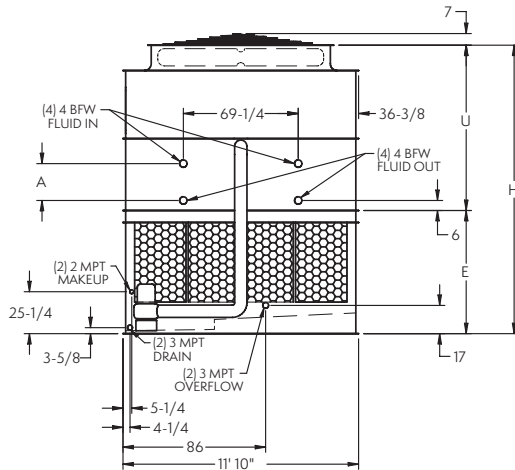

**NOTE:** The number of coil connections doubles when the flow rate exceeds 1,800 GPM on ATWB 12x28 models. This required option is referred to as the High Flow coil configuration.

ATWB Model Number†	Weights (lbs)			Fans		Spray Pump		Coil Volume (Gallons)	Remote Sump <sup>△</sup>			Dimensions <sup>■</sup>			
	Shipping	Heaviest Section††	Operating	HP	CFM	HP	GPM		Gallons* Required	Conn. Size	Operating Weight (lbs)	Coil A	Upper U	Lower E	Height H
ATWB 12-3K28	32,340	13,110	52,580	(2) 20	176,900	(2) 5	1,800	723	1,140	(2) 12"	43,440	22-1/4"	8' 3-5/8"	7' 2-1/4"	15' 5-7/8"
ATWB 12-3L28	32,400	13,140	52,640	(2) 25	190,090	(2) 5	1,800	723	1,140	(2) 12"	43,500	22-1/4"	8' 3-5/8"	7' 2-1/4"	15' 5-7/8"
ATWB 12-3M28	32,500	13,190	52,740	(2) 30	200,050	(2) 5	1,800	723	1,140	(2) 12"	43,600	22-1/4"	8' 3-5/8"	7' 2-1/4"	15' 5-7/8"
ATWB 12-3N28	32,820	13,350	53,060	(2) 40	216,830	(2) 5	1,800	723	1,140	(2) 12"	43,920	22-1/4"	8' 3-5/8"	7' 2-1/4"	15' 5-7/8"
ATWB 12-4K28	37,720	15,800	59,860	(2) 20	171,750	(2) 5	1,800	951	1,140	(2) 12"	50,720	30-3/4"	9' 1/8"	7' 2-1/4"	16' 2-3/8"
ATWB 12-4L28	37,780	15,830	59,920	(2) 25	184,560	(2) 5	1,800	951	1,140	(2) 12"	50,780	30-3/4"	9' 1/8"	7' 2-1/4"	16' 2-3/8"
ATWB 12-4M28	37,880	15,880	60,020	(2) 30	194,220	(2) 5	1,800	951	1,140	(2) 12"	50,880	30-3/4"	9' 1/8"	7' 2-1/4"	16' 2-3/8"
ATWB 12-4N28	38,200	16,040	60,340	(2) 40	210,510	(2) 5	1,800	951	1,140	(2) 12"	51,200	30-3/4"	9' 1/8"	7' 2-1/4"	16' 2-3/8"
ATWB 12-5L28	42,780	18,330	66,820	(2) 25	179,020	(2) 5	1,800	1,179	1,140	(2) 12"	57,680	39-1/4"	9' 8-5/8"	7' 2-1/4"	16' 10-7/8"
ATWB 12-5M28	42,880	18,380	66,920	(2) 30	188,400	(2) 5	1,800	1,179	1,140	(2) 12"	57,780	39-1/4"	9' 8-5/8"	7' 2-1/4"	16' 10-7/8"
ATWB 12-5N28	43,200	18,540	67,240	(2) 40	204,200	(2) 5	1,800	1,179	1,140	(2) 12"	58,100	39-1/4"	9' 8-5/8"	7' 2-1/4"	16' 10-7/8"
ATWB 12-6L28	48,780	21,330	74,720	(2) 25	173,480	(2) 5	1,800	1,407	1,140	(2) 12"	65,580	47-3/4"	10' 5-1/8"	7' 2-1/4"	17' 7-3/8"
ATWB 12-6M28	48,880	21,380	74,820	(2) 30	182,570	(2) 5	1,800	1,407	1,140	(2) 12"	65,680	47-3/4"	10' 5-1/8"	7' 2-1/4"	17' 7-3/8"
ATWB 12-6N28	49,200	21,540	75,140	(2) 40	197,880	(2) 5	1,800	1,407	1,140	(2) 12"	66,000	47-3/4"	10' 5-1/8"	7' 2-1/4"	17' 7-3/8"
ATWB 12-7L28	54,980	24,430	82,820	(2) 25	167,950	(2) 5	1,800	1,635	1,140	(2) 12"	73,680	47-3/4"	10' 5-1/8"	7' 2-1/4"	17' 7-3/8"
ATWB 12-7M28	55,080	24,480	82,920	(2) 30	176,740	(2) 5	1,800	1,635	1,140	(2) 12"	73,780	47-3/4"	10' 5-1/8"	7' 2-1/4"	17' 7-3/8"
ATWB 12-7N28	55,400	24,640	83,240	(2) 40	191,570	(2) 5	1,800	1,635	1,140	(2) 12"	74,100	47-3/4"	10' 5-1/8"	7' 2-1/4"	17' 7-3/8"

† Model Numbers end in "-Z" for units with Series Flow piping configuration. Series Flow units may require additional coil connections and will require crossover piping. Model numbers will include "C" for units with Stainless Steel coil(s), "R" for units with Low Sound Fan(s) and "S" for units with an option that negates CTI certification.

†† Heaviest section is the coil/fan section.

\* Gallons shown is water in suspension in unit and piping. Allow for additional water in bottom of remote sump to cover pump suction and strainer during operation (12" would normally be sufficient).

△ When a remote sump arrangement is selected, the spray pump, suction strainer and associated piping are omitted; the unit is provided with an oversized outlet to facilitate drainage to the remote sump.

■ Unit dimensions and coil connections may vary slightly from catalog. See factory certified prints for dimensions, quantity of coil connections, and piping configuration. Coil connections are 4" bevel for weld (BFW). Other connection types such as grooved for mechanical coupling or flanged are also available as options.

# ATWB 12-3K36 to 12-7P36

Selections for ATWB Closed Circuit Coolers are available from EVAPCO's **SPECTRUM™** Program. Please contact your local sales representative for more information on the **SPECTRUM™** program.

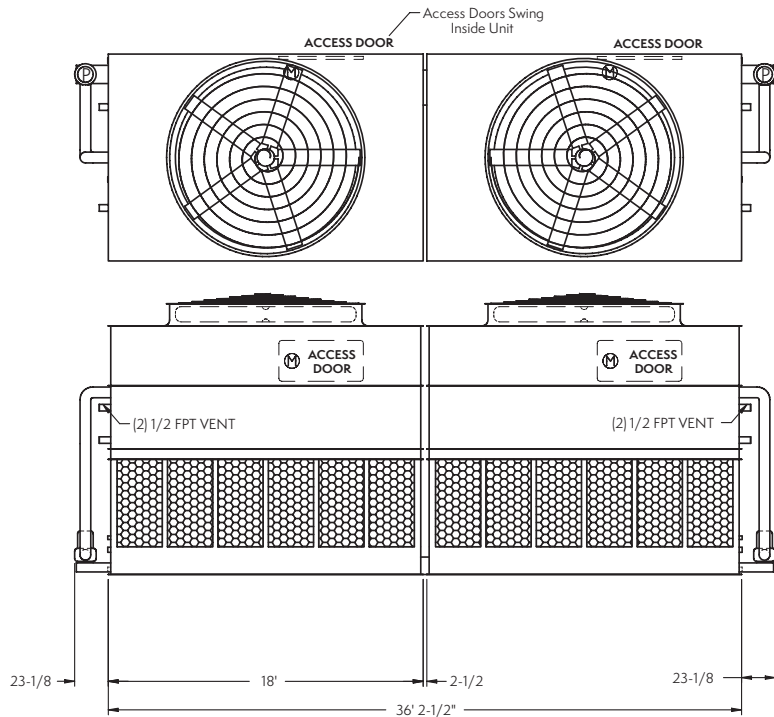
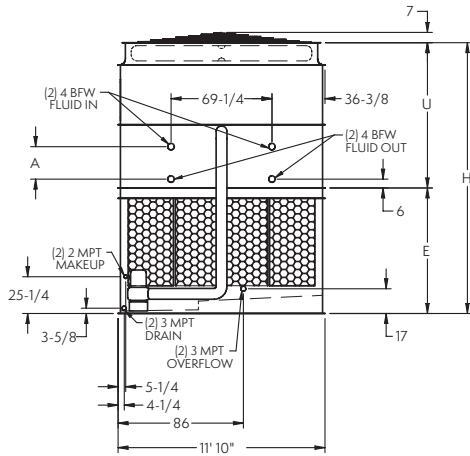

NOTE: The number of coil connections doubles when the flow rate exceeds 1,800 GPM on ATWB 12x36 models. This required option is referred to as the High Flow coil configuration.

ATWB Model Number†	Weights (lbs)			Fans		Spray Pump		Coil Volume (Gallons)	Remote Sump <sup>△</sup>			Dimensions <sup>■</sup>			
	Shipping	Heaviest Section††	Operating	HP	CFM	HP	GPM		Gallons* Required	Conn. Size	Operating Weight (lbs)	Coil A	Upper U	Lower E	Height H
ATWB 12-3K36	40,520	16,340	66,400	[2] 20	216,080	[2] 7.5	2,400	922	1,440	[2] 12"	54,660	22-1/4"	8' 3-5/8"	7' 2-1/4"	15' 5-7/8"
ATWB 12-3L36	40,580	16,370	66,460	[2] 25	232,770	[2] 7.5	2,400	922	1,440	[2] 12"	54,720	22-1/4"	8' 3-5/8"	7' 2-1/4"	15' 5-7/8"
ATWB 12-3M36	40,680	16,420	66,560	[2] 30	247,350	[2] 7.5	2,400	922	1,440	[2] 12"	54,820	22-1/4"	8' 3-5/8"	7' 2-1/4"	15' 5-7/8"
ATWB 12-3N36	41,000	16,580	66,880	[2] 40	268,450	[2] 7.5	2,400	922	1,440	[2] 12"	55,140	22-1/4"	8' 3-5/8"	7' 2-1/4"	15' 5-7/8"
ATWB 12-4K36	47,380	19,770	75,720	[2] 20	209,790	[2] 7.5	2,400	1,216	1,440	[2] 12"	63,980	30-3/4"	9' 1/8"	7' 2-1/4"	16' 2-3/8"
ATWB 12-4L36	47,440	19,800	75,780	[2] 25	225,990	[2] 7.5	2,400	1,216	1,440	[2] 12"	64,040	30-3/4"	9' 1/8"	7' 2-1/4"	16' 2-3/8"
ATWB 12-4M36	47,540	19,850	75,880	[2] 30	240,150	[2] 7.5	2,400	1,216	1,440	[2] 12"	64,140	30-3/4"	9' 1/8"	7' 2-1/4"	16' 2-3/8"
ATWB 12-4N36	47,860	20,010	76,200	[2] 40	260,630	[2] 7.5	2,400	1,216	1,440	[2] 12"	64,460	30-3/4"	9' 1/8"	7' 2-1/4"	16' 2-3/8"
ATWB 12-4O36	47,880	20,020	76,220	[2] 50	277,440	[2] 7.5	2,400	1,216	1,440	[2] 12"	64,480	30-3/4"	9' 1/8"	7' 2-1/4"	16' 2-3/8"
ATWB 12-5L36	54,040	23,100	84,820	[2] 25	219,210	[2] 7.5	2,400	1,510	1,440	[2] 12"	73,080	39-1/4"	9' 8-5/8"	7' 2-1/4"	16' 10-7/8"
ATWB 12-5M36	54,140	23,150	84,920	[2] 30	232,940	[2] 7.5	2,400	1,510	1,440	[2] 12"	73,180	39-1/4"	9' 8-5/8"	7' 2-1/4"	16' 10-7/8"
ATWB 12-5N36	54,460	23,310	85,240	[2] 40	252,810	[2] 7.5	2,400	1,510	1,440	[2] 12"	73,500	39-1/4"	9' 8-5/8"	7' 2-1/4"	16' 10-7/8"
ATWB 12-5O36	54,480	23,320	85,260	[2] 50	269,110	[2] 7.5	2,400	1,510	1,440	[2] 12"	73,520	39-1/4"	9' 8-5/8"	7' 2-1/4"	16' 10-7/8"
ATWB 12-6M36	60,920	26,540	94,160	[2] 30	225,740	[2] 7.5	2,400	1,805	1,440	[2] 12"	82,420	47-3/4"	10' 5-1/8"	7' 2-1/4"	17' 7-3/8"
ATWB 12-6N36	61,240	26,700	94,480	[2] 40	244,990	[2] 7.5	2,400	1,805	1,440	[2] 12"	82,740	47-3/4"	10' 5-1/8"	7' 2-1/4"	17' 7-3/8"
ATWB 12-6O36	61,260	26,710	94,500	[2] 50	260,790	[2] 7.5	2,400	1,805	1,440	[2] 12"	82,760	47-3/4"	10' 5-1/8"	7' 2-1/4"	17' 7-3/8"
ATWB 12-6P36	61,660	26,910	94,900	[2] 60	274,450	[2] 7.5	2,400	1,805	1,440	[2] 12"	83,160	47-3/4"	10' 5-1/8"	7' 2-1/4"	17' 7-3/8"
ATWB 12-7M36	68,760	30,460	104,460	[2] 30	218,530	[2] 7.5	2,400	2,099	1,440	[2] 12"	92,720	47-3/4"	10' 5-1/8"	7' 2-1/4"	17' 7-3/8"
ATWB 12-7N36	69,080	30,620	104,780	[2] 40	237,170	[2] 7.5	2,400	2,099	1,440	[2] 12"	93,040	47-3/4"	10' 5-1/8"	7' 2-1/4"	17' 7-3/8"
ATWB 12-7O36	69,100	30,630	104,800	[2] 50	252,470	[2] 7.5	2,400	2,099	1,440	[2] 12"	93,060	47-3/4"	10' 5-1/8"	7' 2-1/4"	17' 7-3/8"
ATWB 12-7P36	69,500	30,830	105,200	[2] 60	265,690	[2] 7.5	2,400	2,099	1,440	[2] 12"	93,460	47-3/4"	10' 5-1/8"	7' 2-1/4"	17' 7-3/8"

† Model Numbers end in "-Z" for units with Series Flow piping configuration. Series Flow units may require additional coil connections and will require crossover piping. Model numbers will include "C" for units with Stainless Steel coil(s), "R" for units with Low Sound Fan(s) and "S" for units with an option that negates CTI certification.

†† Heaviest section is the coil/fan section.

\* Gallons shown is water in suspension in unit and piping. Allow for additional water in bottom of remote sump to cover pump suction and strainer during operation (12" would normally be sufficient).

△ When a remote sump arrangement is selected, the spray pump, suction strainer and associated piping are omitted; the unit is provided with an oversized outlet to facilitate drainage to the remote sump.

■ Unit dimensions and coil connections may vary slightly from catalog. See factory certified prints for dimensions, quantity of coil connections, and piping configuration. Coil connections are 4" bevel for weld (BFW). Other connection types such as grooved for mechanical coupling or flanged are also available as options.

# ATWB 12-3L40 to 12-7P40

Selections for ATWB Closed Circuit Coolers are available from EVAPCO's SPECTRUM™ Program. Please contact your local sales representative for more information on the SPECTRUM™ program.

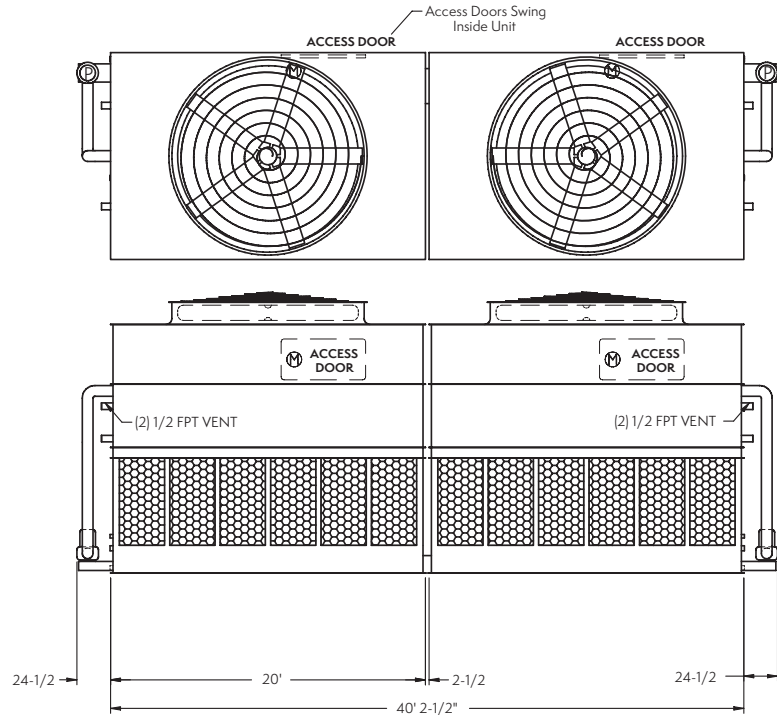
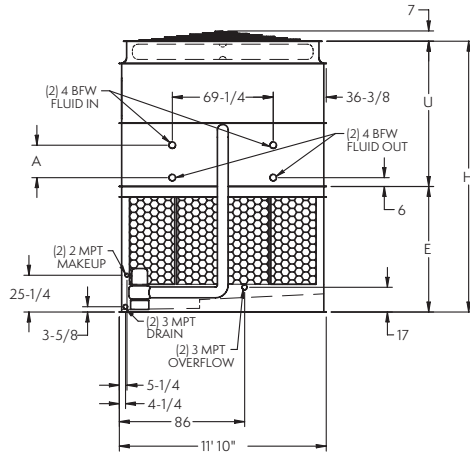

NOTE: The number of coil connections doubles when the flow rate exceeds 1,800 GPM on ATWB 12x40 models. This required option is referred to as the High Flow coil configuration.

ATWB Model Number†	Weights (lbs)			Fans		Spray Pump		Coil Volume (Gallons)	Remote Sump <sup>△</sup>			Dimensions <sup>■</sup>			
	Shipping	Heaviest Section††	Operating	HP	CFM	HP	GPM		Gallons* <sup>*</sup> Required	Conn. Size	Operating Weight (lbs)	Coil A	Upper U	Lower E	Height H
ATWB 12-3L40	44,720	17,850	73,660	[2] 25	249,720	[2] 10	2,800	1,021	1,600	[2] 14"	60,260	22-1/4"	8' 3-5/8"	7' 2-1/4"	15' 5-7/8"
ATWB 12-3M40	44,820	17,900	73,760	[2] 30	265,370	[2] 10	2,800	1,021	1,600	[2] 14"	60,360	22-1/4"	8' 3-5/8"	7' 2-1/4"	15' 5-7/8"
ATWB 12-3N40	45,140	18,060	74,080	[2] 40	289,620	[2] 10	2,800	1,021	1,600	[2] 14"	60,680	22-1/4"	8' 3-5/8"	7' 2-1/4"	15' 5-7/8"
ATWB 12-3O40	45,160	18,070	74,100	[2] 50	308,300	[2] 10	2,800	1,021	1,600	[2] 14"	60,700	22-1/4"	8' 3-5/8"	7' 2-1/4"	15' 5-7/8"
ATWB 12-4L40	52,280	21,630	83,960	[2] 25	242,450	[2] 10	2,800	1,349	1,600	[2] 14"	70,560	30-3/4"	9' 1/8"	7' 2-1/4"	16' 2-3/8"
ATWB 12-4M40	52,380	21,680	84,060	[2] 30	257,640	[2] 10	2,800	1,349	1,600	[2] 14"	70,660	30-3/4"	9' 1/8"	7' 2-1/4"	16' 2-3/8"
ATWB 12-4N40	52,700	21,840	84,380	[2] 40	281,190	[2] 10	2,800	1,349	1,600	[2] 14"	70,980	30-3/4"	9' 1/8"	7' 2-1/4"	16' 2-3/8"
ATWB 12-4O40	52,720	21,850	84,400	[2] 50	299,320	[2] 10	2,800	1,349	1,600	[2] 14"	71,000	30-3/4"	9' 1/8"	7' 2-1/4"	16' 2-3/8"
ATWB 12-5M40	59,740	25,360	94,160	[2] 30	249,910	[2] 10	2,800	1,676	1,600	[2] 14"	80,760	39-1/4"	9' 8-5/8"	7' 2-1/4"	16' 10-7/8"
ATWB 12-5N40	60,060	25,520	94,480	[2] 40	272,750	[2] 10	2,800	1,676	1,600	[2] 14"	81,080	39-1/4"	9' 8-5/8"	7' 2-1/4"	16' 10-7/8"
ATWB 12-5O40	60,080	25,530	94,500	[2] 50	290,340	[2] 10	2,800	1,676	1,600	[2] 14"	81,100	39-1/4"	9' 8-5/8"	7' 2-1/4"	16' 10-7/8"
ATWB 12-5P40	60,480	25,730	94,900	[2] 60	305,540	[2] 10	2,800	1,676	1,600	[2] 14"	81,500	39-1/4"	9' 8-5/8"	7' 2-1/4"	16' 10-7/8"
ATWB 12-6N40	68,360	29,670	105,500	[2] 40	264,320	[2] 10	2,800	2,004	1,600	[2] 14"	92,100	47-3/4"	10' 5-1/8"	7' 2-1/4"	17' 7-3/8"
ATWB 12-6O40	68,380	29,680	105,520	[2] 50	281,360	[2] 10	2,800	2,004	1,600	[2] 14"	92,120	47-3/4"	10' 5-1/8"	7' 2-1/4"	17' 7-3/8"
ATWB 12-6P40	68,780	29,880	105,920	[2] 60	296,090	[2] 10	2,800	2,004	1,600	[2] 14"	92,520	47-3/4"	10' 5-1/8"	7' 2-1/4"	17' 7-3/8"
ATWB 12-7N40	77,220	34,100	117,100	[2] 40	255,880	[2] 10	2,800	2,331	1,600	[2] 14"	103,700	47-3/4"	10' 5-1/8"	7' 2-1/4"	17' 7-3/8"
ATWB 12-7O40	77,240	34,110	117,120	[2] 50	272,380	[2] 10	2,800	2,331	1,600	[2] 14"	103,720	47-3/4"	10' 5-1/8"	7' 2-1/4"	17' 7-3/8"
ATWB 12-7P40	77,640	34,310	117,520	[2] 60	286,650	[2] 10	2,800	2,331	1,600	[2] 14"	104,120	47-3/4"	10' 5-1/8"	7' 2-1/4"	17' 7-3/8"

† Model Numbers end in "-Z" for units with Series Flow piping configuration. Series Flow units may require additional coil connections and will require crossover piping. Model numbers will include "C" for units with Stainless Steel coil(s), "R" for units with Low Sound Fan(s) and "S" for units with an option that negates CTI certification.

†† Heaviest section is the coil/fan section.

\* Gallons shown is water in suspension in unit and piping. Allow for additional water in bottom of remote sump to cover pump suction and strainer during operation (12" would normally be sufficient).

△ When a remote sump arrangement is selected, the spray pump, suction strainer and associated piping are omitted; the unit is provided with an oversized outlet to facilitate drainage to the remote sump.

■ Unit dimensions and coil connections may vary slightly from catalog. See factory certified prints for dimensions, quantity of coil connections, and piping configuration. Coil connections are 4" bevel for weld (BFW). Other connection types such as grooved for mechanical coupling or flanged are also available as options.

# ATWB 24-3J12 to 24-7N12

Selections for ATWB Closed Circuit Coolers are available from EVAPCO's **SPECTRUM™** Program. Please contact your local sales representative for more information on the **SPECTRUM™** program.

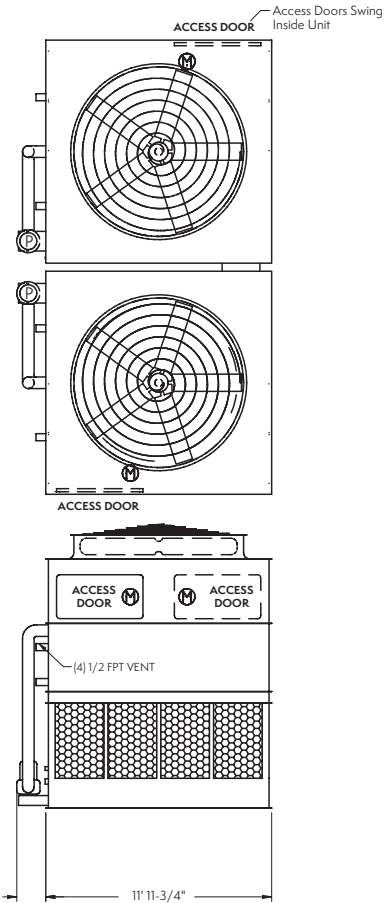
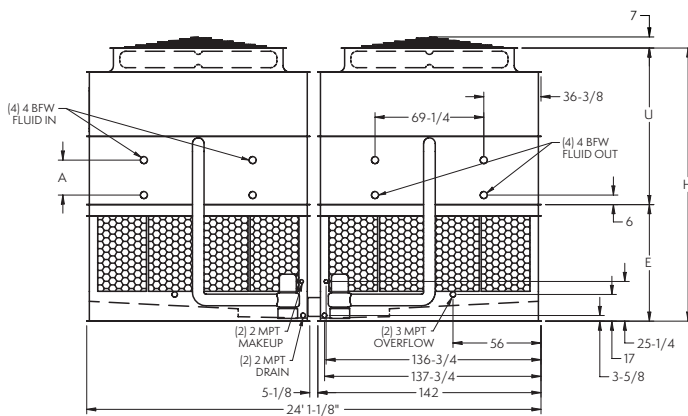

NOTE: The number of coil connections doubles when the flow rate exceeds 1,800 GPM on ATWB 24x12 models. This required option is referred to as the High Flow coil configuration.

ATWB Model Number†	Weights (lbs)			Fans		Spray Pump		Coil Volume (Gallons)	Remote Sump <sup>Δ</sup>			Dimensions <sup>■</sup>			
	Shipping	Heaviest Section††	Operating	HP	CFM	HP	GPM		Gallons* Required	Conn. Size	Operating Weight (lbs)	Coil A	Upper U	Lower E	Height H
ATWB 24-3J12	28,500	11,540	45,740	(2) 15	145,000	(2) 5	1,600	623	980	(2) 12"	37,840	22-1/4"	8' 3-5/8"	6' 2-1/4"	14' 5-7/8"
ATWB 24-3K12	28,620	11,600	45,860	(2) 20	159,590	(2) 5	1,600	623	980	(2) 12"	37,960	22-1/4"	8' 3-5/8"	6' 2-1/4"	14' 5-7/8"
ATWB 24-3L12	28,680	11,630	45,920	(2) 25	170,080	(2) 5	1,600	623	980	(2) 12"	38,020	22-1/4"	8' 3-5/8"	6' 2-1/4"	14' 5-7/8"
ATWB 24-3M12	28,780	11,680	46,020	(2) 30	178,990	(2) 5	1,600	623	980	(2) 12"	38,120	22-1/4"	8' 3-5/8"	6' 2-1/4"	14' 5-7/8"
ATWB 24-4K12	33,240	13,910	52,120	(2) 20	154,940	(2) 5	1,600	818	980	(2) 12"	44,220	30-3/4"	9' 1/8"	6' 2-1/4"	15' 2-3/8"
ATWB 24-4L12	33,300	13,940	52,180	(2) 25	165,130	(2) 5	1,600	818	980	(2) 12"	44,280	30-3/4"	9' 1/8"	6' 2-1/4"	15' 2-3/8"
ATWB 24-4M12	33,400	13,990	52,280	(2) 30	173,780	(2) 5	1,600	818	980	(2) 12"	44,380	30-3/4"	9' 1/8"	6' 2-1/4"	15' 2-3/8"
ATWB 24-4N12	33,720	14,150	52,600	(2) 40	188,350	(2) 5	1,600	818	980	(2) 12"	44,700	30-3/4"	9' 1/8"	6' 2-1/4"	15' 2-3/8"
ATWB 24-5K12	37,600	16,090	58,100	(2) 20	150,290	(2) 5	1,600	1,013	980	(2) 12"	50,200	39-1/4"	9' 8-5/8"	6' 2-1/4"	15' 10-7/8"
ATWB 24-5L12	37,660	16,120	58,160	(2) 25	160,170	(2) 5	1,600	1,013	980	(2) 12"	50,260	39-1/4"	9' 8-5/8"	6' 2-1/4"	15' 10-7/8"
ATWB 24-5M12	37,760	16,170	58,260	(2) 30	168,560	(2) 5	1,600	1,013	980	(2) 12"	50,360	39-1/4"	9' 8-5/8"	6' 2-1/4"	15' 10-7/8"
ATWB 24-5N12	38,080	16,330	58,580	(2) 40	182,700	(2) 5	1,600	1,013	980	(2) 12"	50,680	39-1/4"	9' 8-5/8"	6' 2-1/4"	15' 10-7/8"
ATWB 24-6L12	42,380	18,480	64,500	(2) 25	155,220	(2) 5	1,600	1,208	980	(2) 12"	56,600	47-3/4"	10' 5-1/8"	6' 2-1/4"	16' 7-3/8"
ATWB 24-6M12	42,480	18,530	64,600	(2) 30	163,350	(2) 5	1,600	1,208	980	(2) 12"	56,700	47-3/4"	10' 5-1/8"	6' 2-1/4"	16' 7-3/8"
ATWB 24-6N12	42,800	18,690	64,920	(2) 40	177,050	(2) 5	1,600	1,208	980	(2) 12"	57,020	47-3/4"	10' 5-1/8"	6' 2-1/4"	16' 7-3/8"
ATWB 24-7L12	47,620	21,100	71,380	(2) 25	150,270	(2) 5	1,600	1,403	980	(2) 12"	63,480	47-3/4"	10' 5-1/8"	6' 2-1/4"	16' 7-3/8"
ATWB 24-7M12	47,720	21,150	71,480	(2) 30	158,140	(2) 5	1,600	1,403	980	(2) 12"	63,580	47-3/4"	10' 5-1/8"	6' 2-1/4"	16' 7-3/8"
ATWB 24-7N12	48,040	21,310	71,800	(2) 40	171,400	(2) 5	1,600	1,403	980	(2) 12"	63,900	47-3/4"	10' 5-1/8"	6' 2-1/4"	16' 7-3/8"

† Model Numbers end in "-Z" for units with Series Flow piping configuration. Series Flow units may require additional coil connections and will require crossover piping. Model numbers will include "C" for units with Stainless Steel coil(s), "R" for units with Low Sound Fan(s) and "S" for units with an option that negates CTI certification.

†† Heaviest section is the coil/fan section.

\* Gallons shown is water in suspension in unit and piping. Allow for additional water in bottom of remote sump to cover pump suction and strainer during operation (12" would normally be sufficient).

Δ When a remote sump arrangement is selected, the spray pump, suction strainer and associated piping are omitted; the unit is provided with an oversized outlet to facilitate drainage to the remote sump.

■ Unit dimensions and coil connections may vary slightly from catalog. See factory certified prints for dimensions, quantity of coil connections, and piping configuration. Coil connections are 4" bevel for weld (BFW). Other connection types such as grooved for mechanical coupling or flanged are also available as options.



# ATWB 24-3K14 to 24-7N14

Selections for ATWB Closed Circuit Coolers are available from EVAPCO's **SPECTRUM™** Program. Please contact your local sales representative for more information on the **SPECTRUM™** program.

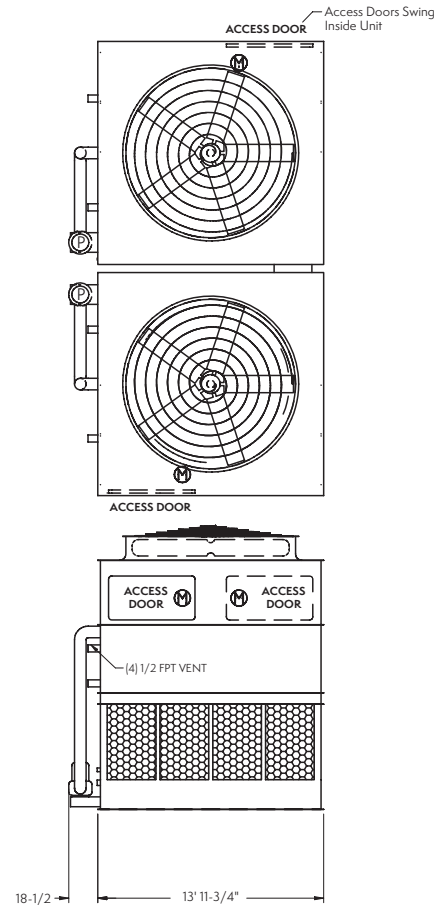
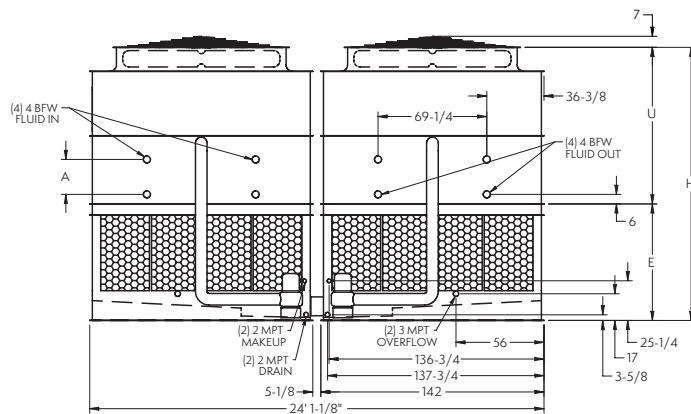

NOTE: The number of coil connections doubles when the flow rate exceeds 1,800 GPM on ATWB 24x14 models. This required option is referred to as the High Flow coil configuration.

ATWB Model Number†	Weights (lbs)			Fans		Spray Pump		Coil Volume (Gallons)	Remote Sump Δ			Dimensions ■			
	Shipping	Heaviest Section††	Operating	HP	CFM	HP	GPM		Gallons* Required	Conn. Size	Operating Weight (lbs)	Coil A	Upper U	Lower E	Height H
ATWB 24-3K14	32,340	13,110	52,580	(2) 20	176,900	(2) 5	1,800	723	1,140	(2) 12"	43,440	22-1/4"	8' 3-5/8"	7' 2-1/4"	15' 5-7/8"
ATWB 24-3L14	32,400	13,140	52,640	(2) 25	190,090	(2) 5	1,800	723	1,140	(2) 12"	43,500	22-1/4"	8' 3-5/8"	7' 2-1/4"	15' 5-7/8"
ATWB 24-3M14	32,500	13,190	52,740	(2) 30	200,050	(2) 5	1,800	723	1,140	(2) 12"	43,600	22-1/4"	8' 3-5/8"	7' 2-1/4"	15' 5-7/8"
ATWB 24-3N14	32,820	13,350	53,060	(2) 40	216,830	(2) 5	1,800	723	1,140	(2) 12"	43,920	22-1/4"	8' 3-5/8"	7' 2-1/4"	15' 5-7/8"
ATWB 24-4K14	37,720	15,800	59,860	(2) 20	171,750	(2) 5	1,800	951	1,140	(2) 12"	50,720	30-3/4"	9' 1/8"	7' 2-1/4"	16' 2-3/8"
ATWB 24-4L14	37,780	15,830	59,920	(2) 25	184,560	(2) 5	1,800	951	1,140	(2) 12"	50,780	30-3/4"	9' 1/8"	7' 2-1/4"	16' 2-3/8"
ATWB 24-4M14	37,880	15,880	60,020	(2) 30	194,220	(2) 5	1,800	951	1,140	(2) 12"	50,880	30-3/4"	9' 1/8"	7' 2-1/4"	16' 2-3/8"
ATWB 24-4N14	38,200	16,040	60,340	(2) 40	210,510	(2) 5	1,800	951	1,140	(2) 12"	51,200	30-3/4"	9' 1/8"	7' 2-1/4"	16' 2-3/8"
ATWB 24-5L14	42,780	18,330	66,820	(2) 25	179,020	(2) 5	1,800	1,179	1,140	(2) 12"	57,680	39-1/4"	9' 8-5/8"	7' 2-1/4"	16' 10-7/8"
ATWB 24-5M14	42,880	18,380	66,920	(2) 30	188,400	(2) 5	1,800	1,179	1,140	(2) 12"	57,780	39-1/4"	9' 8-5/8"	7' 2-1/4"	16' 10-7/8"
ATWB 24-5N14	43,200	18,540	67,240	(2) 40	204,200	(2) 5	1,800	1,179	1,140	(2) 12"	58,100	39-1/4"	9' 8-5/8"	7' 2-1/4"	16' 10-7/8"
ATWB 24-6L14	48,780	21,330	74,720	(2) 25	173,480	(2) 5	1,800	1,407	1,140	(2) 12"	65,580	47-3/4"	10' 5-1/8"	7' 2-1/4"	17' 7-3/8"
ATWB 24-6M14	48,880	21,380	74,820	(2) 30	182,570	(2) 5	1,800	1,407	1,140	(2) 12"	65,680	47-3/4"	10' 5-1/8"	7' 2-1/4"	17' 7-3/8"
ATWB 24-6N14	49,200	21,540	75,140	(2) 40	197,880	(2) 5	1,800	1,407	1,140	(2) 12"	66,000	47-3/4"	10' 5-1/8"	7' 2-1/4"	17' 7-3/8"
ATWB 24-7L14	54,980	24,430	82,820	(2) 25	167,950	(2) 5	1,800	1,635	1,140	(2) 12"	73,680	47-3/4"	10' 5-1/8"	7' 2-1/4"	17' 7-3/8"
ATWB 24-7M14	55,080	24,480	82,920	(2) 30	176,740	(2) 5	1,800	1,635	1,140	(2) 12"	73,780	47-3/4"	10' 5-1/8"	7' 2-1/4"	17' 7-3/8"
ATWB 24-7N14	55,400	24,640	83,240	(2) 40	191,570	(2) 5	1,800	1,635	1,140	(2) 12"	74,100	47-3/4"	10' 5-1/8"	7' 2-1/4"	17' 7-3/8"

† Model Numbers end in "-Z" for units with Series Flow piping configuration. Series Flow units may require additional coil connections and will require crossover piping. Model numbers will include "C" for units with Stainless Steel coil(s), "R" for units with Low Sound Fan(s) and "S" for units with an option that negates CTI certification.

†† Heaviest section is the coil/fan section.

\* Gallons shown is water in suspension in unit and piping. Allow for additional water in bottom of remote sump to cover pump suction and strainer during operation (12" would normally be sufficient).

Δ When a remote sump arrangement is selected, the spray pump, suction strainer and associated piping are omitted; the unit is provided with an oversized outlet to facilitate drainage to the remote sump.

■ Unit dimensions and coil connections may vary slightly from catalog. See factory certified prints for dimensions, quantity of coil connections, and piping configuration. Coil connections are 4" bevel for weld (BFW). Other connection types such as grooved for mechanical coupling or flanged are also available as options.

# ATWB 24-3K18 to 24-7P18

Selections for ATWB Closed Circuit Coolers are available from EVAPCO's **SPECTRUM™** Program. Please contact your local sales representative for more information on the **SPECTRUM™** program.

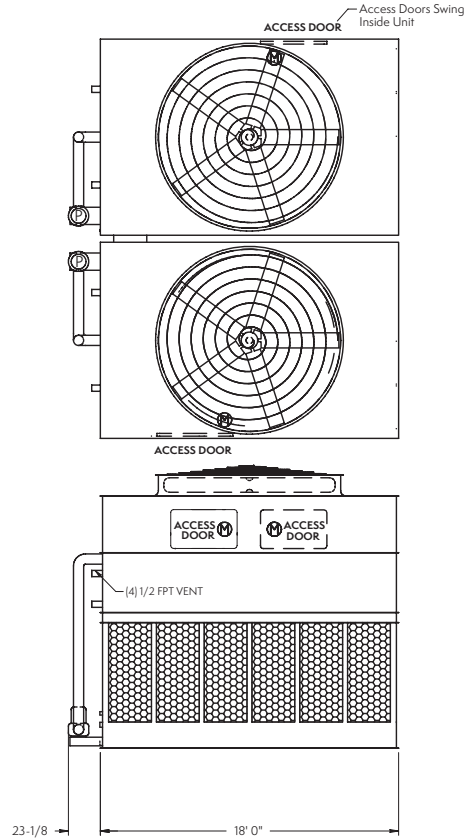
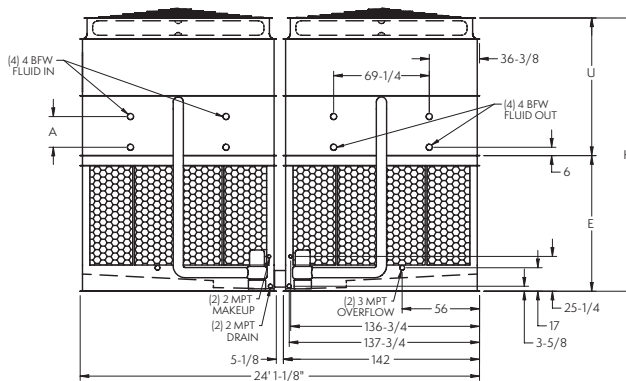

NOTE: The number of coil connections doubles when the flow rate exceeds 1,800 GPM on ATWB 24x18 models. This required option is referred to as the High Flow coil configuration.

ATWB Model Number†	Weights (lbs)			Fans		Spray Pump		Coil Volume (Gallons)	Remote Sump △			Dimensions ■			
	Shipping	Heaviest Section††	Operating	HP	CFM	HP	GPM		Gallons* Required	Conn. Size	Operating Weight (lbs)	Coil A	Upper U	Lower E	Height H
ATWB 24-3K18	40,520	16,340	66,400	(2) 20	216,080	(2) 7.5	2,400	922	1,440	(2) 12"	54,660	22-1/4"	8' 3-5/8"	8' 2-1/4"	16' 5-7/8"
ATWB 24-3L18	40,580	16,370	66,460	(2) 25	232,770	(2) 7.5	2,400	922	1,440	(2) 12"	54,720	22-1/4"	8' 3-5/8"	8' 2-1/4"	16' 5-7/8"
ATWB 24-3M18	40,680	16,420	66,560	(2) 30	247,350	(2) 7.5	2,400	922	1,440	(2) 12"	54,820	22-1/4"	8' 3-5/8"	8' 2-1/4"	16' 5-7/8"
ATWB 24-3N18	41,000	16,580	66,880	(2) 40	268,450	(2) 7.5	2,400	922	1,440	(2) 12"	55,140	22-1/4"	8' 3-5/8"	8' 2-1/4"	16' 5-7/8"
ATWB 24-4K18	47,380	19,770	75,720	(2) 20	209,790	(2) 7.5	2,400	1,216	1,440	(2) 12"	63,980	30-3/4"	9' 1/8"	8' 2-1/4"	17' 2-3/8"
ATWB 24-4L18	47,440	19,800	75,780	(2) 25	225,990	(2) 7.5	2,400	1,216	1,440	(2) 12"	64,040	30-3/4"	9' 1/8"	8' 2-1/4"	17' 2-3/8"
ATWB 24-4M18	47,540	19,850	75,880	(2) 30	240,150	(2) 7.5	2,400	1,216	1,440	(2) 12"	64,140	30-3/4"	9' 1/8"	8' 2-1/4"	17' 2-3/8"
ATWB 24-4N18	47,860	20,010	76,200	(2) 40	260,630	(2) 7.5	2,400	1,216	1,440	(2) 12"	64,460	30-3/4"	9' 1/8"	8' 2-1/4"	17' 2-3/8"
ATWB 24-4O18	47,880	20,020	76,220	(2) 50	277,440	(2) 7.5	2,400	1,216	1,440	(2) 12"	64,480	30-3/4"	9' 1/8"	8' 2-1/4"	17' 2-3/8"
ATWB 24-5L18	54,040	23,100	84,820	(2) 25	219,210	(2) 7.5	2,400	1,510	1,440	(2) 12"	73,080	39-1/4"	9' 8-5/8"	8' 2-1/4"	17' 10-7/8"
ATWB 24-5M18	54,140	23,150	84,920	(2) 30	232,940	(2) 7.5	2,400	1,510	1,440	(2) 12"	73,180	39-1/4"	9' 8-5/8"	8' 2-1/4"	17' 10-7/8"
ATWB 24-5N18	54,460	23,310	85,240	(2) 40	252,810	(2) 7.5	2,400	1,510	1,440	(2) 12"	73,500	39-1/4"	9' 8-5/8"	8' 2-1/4"	17' 10-7/8"
ATWB 24-5O18	54,480	23,320	85,260	(2) 50	269,110	(2) 7.5	2,400	1,510	1,440	(2) 12"	73,520	39-1/4"	9' 8-5/8"	8' 2-1/4"	17' 10-7/8"
ATWB 24-6M18	60,920	26,540	94,160	(2) 30	225,740	(2) 7.5	2,400	1,805	1,440	(2) 12"	82,420	47-3/4"	10' 5-1/8"	8' 2-1/4"	18' 7-3/8"
ATWB 24-6N18	61,240	26,700	94,480	(2) 40	244,990	(2) 7.5	2,400	1,805	1,440	(2) 12"	82,740	47-3/4"	10' 5-1/8"	8' 2-1/4"	18' 7-3/8"
ATWB 24-6O18	61,260	26,710	94,500	(2) 50	260,790	(2) 7.5	2,400	1,805	1,440	(2) 12"	82,760	47-3/4"	10' 5-1/8"	8' 2-1/4"	18' 7-3/8"
ATWB 24-6P18	61,660	26,910	94,900	(2) 60	274,450	(2) 7.5	2,400	1,805	1,440	(2) 12"	83,160	47-3/4"	10' 5-1/8"	8' 2-1/4"	18' 7-3/8"
ATWB 24-7M18	68,760	30,460	104,460	(2) 30	218,530	(2) 7.5	2,400	2,099	1,440	(2) 12"	92,720	47-3/4"	10' 5-1/8"	8' 2-1/4"	18' 7-3/8"
ATWB 24-7N18	69,080	30,620	104,780	(2) 40	237,170	(2) 7.5	2,400	2,099	1,440	(2) 12"	93,040	47-3/4"	10' 5-1/8"	8' 2-1/4"	18' 7-3/8"
ATWB 24-7O18	69,100	30,630	104,800	(2) 50	252,470	(2) 7.5	2,400	2,099	1,440	(2) 12"	93,060	47-3/4"	10' 5-1/8"	8' 2-1/4"	18' 7-3/8"
ATWB 24-7P18	69,500	30,830	105,200	(2) 60	265,690	(2) 7.5	2,400	2,099	1,440	(2) 12"	93,460	47-3/4"	10' 5-1/8"	8' 2-1/4"	18' 7-3/8"

† Model Numbers end in "-Z" for units with Series Flow piping configuration. Series Flow units may require additional coil connections and will require crossover piping. Model numbers will include "C" for units with Stainless Steel coil(s), "R" for units with Low Sound Fan(s) and "S" for units with an option that negates CTI certification.

†† Heaviest section is the coil/fan section.

\* Gallons shown is water in suspension in unit and piping. Allow for additional water in bottom of remote sump to cover pump suction and strainer during operation (12" would normally be sufficient).

△ When a remote sump arrangement is selected, the spray pump, suction strainer and associated piping are omitted; the unit is provided with an oversized outlet to facilitate drainage to the remote sump.

■ Unit dimensions and coil connections may vary slightly from catalog. See factory certified prints for dimensions, quantity of coil connections, and piping configuration. Coil connections are 4" bevel for weld (BFW). Other connection types such as grooved for mechanical coupling or flanged are also available as options.

# ATWB 24-3L20 to 24-7P20

Selections for ATWB Closed Circuit Coolers are available from EVAPCO's **SPECTRUM™** Program. Please contact your local sales representative for more information on the **SPECTRUM™** program.

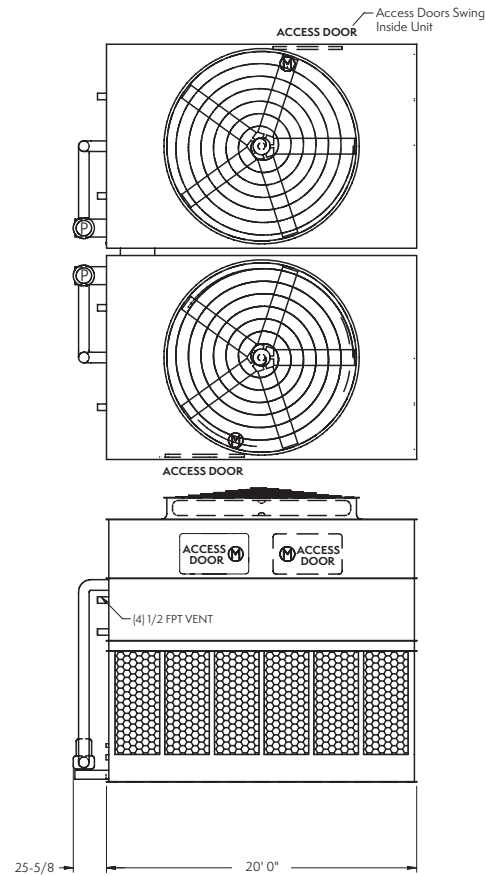
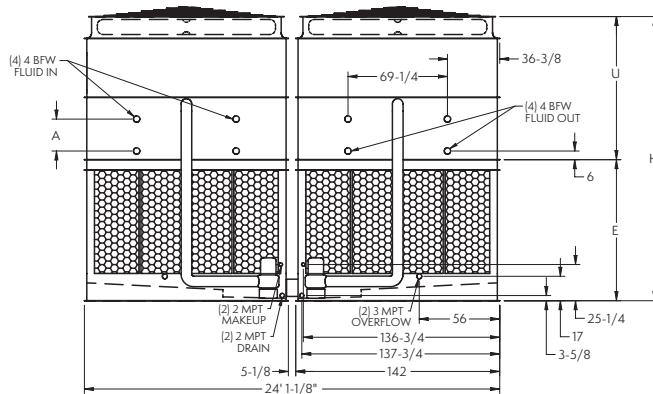

NOTE: The number of coil connections doubles when the flow rate exceeds 1,800 GPM on ATWB 24x20 models. This required option is referred to as the High Flow coil configuration.

ATWB Model Number†	Weights (lbs)			Fans		Spray Pump		Coil Volume (Gallons)	Remote Sump ▲			Dimensions ■			
	Shipping	Heaviest Section††	Operating	HP	CFM	HP	GPM		Gallons* Required	Conn. Size	Operating Weight (lbs)	Coil A	Upper U	Lower E	Height H
ATWB 24-3L20	44,720	17,850	73,660	[2] 25	249,720	[2] 10	2,800	1,021	1,600	[2] 14"	60,260	22-1/4"	8' 3-5/8"	8' 2-1/4"	16' 5-7/8"
ATWB 24-3M20	44,820	17,900	73,760	[2] 30	265,370	[2] 10	2,800	1,021	1,600	[2] 14"	60,360	22-1/4"	8' 3-5/8"	8' 2-1/4"	16' 5-7/8"
ATWB 24-3N20	45,140	18,060	74,080	[2] 40	289,620	[2] 10	2,800	1,021	1,600	[2] 14"	60,680	22-1/4"	8' 3-5/8"	8' 2-1/4"	16' 5-7/8"
ATWB 24-3O20	45,160	18,070	74,100	[2] 50	308,300	[2] 10	2,800	1,021	1,600	[2] 14"	60,700	22-1/4"	8' 3-5/8"	8' 2-1/4"	16' 5-7/8"
ATWB 24-4L20	52,280	21,630	83,960	[2] 25	242,450	[2] 10	2,800	1,349	1,600	[2] 14"	70,560	30-3/4"	9' 1/8"	8' 2-1/4"	17' 2-3/8"
ATWB 24-4M20	52,380	21,680	84,060	[2] 30	257,640	[2] 10	2,800	1,349	1,600	[2] 14"	70,660	30-3/4"	9' 1/8"	8' 2-1/4"	17' 2-3/8"
ATWB 24-4N20	52,700	21,840	84,380	[2] 40	281,190	[2] 10	2,800	1,349	1,600	[2] 14"	70,980	30-3/4"	9' 1/8"	8' 2-1/4"	17' 2-3/8"
ATWB 24-4O20	52,720	21,850	84,400	[2] 50	299,320	[2] 10	2,800	1,349	1,600	[2] 14"	71,000	30-3/4"	9' 1/8"	8' 2-1/4"	17' 2-3/8"
ATWB 24-5M20	59,740	25,360	94,160	[2] 30	249,910	[2] 10	2,800	1,676	1,600	[2] 14"	80,760	39-1/4"	9' 8-5/8"	8' 2-1/4"	17' 10-7/8"
ATWB 24-5N20	60,060	25,520	94,480	[2] 40	272,750	[2] 10	2,800	1,676	1,600	[2] 14"	81,080	39-1/4"	9' 8-5/8"	8' 2-1/4"	17' 10-7/8"
ATWB 24-5O20	60,080	25,530	94,500	[2] 50	290,340	[2] 10	2,800	1,676	1,600	[2] 14"	81,100	39-1/4"	9' 8-5/8"	8' 2-1/4"	17' 10-7/8"
ATWB 24-5P20	60,480	25,730	94,900	[2] 60	305,540	[2] 10	2,800	1,676	1,600	[2] 14"	81,500	39-1/4"	9' 8-5/8"	8' 2-1/4"	17' 10-7/8"
ATWB 24-6N20	68,360	29,670	105,500	[2] 40	264,320	[2] 10	2,800	2,004	1,600	[2] 14"	92,100	47-3/4"	10' 5-1/8"	8' 2-1/4"	18' 7-3/8"
ATWB 24-6O20	68,380	29,680	105,520	[2] 50	281,360	[2] 10	2,800	2,004	1,600	[2] 14"	92,120	47-3/4"	10' 5-1/8"	8' 2-1/4"	18' 7-3/8"
ATWB 24-6P20	68,780	29,880	105,920	[2] 60	296,090	[2] 10	2,800	2,004	1,600	[2] 14"	92,520	47-3/4"	10' 5-1/8"	8' 2-1/4"	18' 7-3/8"
ATWB 24-7N20	77,220	34,100	117,100	[2] 40	255,880	[2] 10	2,800	2,331	1,600	[2] 14"	103,700	47-3/4"	10' 5-1/8"	8' 2-1/4"	18' 7-3/8"
ATWB 24-7O20	77,240	34,110	117,120	[2] 50	272,380	[2] 10	2,800	2,331	1,600	[2] 14"	103,720	47-3/4"	10' 5-1/8"	8' 2-1/4"	18' 7-3/8"
ATWB 24-7P20	77,640	34,310	117,520	[2] 60	286,650	[2] 10	2,800	2,331	1,600	[2] 14"	104,120	47-3/4"	10' 5-1/8"	8' 2-1/4"	18' 7-3/8"

† Model Numbers end in "-Z" for units with Series Flow piping configuration. Series Flow units may require additional coil connections and will require crossover piping. Model numbers will include "C" for units with Stainless Steel coil(s), "R" for units with Low Sound Fan(s) and "S" for units with an option that negates CTI certification.

†† Heaviest section is the coil/fan section.

\* Gallons shown is water in suspension in unit and piping. Allow for additional water in bottom of remote sump to cover pump suction and strainer during operation (12" would normally be sufficient).

▲ When a remote sump arrangement is selected, the spray pump, suction strainer and associated piping are omitted; the unit is provided with an oversized outlet to facilitate drainage to the remote sump.

■ Unit dimensions and coil connections may vary slightly from catalog. See factory certified prints for dimensions, quantity of coil connections, and piping configuration. Coil connections are 4" bevel for weld (BFW). Other connection types such as grooved for mechanical coupling or flanged are also available as options.

# ATWB 24-3J24 to 24-7N24

Selections for ATWB Closed Circuit Coolers are available from EVAPCO's **SPECTRUM™** Program. Please contact your local sales representative for more information on the **SPECTRUM™** program.

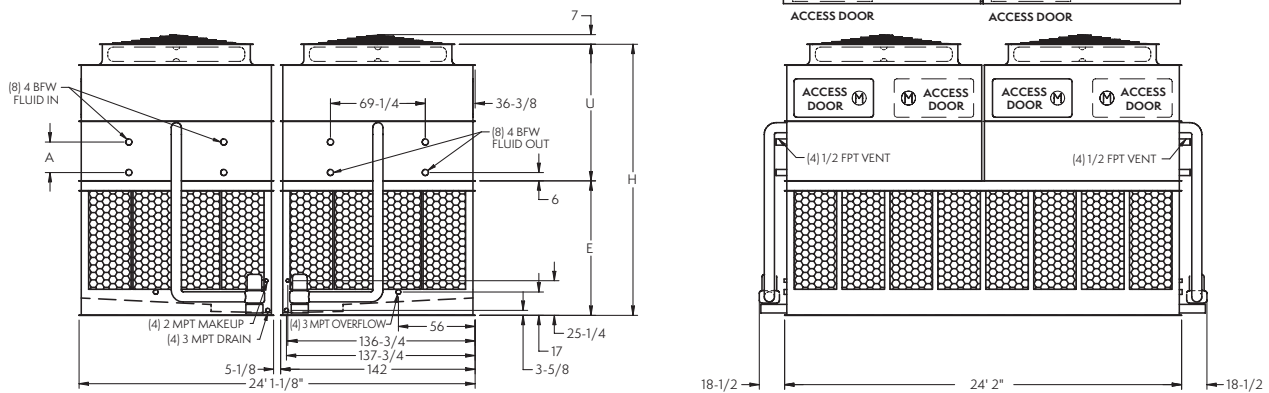

NOTE: The number of coil connections doubles when the flow rate exceeds 3,600 GPM on ATWB 24x24 models. This required option is referred to as the High Flow coil configuration.

ATWB Model Number†	Weights (lbs)			Fans		Spray Pump		Coil Volume (Gallons)	Remote Sump ▲			Dimensions ■			
	Shipping	Heaviest Section††	Operating	HP	CFM	HP	GPM		Gallons* Required	Conn. Size	Operating Weight (lbs)	Coil A	Upper U	Lower E	Height H
ATWB 24-3J24	57,340	11,540	91,840	(4) 15	289,990	(4) 5	3,200	1,246	1,960	(4) 12"	75,780	22-1/4"	8' 3-5/8"	8' 2-1/4"	16' 5-7/8"
ATWB 24-3K24	57,580	11,600	92,080	(4) 20	319,180	(4) 5	3,200	1,246	1,960	(4) 12"	76,020	22-1/4"	8' 3-5/8"	8' 2-1/4"	16' 5-7/8"
ATWB 24-3L24	57,700	11,630	92,200	(4) 25	340,160	(4) 5	3,200	1,246	1,960	(4) 12"	76,140	22-1/4"	8' 3-5/8"	8' 2-1/4"	16' 5-7/8"
ATWB 24-3M24	57,900	11,680	92,400	(4) 30	357,980	(4) 5	3,200	1,246	1,960	(4) 12"	76,340	22-1/4"	8' 3-5/8"	8' 2-1/4"	16' 5-7/8"
ATWB 24-4J24	66,580	13,850	104,360	(4) 15	281,550	(4) 5	3,200	1,636	1,960	(4) 12"	88,300	30-3/4"	9' 1/8"	8' 2-1/4"	17' 2-3/8"
ATWB 24-4K24	66,820	13,910	104,600	(4) 20	309,880	(4) 5	3,200	1,636	1,960	(4) 12"	88,540	30-3/4"	9' 1/8"	8' 2-1/4"	17' 2-3/8"
ATWB 24-4L24	66,940	13,940	104,720	(4) 25	330,250	(4) 5	3,200	1,636	1,960	(4) 12"	88,660	30-3/4"	9' 1/8"	8' 2-1/4"	17' 2-3/8"
ATWB 24-4M24	67,140	13,990	104,920	(4) 30	347,550	(4) 5	3,200	1,636	1,960	(4) 12"	88,860	30-3/4"	9' 1/8"	8' 2-1/4"	17' 2-3/8"
ATWB 24-4N24	67,780	14,150	105,560	(4) 40	376,710	(4) 5	3,200	1,636	1,960	(4) 12"	89,500	30-3/4"	9' 1/8"	8' 2-1/4"	17' 2-3/8"
ATWB 24-5K24	75,540	16,090	116,560	(4) 20	300,580	(4) 5	3,200	2,026	1,960	(4) 12"	100,500	39-1/4"	9' 8-5/8"	8' 2-1/4"	17' 10-7/8"
ATWB 24-5L24	75,660	16,120	116,680	(4) 25	320,350	(4) 5	3,200	2,026	1,960	(4) 12"	100,620	39-1/4"	9' 8-5/8"	8' 2-1/4"	17' 10-7/8"
ATWB 24-5M24	75,860	16,170	116,880	(4) 30	337,130	(4) 5	3,200	2,026	1,960	(4) 12"	100,820	39-1/4"	9' 8-5/8"	8' 2-1/4"	17' 10-7/8"
ATWB 24-5N24	76,500	16,330	117,520	(4) 40	365,400	(4) 5	3,200	2,026	1,960	(4) 12"	101,460	39-1/4"	9' 8-5/8"	8' 2-1/4"	17' 10-7/8"
ATWB 24-6L24	85,100	18,480	129,360	(4) 25	310,440	(4) 5	3,200	2,415	1,960	(4) 12"	113,300	47-3/4"	10' 5-1/8"	8' 2-1/4"	18' 7-3/8"
ATWB 24-6M24	85,300	18,530	129,560	(4) 30	326,700	(4) 5	3,200	2,415	1,960	(4) 12"	113,500	47-3/4"	10' 5-1/8"	8' 2-1/4"	18' 7-3/8"
ATWB 24-6N24	85,940	18,690	130,200	(4) 40	354,100	(4) 5	3,200	2,415	1,960	(4) 12"	114,140	47-3/4"	10' 5-1/8"	8' 2-1/4"	18' 7-3/8"
ATWB 24-7L24	95,580	21,100	143,120	(4) 25	300,530	(4) 5	3,200	2,805	1,960	(4) 12"	127,060	47-3/4"	10' 5-1/8"	8' 2-1/4"	18' 7-3/8"
ATWB 24-7M24	95,780	21,150	143,320	(4) 30	316,270	(4) 5	3,200	2,805	1,960	(4) 12"	127,260	47-3/4"	10' 5-1/8"	8' 2-1/4"	18' 7-3/8"
ATWB 24-7N24	96,420	21,310	143,960	(4) 40	342,800	(4) 5	3,200	2,805	1,960	(4) 12"	127,900	47-3/4"	10' 5-1/8"	8' 2-1/4"	18' 7-3/8"

† Model Numbers end in "-Z" for units with Series Flow piping configuration. Series Flow units may require additional coil connections and will require crossover piping. Model numbers will include "C" for units with Stainless Steel coil(s), "R" for units with Low Sound Fan(s) and "S" for units with an option that negates CTI certification.

†† Heaviest section is the coil/fan section.

\* Gallons shown is water in suspension in unit and piping. Allow for additional water in bottom of remote sump to cover pump suction and strainer during operation (12" would normally be sufficient).

▲ When a remote sump arrangement is selected, the spray pump, suction strainer and associated piping are omitted; the unit is provided with an oversized outlet to facilitate drainage to the remote sump.

■ Unit dimensions and coil connections may vary slightly from catalog. See factory certified prints for dimensions, quantity of coil connections, and piping configuration. Coil connections are 4" bevel for weld (BFW). Other connection types such as grooved for mechanical coupling or flanged are also available as options.



# ATWB 24-3K28 to 24-7N28

Selections for ATWB Closed Circuit Coolers are available from EVAPCO's **SPECTRUM™** Program. Please contact your local sales representative for more information on the **SPECTRUM™** program.

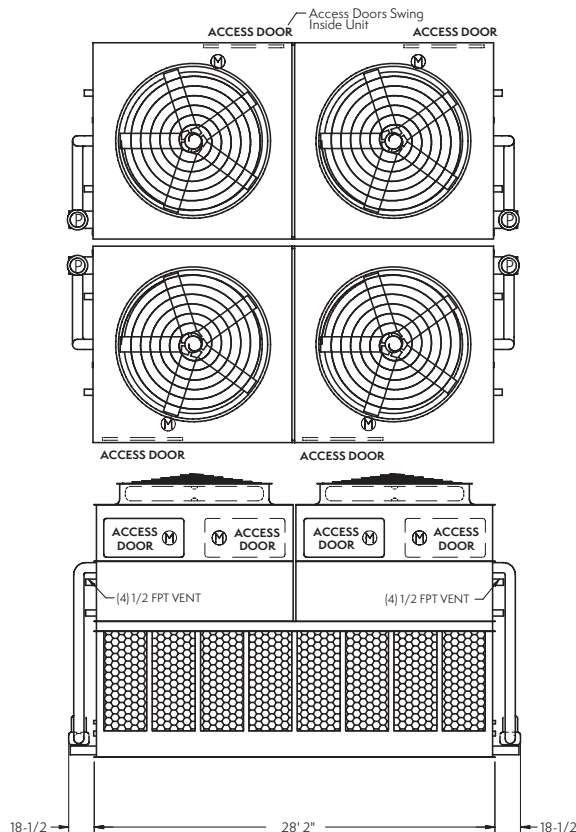
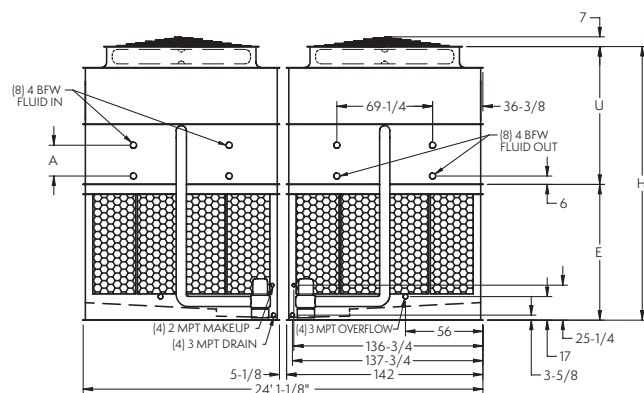

NOTE: The number of coil connections doubles when the flow rate exceeds 3,600 GPM on ATWB 24x28 models. This required option is referred to as the High Flow coil configuration.

ATWB Model Number†	Weights (lbs)			Fans		Spray Pump		Coil Volume (Gallons)	Remote Sump <sup>△</sup>		Dimensions <sup>■</sup>				
	Shipping	Heaviest Section††	Operating	HP	CFM	HP	GPM		Gallons*‡	Conn. Size	Operating Weight (lbs)	Coil A	Upper U	Lower E	Height H
ATWB 24-3K28	64,880	13,110	105,500	(4) 20	353,800	(4) 5	3,600	1,445	2,280	(4) 12"	86,940	22-1/4"	8' 3-5/8"	8' 2-1/4"	16' 5-7/8"
ATWB 24-3L28	65,000	13,140	105,620	(4) 25	380,180	(4) 5	3,600	1,445	2,280	(4) 12"	87,060	22-1/4"	8' 3-5/8"	8' 2-1/4"	16' 5-7/8"
ATWB 24-3M28	65,200	13,190	105,820	(4) 30	400,100	(4) 5	3,600	1,445	2,280	(4) 12"	87,260	22-1/4"	8' 3-5/8"	8' 2-1/4"	16' 5-7/8"
ATWB 24-3N28	65,840	13,350	106,460	(4) 40	433,660	(4) 5	3,600	1,445	2,280	(4) 12"	87,900	22-1/4"	8' 3-5/8"	8' 2-1/4"	16' 5-7/8"
ATWB 24-4K28	75,640	15,800	120,060	(4) 20	343,500	(4) 5	3,600	1,901	2,280	(4) 12"	101,500	30-3/4"	9' 1/8"	8' 2-1/4"	17' 2-3/8"
ATWB 24-4L28	75,760	15,830	120,180	(4) 25	369,110	(4) 5	3,600	1,901	2,280	(4) 12"	101,620	30-3/4"	9' 1/8"	8' 2-1/4"	17' 2-3/8"
ATWB 24-4M28	75,960	15,880	120,380	(4) 30	388,440	(4) 5	3,600	1,901	2,280	(4) 12"	101,820	30-3/4"	9' 1/8"	8' 2-1/4"	17' 2-3/8"
ATWB 24-4N28	76,600	16,040	121,020	(4) 40	421,030	(4) 5	3,600	1,901	2,280	(4) 12"	102,460	30-3/4"	9' 1/8"	8' 2-1/4"	17' 2-3/8"
ATWB 24-5L28	85,760	18,330	133,980	(4) 25	358,040	(4) 5	3,600	2,357	2,280	(4) 12"	115,420	39-1/4"	9' 8-5/8"	8' 2-1/4"	17' 10-7/8"
ATWB 24-5M28	85,960	18,380	134,180	(4) 30	376,790	(4) 5	3,600	2,357	2,280	(4) 12"	115,620	39-1/4"	9' 8-5/8"	8' 2-1/4"	17' 10-7/8"
ATWB 24-5N28	86,600	18,540	134,820	(4) 40	408,400	(4) 5	3,600	2,357	2,280	(4) 12"	116,260	39-1/4"	9' 8-5/8"	8' 2-1/4"	17' 10-7/8"
ATWB 24-6L28	97,760	21,330	149,780	(4) 25	346,960	(4) 5	3,600	2,813	2,280	(4) 12"	131,220	47-3/4"	10' 5-1/8"	8' 2-1/4"	18' 7-3/8"
ATWB 24-6M28	97,960	21,380	149,980	(4) 30	365,140	(4) 5	3,600	2,813	2,280	(4) 12"	131,420	47-3/4"	10' 5-1/8"	8' 2-1/4"	18' 7-3/8"
ATWB 24-6N28	98,600	21,540	150,620	(4) 40	395,770	(4) 5	3,600	2,813	2,280	(4) 12"	132,060	47-3/4"	10' 5-1/8"	8' 2-1/4"	18' 7-3/8"
ATWB 24-7L28	110,160	24,430	165,980	(4) 25	335,890	(4) 5	3,600	3,269	2,280	(4) 12"	147,420	47-3/4"	10' 5-1/8"	8' 2-1/4"	18' 7-3/8"
ATWB 24-7M28	110,360	24,480	166,180	(4) 30	353,480	(4) 5	3,600	3,269	2,280	(4) 12"	147,620	47-3/4"	10' 5-1/8"	8' 2-1/4"	18' 7-3/8"
ATWB 24-7N28	111,000	24,640	166,820	(4) 40	383,140	(4) 5	3,600	3,269	2,280	(4) 12"	148,260	47-3/4"	10' 5-1/8"	8' 2-1/4"	18' 7-3/8"

† Model Numbers end in "-Z" for units with Series Flow piping configuration. Series Flow units may require additional coil connections and will require crossover piping. Model numbers will include "C" for units with Stainless Steel coil(s), "R" for units with Low Sound Fan(s) and "S" for units with an option that negates CTI certification.

†† Heaviest section is the coil/fan section.

\* Gallons shown is water in suspension in unit and piping. Allow for additional water in bottom of remote sump to cover pump suction and strainer during operation (12" would normally be sufficient).

△ When a remote sump arrangement is selected, the spray pump, suction strainer and associated piping are omitted; the unit is provided with an oversized outlet to facilitate drainage to the remote sump.

■ Unit dimensions and coil connections may vary slightly from catalog. See factory certified prints for dimensions, quantity of coil connections, and piping configuration. Coil connections are 4" bevel for weld (BFW). Other connection types such as grooved for mechanical coupling or flanged are also available as options.

# ATWB 24-3K36 to 24-7P36

Selections for ATWB Closed Circuit Coolers are available from EVAPCO's **SPECTRUM™** Program. Please contact your local sales representative for more information on the **SPECTRUM™** program.

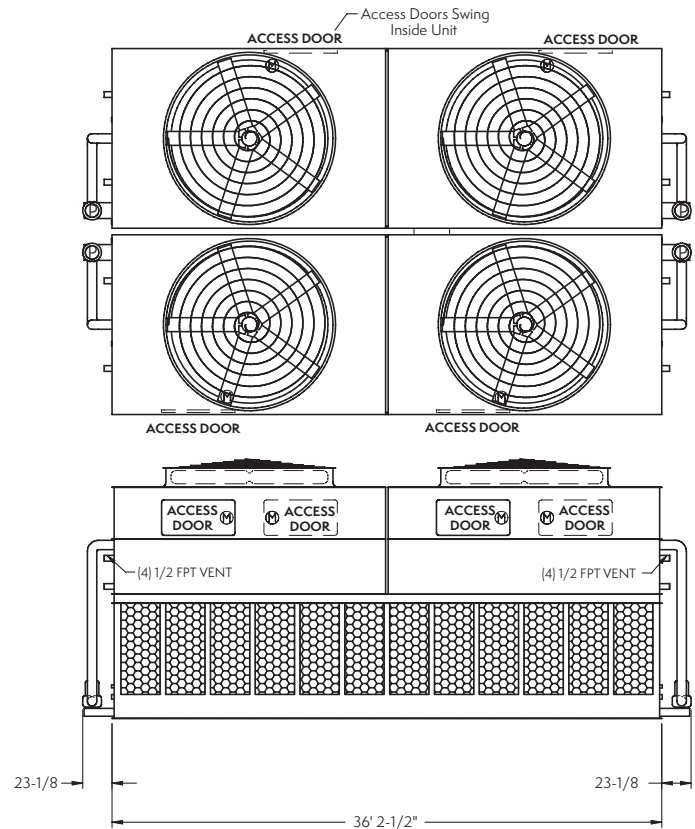
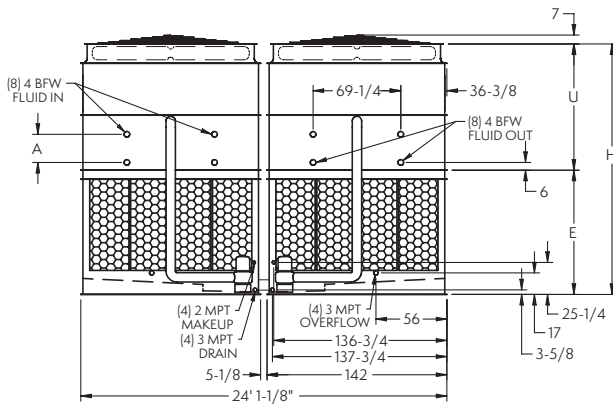

NOTE: The number of coil connections doubles when the flow rate exceeds 3,600 GPM on ATWB 24x36 models. This required option is referred to as the High Flow coil configuration.

ATWB Model Number†	Weights (lbs)			Fans		Spray Pump		Coil Volume (Gallons)	Remote Sump ▲			Dimensions ■			
	Shipping	Heaviest Section††	Operating	HP	CFM	HP	GPM		Gallons* Required	Conn. Size	Operating Weight (lbs)	Coil A	Upper U	Lower E	Height H
ATWB 24-3K36	81,640	16,340	133,600	(4) 20	418,800	(4) 7.5	4,800	1,843	2,880	(4) 12"	109,820	22-1/4"	8' 3-5/8"	8' 2-1/4"	16' 5-7/8"
ATWB 24-3L36	81,760	16,370	133,720	(4) 25	451,140	(4) 7.5	4,800	1,843	2,880	(4) 12"	109,940	22-1/4"	8' 3-5/8"	8' 2-1/4"	16' 5-7/8"
ATWB 24-3M36	81,960	16,420	133,920	(4) 30	479,400	(4) 7.5	4,800	1,843	2,880	(4) 12"	110,140	22-1/4"	8' 3-5/8"	8' 2-1/4"	16' 5-7/8"
ATWB 24-3N36	82,600	16,580	134,560	(4) 40	520,300	(4) 7.5	4,800	1,843	2,880	(4) 12"	110,780	22-1/4"	8' 3-5/8"	8' 2-1/4"	16' 5-7/8"
ATWB 24-4K36	95,360	19,770	152,240	(4) 20	406,610	(4) 7.5	4,800	2,432	2,880	(4) 12"	128,460	30-3/4"	9' 1/8"	8' 2-1/4"	17' 2-3/8"
ATWB 24-4L36	95,480	19,800	152,360	(4) 25	438,000	(4) 7.5	4,800	2,432	2,880	(4) 12"	128,580	30-3/4"	9' 1/8"	8' 2-1/4"	17' 2-3/8"
ATWB 24-4M36	95,680	19,850	152,560	(4) 30	465,440	(4) 7.5	4,800	2,432	2,880	(4) 12"	128,780	30-3/4"	9' 1/8"	8' 2-1/4"	17' 2-3/8"
ATWB 24-4N36	96,320	20,010	153,200	(4) 40	505,140	(4) 7.5	4,800	2,432	2,880	(4) 12"	129,420	30-3/4"	9' 1/8"	8' 2-1/4"	17' 2-3/8"
ATWB 24-5L36	108,680	23,100	170,440	(4) 25	424,860	(4) 7.5	4,800	3,021	2,880	(4) 12"	146,660	39-1/4"	9' 8-5/8"	8' 2-1/4"	17' 10-7/8"
ATWB 24-5M36	108,880	23,150	170,640	(4) 30	451,480	(4) 7.5	4,800	3,021	2,880	(4) 12"	146,860	39-1/4"	9' 8-5/8"	8' 2-1/4"	17' 10-7/8"
ATWB 24-5N36	109,520	23,310	171,280	(4) 40	489,990	(4) 7.5	4,800	3,021	2,880	(4) 12"	147,500	39-1/4"	9' 8-5/8"	8' 2-1/4"	17' 10-7/8"
ATWB 24-5O36	109,560	23,320	171,320	(4) 50	521,580	(4) 7.5	4,800	3,021	2,880	(4) 12"	147,540	39-1/4"	9' 8-5/8"	8' 2-1/4"	17' 10-7/8"
ATWB 24-6M36	122,440	26,540	189,120	(4) 30	437,510	(4) 7.5	4,800	3,609	2,880	(4) 12"	165,340	47-3/4"	10' 5-1/8"	8' 2-1/4"	18' 7-3/8"
ATWB 24-6N36	123,080	26,700	189,760	(4) 40	474,830	(4) 7.5	4,800	3,609	2,880	(4) 12"	165,980	47-3/4"	10' 5-1/8"	8' 2-1/4"	18' 7-3/8"
ATWB 24-6O36	123,120	26,710	189,800	(4) 50	505,450	(4) 7.5	4,800	3,609	2,880	(4) 12"	166,020	47-3/4"	10' 5-1/8"	8' 2-1/4"	18' 7-3/8"
ATWB 24-6P36	123,920	26,910	190,600	(4) 60	531,920	(4) 7.5	4,800	3,609	2,880	(4) 12"	166,820	47-3/4"	10' 5-1/8"	8' 2-1/4"	18' 7-3/8"
ATWB 24-7M36	138,120	30,460	209,720	(4) 30	423,550	(4) 7.5	4,800	4,198	2,880	(4) 12"	185,940	47-3/4"	10' 5-1/8"	8' 2-1/4"	18' 7-3/8"
ATWB 24-7N36	138,760	30,620	210,360	(4) 40	459,680	(4) 7.5	4,800	4,198	2,880	(4) 12"	186,580	47-3/4"	10' 5-1/8"	8' 2-1/4"	18' 7-3/8"
ATWB 24-7O36	138,800	30,630	210,400	(4) 50	489,320	(4) 7.5	4,800	4,198	2,880	(4) 12"	186,620	47-3/4"	10' 5-1/8"	8' 2-1/4"	18' 7-3/8"
ATWB 24-7P36	139,600	30,830	211,200	(4) 60	514,940	(4) 7.5	4,800	4,198	2,880	(4) 12"	187,420	47-3/4"	10' 5-1/8"	8' 2-1/4"	18' 7-3/8"

† Model Numbers end in "-Z" for units with Series Flow piping configuration. Series Flow units may require additional coil connections and will require crossover piping. Model numbers will include "C" for units with Stainless Steel coil(s), "R" for units with Low Sound Fan(s) and "S" for units with an option that negates CTI certification.

†† Heaviest section is the coil/fan section.

\* Gallons shown is water in suspension in unit and piping. Allow for additional water in bottom of remote sump to cover pump suction and strainer during operation (12" would normally be sufficient).

▲ When a remote sump arrangement is selected, the spray pump, suction strainer and associated piping are omitted; the unit is provided with an oversized outlet to facilitate drainage to the remote sump.

■ Unit dimensions and coil connections may vary slightly from catalog. See factory certified prints for dimensions, quantity of coil connections, and piping configuration. Coil connections are 4" bevel for weld (BFW). Other connection types such as grooved for mechanical coupling or flanged are also available as options.

# ATWB 24-3L40 to 24-7P40

Selections for ATWB Closed Circuit Coolers are available from EVAPCO's **SPECTRUM™** Program. Please contact your local sales representative for more information on the **SPECTRUM™** program.

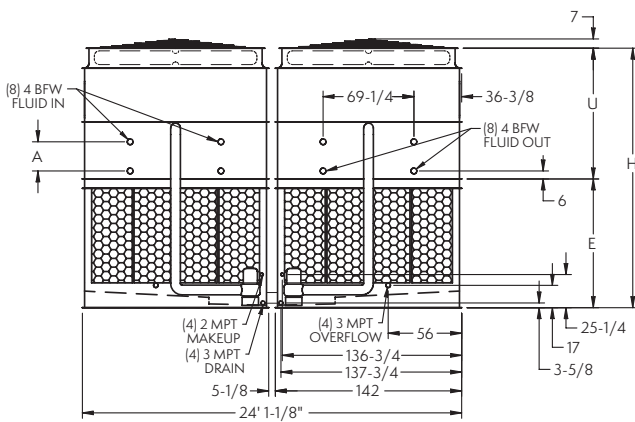
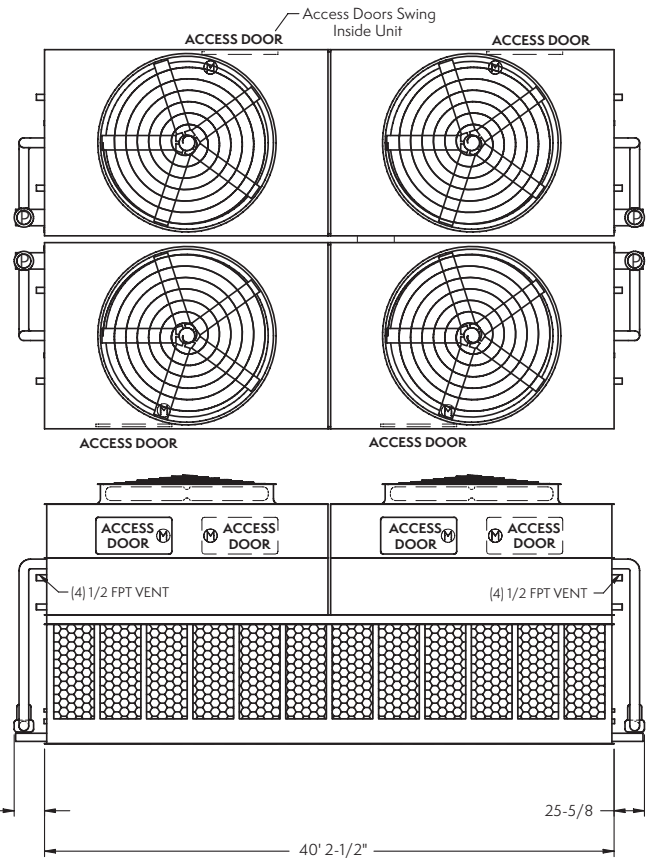

NOTE: The number of coil connections doubles when the flow rate exceeds 3,600 GPM on ATWB 24x40 models. This required option is referred to as the High Flow coil configuration.

ATWB Model Number†	Weights (lbs)			Fans		Spray Pump		Coil Volume (Gallons)	Remote Sump △			Dimensions ■			
	Shipping	Heaviest Section††	Operating	HP	CFM	HP	GPM		Gallons* Required	Conn. Size	Operating Weight (lbs)	Coil A	Upper U	Lower E	Height H
ATWB 24-3L40	89,540	17,850	147,600	(4) 25	499,440	(4) 10	5,600	2,042	3,200	(4) 14"	120,500	22-1/4"	8' 3-5/8"	8' 2-1/4"	16' 5-7/8"
ATWB 24-3M40	89,740	17,900	147,800	(4) 30	530,730	(4) 10	5,600	2,042	3,200	(4) 14"	120,700	22-1/4"	8' 3-5/8"	8' 2-1/4"	16' 5-7/8"
ATWB 24-3N40	90,380	18,060	148,440	(4) 40	579,250	(4) 10	5,600	2,042	3,200	(4) 14"	121,340	22-1/4"	8' 3-5/8"	8' 2-1/4"	16' 5-7/8"
ATWB 24-3O40	90,420	18,070	148,480	(4) 50	616,590	(4) 10	5,600	2,042	3,200	(4) 14"	121,380	22-1/4"	8' 3-5/8"	8' 2-1/4"	16' 5-7/8"
ATWB 24-4L40	104,660	21,630	168,200	(4) 25	484,890	(4) 10	5,600	2,697	3,200	(4) 14"	141,100	30-3/4"	9' 1/8"	8' 2-1/4"	17' 2-3/8"
ATWB 24-4M40	104,860	21,680	168,400	(4) 30	515,270	(4) 10	5,600	2,697	3,200	(4) 14"	141,300	30-3/4"	9' 1/8"	8' 2-1/4"	17' 2-3/8"
ATWB 24-4N40	105,500	21,840	169,040	(4) 40	562,380	(4) 10	5,600	2,697	3,200	(4) 14"	141,940	30-3/4"	9' 1/8"	8' 2-1/4"	17' 2-3/8"
ATWB 24-4O40	105,540	21,850	169,080	(4) 50	598,640	(4) 10	5,600	2,697	3,200	(4) 14"	141,980	30-3/4"	9' 1/8"	8' 2-1/4"	17' 2-3/8"
ATWB 24-5M40	119,580	25,360	188,600	(4) 30	499,820	(4) 10	5,600	3,352	3,200	(4) 14"	161,500	39-1/4"	9' 8-5/8"	8' 2-1/4"	17' 10-7/8"
ATWB 24-5N40	120,220	25,520	189,240	(4) 40	545,510	(4) 10	5,600	3,352	3,200	(4) 14"	162,140	39-1/4"	9' 8-5/8"	8' 2-1/4"	17' 10-7/8"
ATWB 24-5O40	120,260	25,530	189,280	(4) 50	580,680	(4) 10	5,600	3,352	3,200	(4) 14"	162,180	39-1/4"	9' 8-5/8"	8' 2-1/4"	17' 10-7/8"
ATWB 24-5P40	121,060	25,730	190,080	(4) 60	611,090	(4) 10	5,600	3,352	3,200	(4) 14"	162,980	39-1/4"	9' 8-5/8"	8' 2-1/4"	17' 10-7/8"
ATWB 24-6N40	136,820	29,670	211,280	(4) 40	528,630	(4) 10	5,600	4,007	3,200	(4) 14"	184,180	47-3/4"	10' 5-1/8"	8' 2-1/4"	18' 7-3/8"
ATWB 24-6O40	136,860	29,680	211,320	(4) 50	562,720	(4) 10	5,600	4,007	3,200	(4) 14"	184,220	47-3/4"	10' 5-1/8"	8' 2-1/4"	18' 7-3/8"
ATWB 24-6P40	137,660	29,880	212,120	(4) 60	592,190	(4) 10	5,600	4,007	3,200	(4) 14"	185,020	47-3/4"	10' 5-1/8"	8' 2-1/4"	18' 7-3/8"
ATWB 24-7N40	154,540	34,100	234,480	(4) 40	511,760	(4) 10	5,600	4,662	3,200	(4) 14"	207,380	47-3/4"	10' 5-1/8"	8' 2-1/4"	18' 7-3/8"
ATWB 24-7O40	154,580	34,110	234,520	(4) 50	544,760	(4) 10	5,600	4,662	3,200	(4) 14"	207,420	47-3/4"	10' 5-1/8"	8' 2-1/4"	18' 7-3/8"
ATWB 24-7P40	155,380	34,310	235,320	(4) 60	573,290	(4) 10	5,600	4,662	3,200	(4) 14"	208,220	47-3/4"	10' 5-1/8"	8' 2-1/4"	18' 7-3/8"

† Model Numbers end in "-Z" for units with Series Flow piping configuration. Series Flow units require crossover piping. Model numbers will include "C" for units with Stainless Steel coil(s), "R" for units with Low Sound Fan(s) and "S" for units with an option that negates CTI certification.

†† Heaviest section is the coil/fan section.

\* Gallons shown is water in suspension in unit and piping. Allow for additional water in bottom of remote sump to cover pump suction and strainer during operation (12" would normally be sufficient).

△ When a remote sump arrangement is selected, the spray pump, suction strainer and associated piping are omitted; the unit is provided with an oversized outlet to facilitate drainage to the remote sump.

■ Unit dimensions and coil connections may vary slightly from catalog. See factory certified prints for dimensions, quantity of coil connections, and piping configuration. Coil connections are 4" bevel for weld (BFW). Other connection types such as grooved for mechanical coupling or flanged are also available as options.

# Steel Support

## Recommended Steel Support

The recommended support for EVAPCO Closed Circuit Coolers is structural "I" beams located under the outer flanges and running the entire length of the unit. The unit should be elevated to allow access underneath the unit and to the roof below. Mounting holes, 3/4" in diameter are located in the bottom flanges of the pan section to provide for bolting to the structural steel. (Refer to certified drawings from the factory for bolt hole locations.)

Beams should be level before setting the unit in place. Do not level the unit by shimming between the unit and the structural steel. Dimensions, weights, and data are subject to change without notice. Refer to the factory certified drawings for exact dimensions.

**NOTE:** Consult the most recent IBC code for required steel support layout and structural design.

**Plan Views**

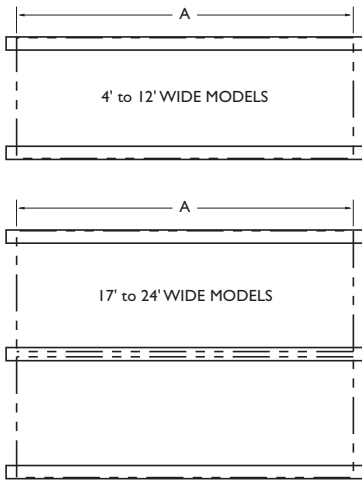

**End Elevations**

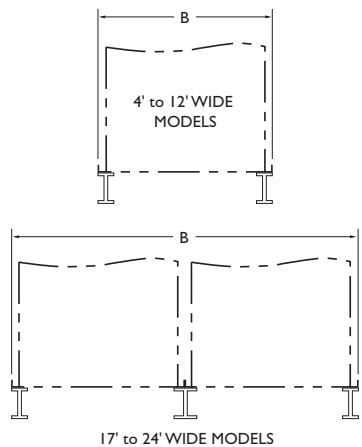

ATWB SUPPORTING STEEL DIMENSIONS		
<b>3' Wide Models</b>	<b>A</b>	<b>B</b>
ATWB 3x3	2' 11-7/8"	3' 1/4"
<b>4' Wide Models</b>	<b>A</b>	<b>B</b>
ATWB 4x4	3' 11-7/8"	4' 1/4"
ATWB 4x6	5' 11-7/8"	4' 1/4"
ATWB 4x9	8' 11-1/2"	4' 1/4"
ATWB 4x12	11' 11-3/4"	4' 1/4"
<b>7' Wide Models</b>	<b>A</b>	<b>B</b>
ATWB 7x9	8' 11-1/2"	7' 4"
ATWB 7x12	11' 11-3/4"	7' 4"
ATWB 7x14	13' 11-3/4"	7' 4"
ATWB 7x18	18' 0"	7' 4"
ATWB 7x24	24' 2"	7' 4"
ATWB 7x28	28' 2"	7' 4"
ATWB 7x36	36' 2-1/2"	7' 4"
<b>8-1/2' Wide Models</b>	<b>A</b>	<b>B</b>
ATWB 9x8	8' 5-1/2"	7' 5-7/8"
ATWB 9x9	8' 11-1/2"	8' 5-1/2"
ATWB 9x11	10' 5-1/2"	8' 5-1/2"
ATWB 9x12	11' 11-3/4"	8' 5-1/2"
ATWB 9x14	13' 11-3/4"	8' 5-1/2"
ATWB 9x18	18' 0"	8' 5-1/2"
ATWB 9x21	21' 0"	8' 5-1/2"
<b>10' Wide Models</b>	<b>A</b>	<b>B</b>
ATWB 10x12	11' 11-3/4"	9' 9-3/4"
ATWB 10x18	18' 0"	9' 9-3/4"
ATWB 10x24	24' 2"	9' 9-3/4"
ATWB 10x36	36' 2-1/2"	9' 9-3/4"
<b>12' Wide Models</b>	<b>A</b>	<b>B</b>
ATWB 12x12	11' 11-3/4"	11' 10"
ATWB 12x14	13' 11-3/4"	11' 10"
ATWB 12x18	18' 0"	11' 10"
ATWB 12x20	20' 0"	11' 10"
ATWB 12x24	24' 2"	11' 10"
ATWB 12x28	28' 2"	11' 10"
ATWB 12x36	36' 2-1/2"	11' 10"
ATWB 12x40	40' 2-1/2"	11' 10"
<b>14' Wide Models</b>	<b>A</b>	<b>B</b>
ATWB 14x9	8' 11-1/2"	15' 1-1/8"
ATWB 14x12	11' 11-3/4"	15' 1-1/8"
ATWB 14x14	13' 11-3/4"	15' 1-1/8"
ATWB 14x18	18' 0"	15' 1-1/8"
<b>17' Wide Models</b>	<b>A</b>	<b>B</b>
ATWB 17x12	11' 11-3/4"	17' 1-1/2"
ATWB 17x14	13' 11-3/4"	17' 1-1/2"
<b>20' Wide Models</b>	<b>A</b>	<b>B</b>
ATWB 20x12	11' 11-3/4"	20' 5/8"
ATWB 20x18	18' 0"	20' 5/8"
ATWB 20x24	24' 1-3/4"	20' 5/8"
ATWB 20x36	36' 2-1/4"	20' 5/8"
<b>24' Wide Models</b>	<b>A</b>	<b>B</b>
ATWB 24x12	11' 11-3/4"	24' 1-1/8"
ATWB 24x14	13' 11-3/4"	24' 1-1/8"
ATWB 24x18	18' 0"	24' 1-1/8"
ATWB 24x20	20' 0"	24' 1-1/8"
ATWB 24x24	24' 2"	24' 1-1/8"
ATWB 24x28	28' 2"	24' 1-1/8"
ATWB 24x36	36' 2-1/2"	24' 1-1/8"
ATWB 24x40	40' 2-1/2"	24' 1-1/8"









-  World Headquarters  
Research & Development Center
-  EVAPCO Manufacturing Facilities

## EVAPCO, Inc. — World Headquarters & Research / Development Center

P.O. Box 1300 • Westminster, MD 21158 USA  
410.756.2600 • [marketing@evapco.com](mailto:marketing@evapco.com) • [evapco.com](http://evapco.com)

### North America

-  **EVAPCO, Inc.**  
**World Headquarters**  
Westminster, MD USA  
410.756.2600  
[marketing@evapco.com](mailto:marketing@evapco.com)
-  **EVAPCO East**  
Taneytown, MD USA
-  **EVAPCO East**  
Key Building  
Taneytown, MD USA
-  **EVAPCO Midwest**  
Greenup, IL USA  
217.923.3431  
[evapcomw@evapcomw.com](mailto:evapcomw@evapcomw.com)
-  **Evapcold Manufacturing**  
Greenup, IL USA
-  **EVAPCO West**  
Madera, CA USA  
559.673.2207  
[contact@evapcowest.com](mailto:contact@evapcowest.com)
-  **EVAPCO Alcoil, Inc.**  
York, PA USA  
717.347.7500  
[info@evapco-alcoil.com](mailto:info@evapco-alcoil.com)
-  **EVAPCO Iowa**  
Lake View, IA USA
- EVAPCO Iowa**  
Sales & Engineering  
Medford, MN USA  
507.446.8005  
[evapcomn@evapcomn.com](mailto:evapcomn@evapcomn.com)

-  **EVAPCO LMP ULC**  
Laval, Quebec, Canada  
450.629.9864  
[info@evapcolmp.ca](mailto:info@evapcolmp.ca)
-  **EVAPCO Select Technologies, Inc.**  
Belmont, MI USA  
844.785.9506  
[emarketing@evapcoselect.com](mailto:emarketing@evapcoselect.com)
-  **Refrigeration Vessels & Systems Corporation**  
Bryan, TX USA  
979.778.0095  
[rvs@rvscorp.com](mailto:rvs@rvscorp.com)
-  **Tower Components, Inc.**  
Ramseur, NC USA  
336.824.2102  
[mail@towercomponentsinc.com](mailto:mail@towercomponentsinc.com)
-  **EvapTech, Inc.**  
Edwardsville, KS USA  
913.322.5165  
[marketing@evaptech.com](mailto:marketing@evaptech.com)
- EVAPCO Dry Cooling, Inc.**  
Bridgewater, NJ USA  
908.379.2665  
[info@evapcodc.com](mailto:info@evapcodc.com)
- EVAPCO Dry Cooling, Inc.**  
Littleton, CO USA  
908.895.3236  
[info@evapcodc.com](mailto:info@evapcodc.com)
- EVAPCO Power México S. de R.L. de C.V.**  
Mexico City, Mexico  
[52] 55.8421.9260  
[info@evapcodc.com](mailto:info@evapcodc.com)

### Asia Pacific

-  **EVAPCO Asia Pacific Headquarters**  
Baoshan Industrial Zone Shanghai, P.R. China  
(86) 21.6687.7786  
[marketing@evapcochina.com](mailto:marketing@evapcochina.com)
-  **EVAPCO (Shanghai) Refrigeration Equipment Co., Ltd.**  
Baoshan Industrial Zone, Shanghai, P.R. China
-  **EVAPCO (Beijing) Refrigeration Equipment Co., Ltd.**  
Huairou District, Beijing, P.R. China  
(86) 10.6166.7238  
[marketing@evapcochina.com](mailto:marketing@evapcochina.com)
-  **EVAPCO Air Cooling Systems (Jiaxing) Company, Ltd.**  
Jiaxing, Zhejiang, P.R. China  
(86) 573.8311.9379  
[info@evapcochina.com](mailto:info@evapcochina.com)
-  **EVAPCO Australia (Pty.) Ltd.**  
Riverstone, NSW, Australia  
(61) 02.9627.3322  
[sales@evapco.com.au](mailto:sales@evapco.com.au)
- EvapTech (Shanghai) Cooling Tower Co., Ltd**  
Baoshan District, Shanghai, P.R. China.  
Tel: (86) 21.6478.0265
- EvapTech Asia Pacific Sdn. Bhd.**  
Puchong, Selangor, Malaysia  
(60) 3.8070.7255  
[marketing-ap@evaptech.com](mailto:marketing-ap@evaptech.com)

### Europe | Middle East | Africa

-  **EVAPCO Europe EMENA Headquarters**  
Tongeren, Belgium  
(32) 12.39.50.29  
[evapco.europe@evapco.be](mailto:evapco.europe@evapco.be)
-  **EVAPCO Europe BV**  
Tongeren, Belgium
-  **EVAPCO Europe, S.r.l.**  
Milan, Italy  
(39) 02.939.9041  
[evapcoeuropa@evapco.it](mailto:evapcoeuropa@evapco.it)
-  **EVAPCO Europe, S.r.l.**  
Sondrio, Italy
-  **EVAPCO Europe A/S**  
Aabybro, Denmark  
(45) 9824.4999  
[info@evapco.dk](mailto:info@evapco.dk)
- EVAPCO Europe GmbH**  
Meerbusch, Germany  
(49) 2159.69560  
[info@evapco.de](mailto:info@evapco.de)
- EVAPCO Middle East DMCC**  
Dubai, United Arab Emirates  
(971) 56.991.6584  
[info@evapco.ae](mailto:info@evapco.ae)
-  **Evap Egypt Engineering Industries Co.**  
A licensed manufacturer of EVAPCO, Inc.  
Nasr City, Cairo, Egypt  
(20) 10.05.432198  
[evapco@iba-group.com](mailto:evapco@iba-group.com)
-  **EVAPCO S.A. (Pty.) Ltd.**  
A licensed manufacturer of EVAPCO, Inc.  
Isando, South Africa  
(27) 11.392.6630  
[evapco@evapco.co.za](mailto:evapco@evapco.co.za)

### South America

-  **EVAPCO Brasil**  
Equipamentos Industriais Ltda.  
Indaiatuba, São Paulo, Brazil  
(55) 11.5681.2000  
[vendas@evapco.com.br](mailto:vendas@evapco.com.br)
-  **FanTR Technology Resources**  
Itu, São Paulo, Brazil  
(55) 11.4025.1670  
[fantr@fantr.com](mailto:fantr@fantr.com)