

UNIT	ED CIRCUIT CC	
MODEL #	LRWB 5-7L12	SCALE NTS



DWG. #	WV051214-DRD-ST	REV.	-
SERIAL #		DATE	11/2/2024

- NOTES:
1. (M)- FAN MOTOR LOCATION
 2. MPT DENOTES MALE PIPE THREAD
FPT DENOTES FEMALE PIPE THREAD
BFW DENOTES BEVELED FOR WELDING
GVD DENOTES GROOVED
FLG DENOTES FLANGE
PE DENOTES PLAIN END
 3. +UNIT WEIGHT DOES NOT INCLUDE ACCESSORIES (SEE ACCESSORY DRAWINGS)
 4. 3/4" [19mm] DIA. MOUNTING HOLES. REFER TO RECOMMENDED STEEL SUPPORT DRAWING
 5. DIMENSIONS LISTED AS FOLLOWS: ENGLISH FT IN [METRIC] [mm]
 6. * - APPROXIMATE DIMENSIONS DO NOT USE FOR PRE-FABRICATION OF CONNECTING PIPING
 7. MAKE-UP WATER PRESSURE
20 psi [137 kPa] MIN, 50 psi [344 kPa] MAX

FACE B
PLAN VIEW

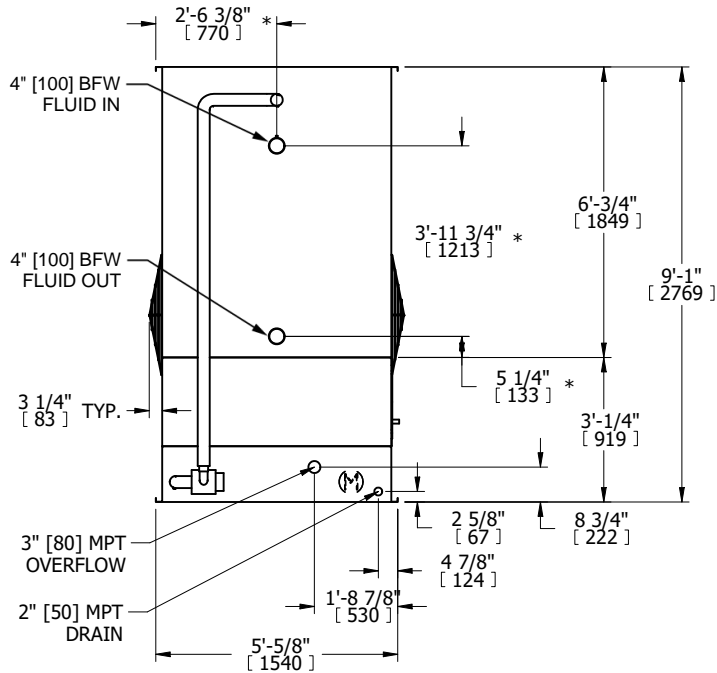
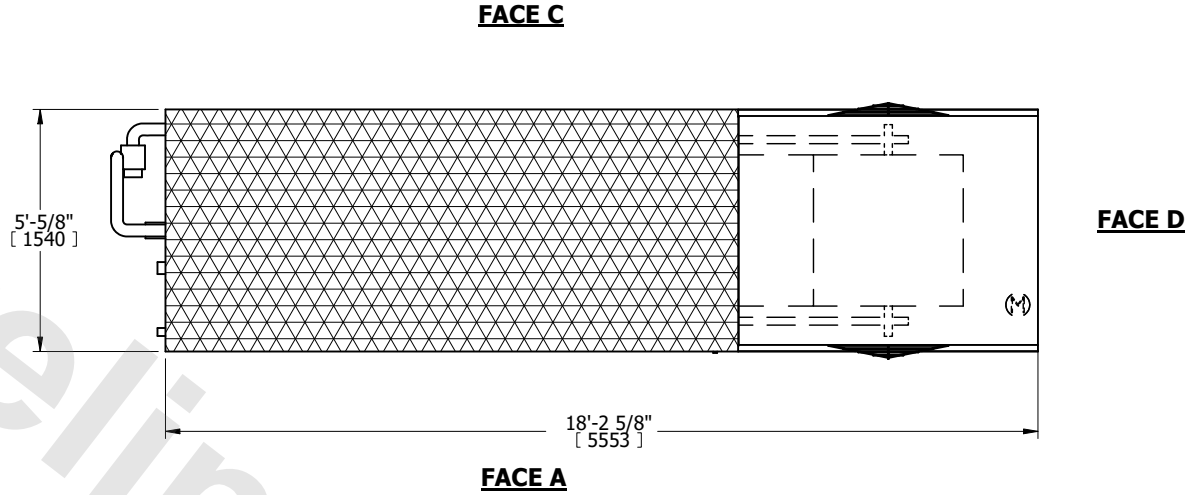

FACE B

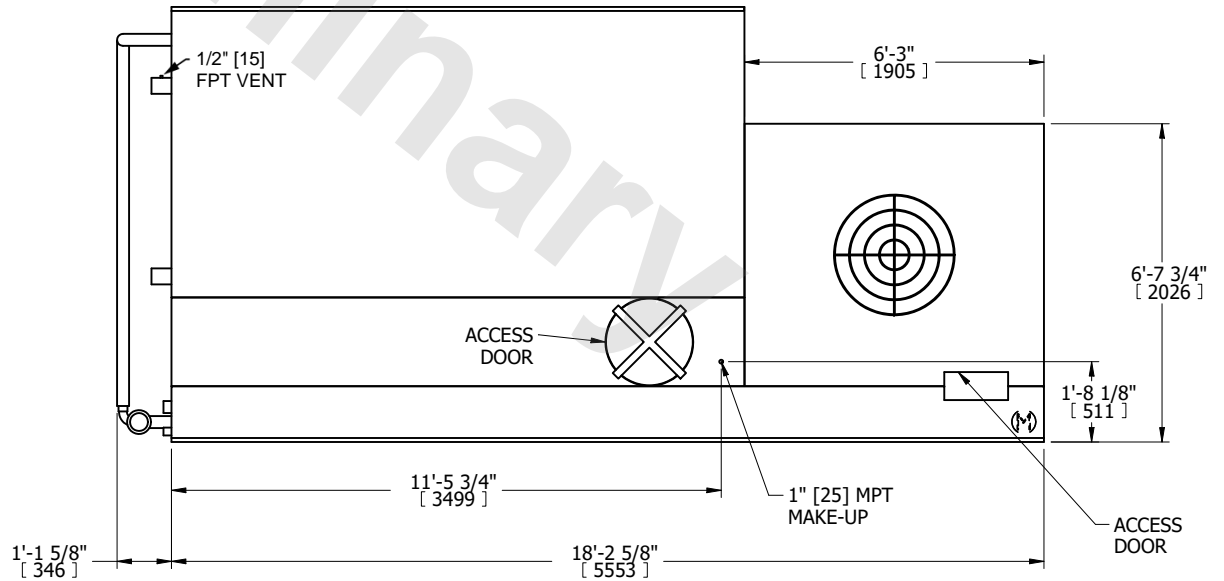

FACE A

SHIPPING WEIGHT	140 lbs+ [4600] †	OPERATING WEIGHT	30 lbs+ [7275] †	HEAVIEST SECTION WEIGHT	140 lbs+ [4600] †	NO. OF SHIPPING SECTIONS	1	DRAWN BY:	TLS
-----------------	-------------------	------------------	------------------	-------------------------	-------------------	--------------------------	---	-----------	-----