

EVAPCO, INC.



| | | | | | | |
|--------------------------|---------------------------------|------------------------|----------------------------------|------------------|--------------------------|----------|
| UNIT CONDENSER | MODEL # eco-ATC-1377A | SCALE N.T.S. | DWG. # EG241806-DRA-ST | REV. - | DATE 11/4/2024 | SERIAL # |
|--------------------------|---------------------------------|------------------------|----------------------------------|------------------|--------------------------|----------|

- NOTES:
- (M)- FAN MOTOR LOCATION
 - HEAVIEST SECTION IS UPPER SECTION
 - MPT DENOTES MALE PIPE THREAD
FPT DENOTES FEMALE PIPE THREAD
BFW DENOTES BEVELED FOR WELDING
 - +UNIT WEIGHT DOES NOT INCLUDE ACCESSORIES (SEE ACCESSORY DRAWINGS)
 - MAKE-UP WATER PRESSURE
20 psi MIN [137 kPa], 50 psi MAX [344 kPa]
 - * -APPROXIMATE DIMENSIONS DO NOT USE FOR PRE-FABRICATION OF CONNECTING PIPING
 - VENT PROVIDED ON CLOSED CIRCUIT COOLERS ONLY

Preliminary

**FACE 2
PLAN VIEW**

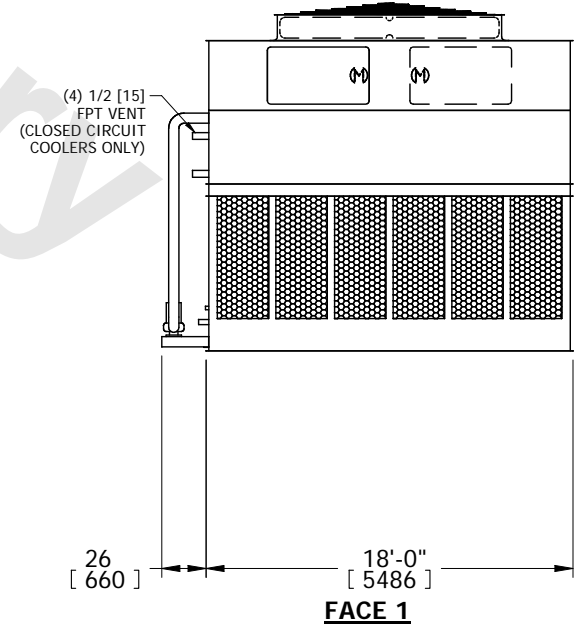
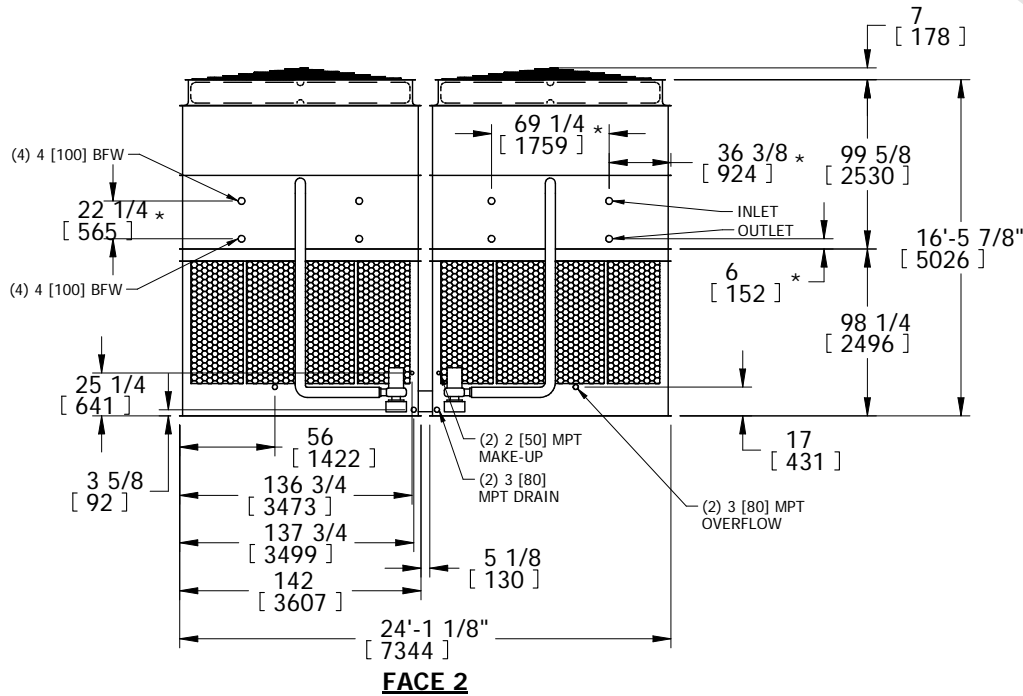
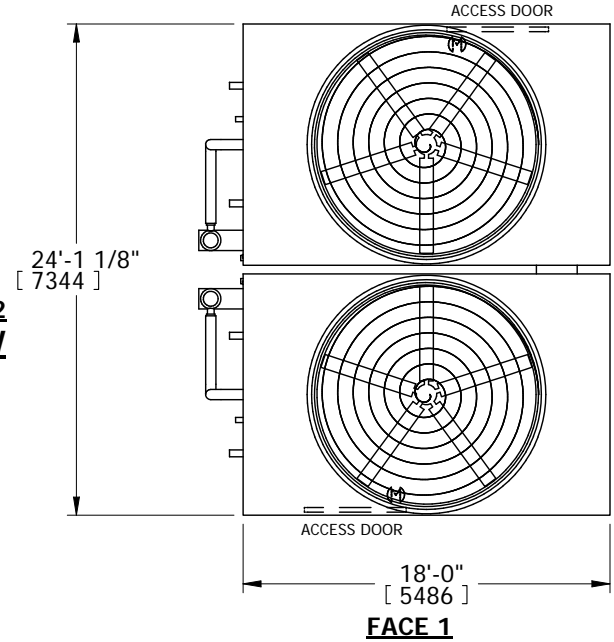

| | | | |
|--|---|---|--------------------------------------|
| SHIPPING WEIGHT 48760 lbs+ [22120] kg+ | OPERATING WEIGHT 68680 lbs+ [31155] kg+ | HEAVIEST SECTION WEIGHT 20460 lbs+ [9285] kg+ | NO. OF SHIPPING SECTIONS 4 |
|--|---|---|--------------------------------------|