

|         |               |           |
|---------|---------------|-----------|
| UNIT    | COOLING TOWER |           |
| MODEL # | AT 17-2G9     | SCALE NTS |

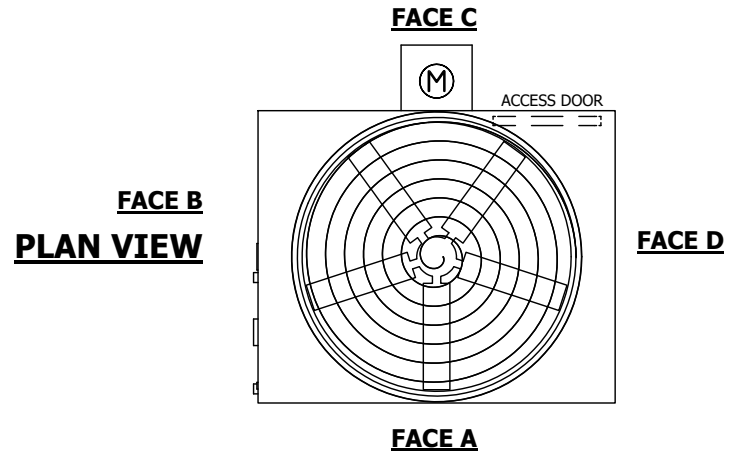

|          |                   |      |           |
|----------|-------------------|------|-----------|
| DWG. #   | CT4C070924-DRA-ST | REV. | -         |
| SERIAL # |                   | DATE | 3/13/2025 |

- NOTES:
- (M)- FAN MOTOR LOCATION
  - HEAVIEST SECTION IS FAN/CASING SECTION
  - MPT DENOTES MALE PIPE THREAD  
FPT DENOTES FEMALE PIPE THREAD  
BFW DENOTES BEVELED FOR WELDING  
GVD DENOTES GROOVED  
FLG DENOTES FLANGE
  - +UNIT WEIGHT DOES NOT INCLUDE ACCESSORIES (SEE ACCESSORY DRAWINGS)
  - 3/4" [19MM] DIA. MOUNTING HOLES. REFER TO RECOMMENDED STEEL SUPPORT DRAWING
  - DIMENSIONS LISTED AS FOLLOWS:  
ENGLISH FT-IN  
[METRIC] [mm]
  - MAKE-UP WATER PRESSURE  
20 psi MIN [137 kPa], 50 psi MAX [344 kPa]



|                 |                      |                  |                      |                         |                      |                          |   |           |     |
|-----------------|----------------------|------------------|----------------------|-------------------------|----------------------|--------------------------|---|-----------|-----|
| SHIPPING WEIGHT | 3920 lbs+ [1780] kg+ | OPERATING WEIGHT | 6430 lbs+ [2920] kg+ | HEAVIEST SECTION WEIGHT | 2560 lbs+ [1165] kg+ | NO. OF SHIPPING SECTIONS | 2 | DRAWN BY: | MBG |
|-----------------|----------------------|------------------|----------------------|-------------------------|----------------------|--------------------------|---|-----------|-----|