

# EVAPORATIVE CONDENSERS

## ATC-E

### ADVANCED TECHNOLOGY CONDENSER



Available with Optional  
304L or 316L Stainless Steel

**TITAN COIL**

Available with Optional

**evapco**  
WATER SYSTEMS

Available in Capacities from 35 to 2,637 Ammonia Tons!

**evapco**® for LIFE



**GLOBAL COLD CHAIN**  
ALLIANCE®

Member of  
**iiar**  
International Institute of  
Ammonia Refrigeration  
www.iiar.org

**AHRI** Air-Conditioning, Heating,  
and Refrigeration Institute

# ATC-E Design and Construction Features

The ATC-E line of evaporative condensers reflects EVAPCO's continuing commitment to research and development. The advanced design provides owners with many operational and performance advantages. The owner-oriented features of the ATC-E along with the independent certification of IBC compliance reinforce the ATC's position as the premier induced draft evaporative condenser for the industrial refrigeration industry.



## PVC Spray Distribution Header with ZM<sup>®</sup> II Nozzles

- Large orifice nozzles prevent clogging (no moving parts).
- Redesigned nozzles for superior water distribution.
- Nozzles are threaded into header at proper orientation.
- Fixed position nozzles require zero maintenance.
- Threaded end caps for ease of cleaning.
- Guaranteed for life.

## Thermal-Pak<sup>®</sup> II Heat Transfer Technology

- More surface area per plan area than competitive designs.
- Improved heat transfer efficiency due to tube geometry and orientation.
- Lower refrigerant charge.

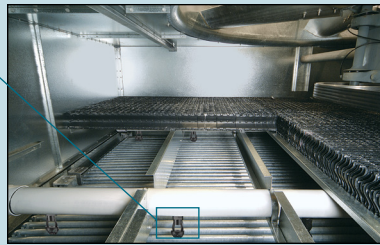

## Water Saver Drift Eliminators

- Patented design reduces drift rate to 0.001%.
- Made from corrosion resistant PVC for long life.

U.S. Patent No. 6,315,804



## Non-Chemical Water Treatment (Optional)

- Scale, corrosion and bacteria control.
- Factory mounted with single source responsibility.
- Environmentally safe, chemical-free water treatment.

U.S. Patent No. 7,704,364



## Solid Chemistry Water Treatment (Optional)

- Controlled release chemistry provides uniform treatment over a 30 day period.
- Factory mounted and wired.
- Easier and safer; eliminates the potential for liquid spills.

U.S. Patent No. 8,398,850

## Totally Enclosed Pump Motors

- Help assure long, trouble-free operation.



## Stainless Steel Strainer

- Resists corrosion better than other materials.

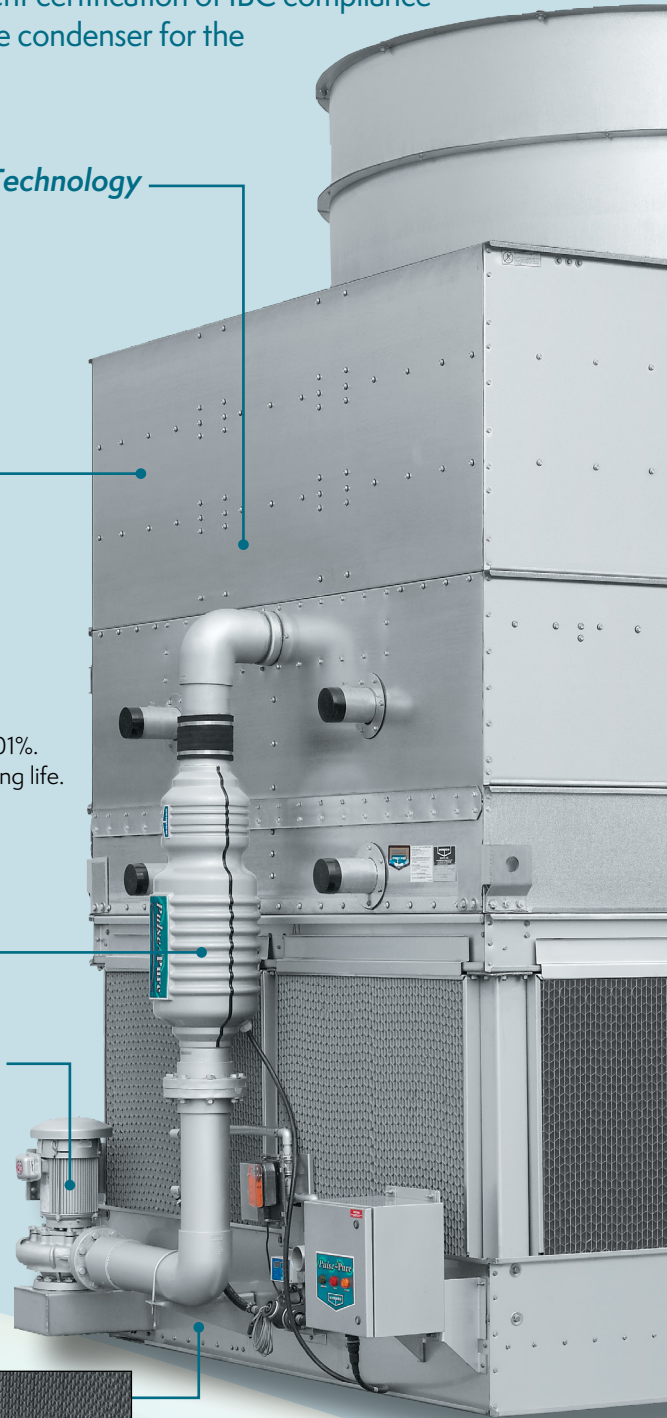

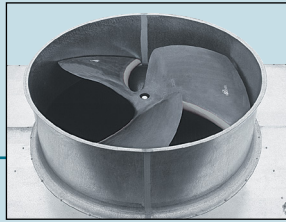

### Super Low Sound Fan (Optional)

- 9-15 dB(A) sound reduction.
- Extremely wide chord fan blades for sound sensitive applications.
- One piece molded heavy duty construction.

### G-235 Mill Hot-Dip Galvanized Steel Construction

(Stainless steel available as affordable option)

### Advanced Drive System Design

- Totally Enclosed Fan Motors assures Long Life.
- Power-Band Belts for Better Lateral Rigidity.
- Advanced Design Aluminum Fan Blades.
- Non-corroding Cast Aluminum Sheaves.
- Heavy-Duty Fan Shaft Bearings with L-10 Life of 75,000 - 135,000 hrs.
- All Other Components are of Corrosion Resistant Materials.
- All Components Covered by 5 Year Warranty.



### Easy to Service Motor Mount Design

- All normal maintenance can be performed quickly from outside the unit.
- Designed for easy belt adjustment.
- Extended lube lines for easy bearing lubrication.
- If required, motor may swing to outside for easy removal.



### Unique Field Seam

- Eliminates up to 66% of fasteners.
- Self-guiding channels improve quality of field seam to eliminate leaks.
- Easy to install.
- Lower installation cost.

### Air Inlet Access Door (Optional)

- Increased ease of access to basin.
- Hinged access panel with quick release mechanism.
- Not available on all models.

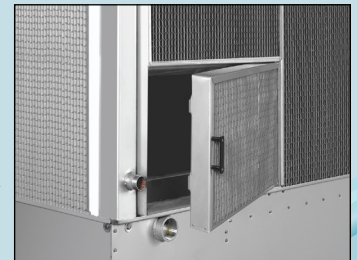

### WST Air Inlet Louvers (Water and Sight Tight)

- Easily removable for access.
- Design keeps sunlight out – preventing biological growth.
- Keeps water in while keeping dirt and debris out.

U.S. Patent No. 7,972,196

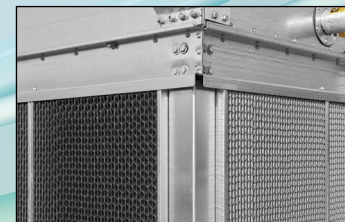

### "Clean Pan" Basin Design

- Access from all four sides.
- Large open area simplifies maintenance.
- Basin may be inspected with pumps running.
- Sloped basin design prevents sediment buildup, biological film and standing water.



# ATC-E Design Features

Proven Performance and Design Flexibility



## About EVAPCO

Evapco is the global innovator in heat transfer solutions. Our pledge is to make everyday life easier, more comfortable, more reliable, and more sustainable for people everywhere. With manufacturing facilities and sales offices in more than 50 countries and 48 active US patents —we are the team that engineers and contractors know they can count on for life.

## Contact

your local Evapco Representative  
or visit [evapco.com](http://evapco.com) to learn more.

## Thermal-Pak® II Coil

EVAPCO'S Thermal-Pak® II condensing coils are designed for maximum heat transfer efficiency. This unique coil design utilizes counterflow heat transfer. The rows of elliptical tubes are staggered and angled in the direction of airflow to enhance air turbulence, thereby increasing heat transfer while minimizing airside pressure drop.

The design features of EVAPCO'S Thermal-Pak® II condensing coils ensure the end user will receive the best evaporative heat transfer efficiency.

These characteristics, and other engineering advancements of the Thermal-Pak® II, have been proven in EVAPCO'S world-class research and development laboratory resulting in the following end user benefits:

- Lower Operating Refrigerant Charge
- Low Power Consumption Per Ton
- Lower Operating Weight
- Small Plan Area Per Ton

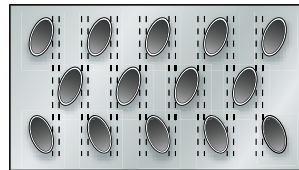

Thermal-Pak® II Coil by EVAPCO

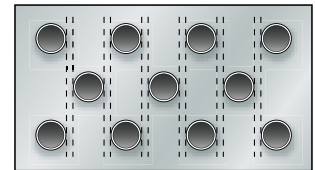

Round Tube Coil by Others

The coils are manufactured from high quality carbon steel tubing following the most stringent quality control procedures and in accordance with the ANSI/ASME B31.5 Refrigerant Piping Code. Each circuit is inspected to assure the material quality and then tested before being assembled into a coil. Each circuit is then assembled into a complete coil with a design pressure of 300 psig (optional design pressure of 400 psig is available). Finally, the assembled coil is strength tested in accordance with ASME B31.5 and subsequently leak tested using air under water.

To protect the coil against corrosion, it is placed in a heavy-duty steel frame and the entire assembly is dipped in molten zinc (hot dip galvanized) at a temperature of approximately 800°F.

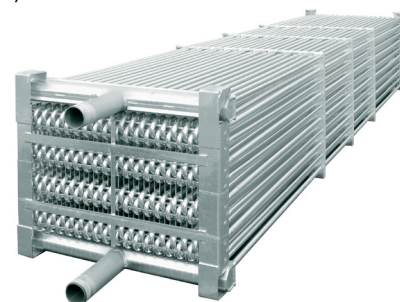

Thermal-Pak® II Coil

# ATC-E Design Features

## Design Features

The ATC-E line of induced draft evaporative condensers reflects EVAPCO's continuing commitment to research and development. The advanced design provides owners with many operational and performance advantages. The owner-oriented features of the ATCE, along with the independent certification of IBC compliance, reinforce the ATC's position as the premier induced draft evaporative condenser for the industrial refrigeration industry.

### G-235 Mill Hot-Dip Galvanized Steel Construction

Mill hot-dip galvanized steel has been successfully used for over 40 years for the protection of evaporative condensers against corrosion. There are various grades of mill galvanized steel each with differing amounts of zinc protection. EVAPCO has been a leader in the industry in developing heavier galvanizing, and was the first to standardize on G-235 mill hot-dip galvanized steel.

G-235 designation means there is a minimum of 2.35 ounces of zinc per square foot of surface area as measured in a triple spot test. G-235 is the heaviest level of galvanizing available for manufacturing evaporative condensers and has a minimum of 12% more zinc protection than competitive designs using G-210 steel.

During fabrication, all panel edges are coated with a 95% pure zinc-rich compound for extended corrosion resistance.

### Type 304 Stainless Steel Strainers

Subjected to excessive wear and corrosion, the sump strainer is critical to the successful operation of the condenser. EVAPCO uses only stainless steel for this very important component.

### Unique Seam Design—Eliminate Field Leaks

The ATC-E features EVAPCO's unique panel construction design which includes a special butyl tape sealer. Each joint is then backed with a secondary caulking compound and encased in a double-brake flange for added strength and structural integrity. This unique sealing system has been proven effective in both laboratory tests and years of field application.

## Improved Maintenance

### ZM® II Spray Nozzle Water Distribution System

A consistent water distribution is paramount for reliable, scale-free evaporative condensing. EVAPCO's Zero Maintenance ZM® II Spray Nozzle remains clog-free under the toughest conditions to deliver approximately 6 GPM to every square foot of coil plan area.

The heavy-duty ABS ZM® II Spray Nozzles have a 1-1/4" diameter opening and a 1-1/4" splash plate clearance.

The fixed position ZM® II Spray Nozzles are mounted in corrosion-free PVC water distribution pipes that have threaded end caps. Together, these elements combine to provide unequalled coil coverage, enhanced droplet formation and make the industries best performing maintenance-free water distribution system.



ZM® II Nozzle

## Alternate Materials of Construction

EVAPCO induced draft condensers have a modular design which allows for specific areas to be enhanced for increased corrosion protection. For particularly corrosive environments, EVAPCO condensers are available with stainless steel construction for the basin, casing and/or coil.

### Stainless Steel Basin

The basin area of a condenser is often subjected to high concentrations of impurities and silt. EVAPCO offers optional stainless steel construction for superior corrosion resistance. This option provides Type 304 or Type 316 stainless steel for the entire basin section - including the support columns and air inlet louver frames.

### Stainless Steel Casing

EVAPCO offers optional stainless steel construction for superior corrosion resistance on various casing panel configurations including water touch basin, water touch unit, and all stainless steel panel construction. These options are available in Type 304 or Type 316 stainless steel for improved corrosion protection and jobsite requirement flexibility.

### Stainless Steel Coils

The heat exchanger coil is the heart of the evaporative condenser. For this critical component, EVAPCO offers the options of Type 304L or Type 316L stainless steel construction using the patented Thermal Pak® II coil design. Highly efficient

# ATC-E Induced Draft Axial Fan Design Features

## Belt Drive Units - 4' through 8-1/2' Wide Models and Multi-Cell Arrangements

### ATC-50E to ATC-926E

The fan motor and drive assembly on these units is designed to allow easy servicing of the motor and **adjustment of the belt tension from the exterior of the unit**. A TEFC fan motor is mounted on the outside of these models. A protective cover swings away to allow servicing and belt adjustment. A large, hinged access door with a "quick release" latch provides access to the fan section for maintenance. (Not available on 4' Wide Models)



4' External Belt Driven Motor Mount



7' through 8-1/2' and multi-cell arrangements  
External Motor Mount (with optional ladder)

## Belt Drive Units - 10' and 12' Wide Models and Multi-Cell Arrangements

### ATC-XE298E to ATC-XC1340E

### ATC-428E to ATC-3714E

The fan motor and drive assembly is designed to allow easy **servicing of the motor and adjustment of the belt tension from the exterior of the unit**. The TEAO fan motor is located inside the fan casing on a rugged, heavy-duty motor base. The innovative motor base also features a unique locking mechanism for a positive adjustment.

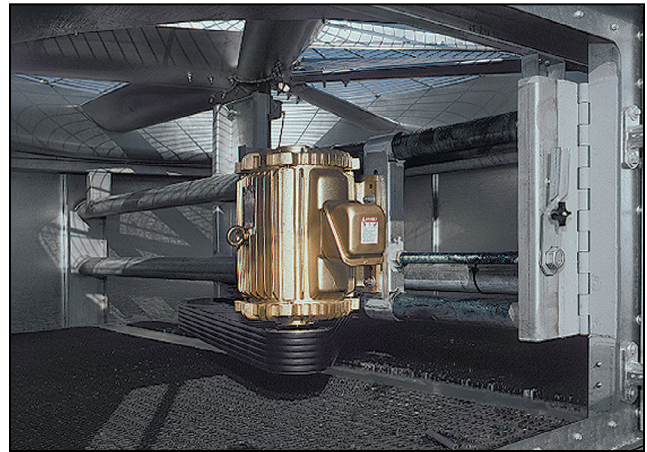

Motor Base Assembly

The motor base is designed to swing out through a very large, 14 square foot access opening. This allows for easy servicing of the motor.

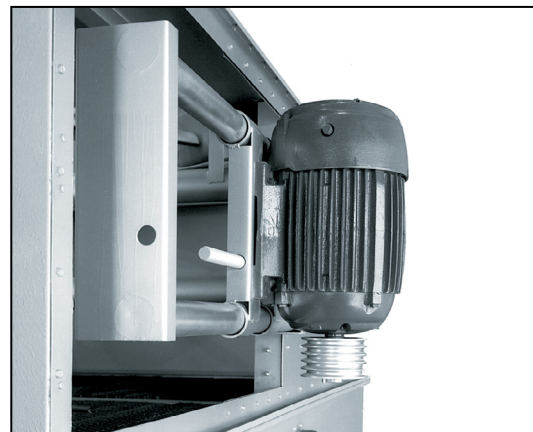

Motor Access

# ATC-E Design Features

## Drive System

**Inverter Duty Motors:** Inverter Duty Motors are standard on ATC-E condensers. Inverter Duty motors are totally enclosed premium efficiency and inverter capable (VFD by others).

**Note: Variable Frequency Drive control may require other component modification such as motor shaft grounding brushes, AC load reactors, low pass filters and tuned trap filters to ensure proper motor performance and service life.**

**Power- Band Drive Belt:** The Power-Band is a solid-back, multigroove belt system that has high lateral rigidity. The proven drive system is used on 8' wide and wider models. The belt is constructed of neoprene with polyester cords. The drive belt is designed for a minimum 150% of the motor nameplate horsepower for long life and durability.

**Fan Shaft Bearings:** The fan shaft bearings in ATC-E units are specially selected for long, trouble-free life. They are rated for an L-10 life of 75,000 to 135,000 hours and are the heaviest pillow block bearing available.

**Aluminum Alloy Sheaves:** Fan sheaves are constructed of corrosion-free aluminum for long life, eliminating the corrosion that exists on cast steel sheaves, thereby extending belt life.

**Five Year Drive Warranty: All drive components on ATC-E units are covered by Evapco's exclusive 5 year drive warranty - including fan motors and belts!**

## Superior Water Saving Drift Eliminators

An extremely efficient drift eliminator system is standard on EVAPCO condensers. The patented system removes entrained water droplets from the air stream to limit the drift rate to less than 0.001% of the recirculating water rate. The drift eliminators are constructed of an inert polyvinyl chloride (PVC) plastic material which effectively eliminates corrosion of these vital components. They are assembled in sections to facilitate easy removal for inspection of the water distribution system.



*Water Saving Drift Eliminator*

## Superior WST Air Inlet Louver Design

EVAPCO's WST Inlet Louvers keep water in and sunlight out of the basins of induced draft products. The unique non-planar design is made from light-weight PVC sections which easily fit together and have no loose hardware, enabling easy basin access.

Developed with computational fluid dynamics (CFD) software and tested in EVAPCO's R&D center, the louver's air channels are optimized to maintain fluid dynamic and thermodynamic efficiency, and block all line-of-sight paths into the basin eliminating splash-out; even when the fans are off. Additionally, algae growth is minimized by blocking all sunlight.



*Inlet Louver Design*

The combination of easy basin access, no splash-out, and minimized algae growth, saves the end user money on maintenance hours, water consumption and water treatment costs.

## "Clean Pan" Basin Design

EVAPCO ATC-E condensers feature a sloped basin from the upper to lower pan section. This "Clean Pan" design allows the water to be completely drained from the basin. The

condenser water will drain from the upper section to

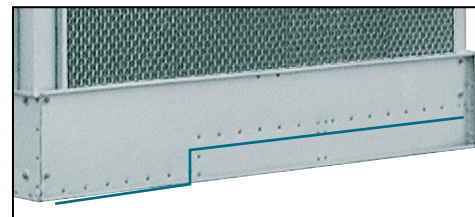

the depressed lower pan section where the dirt and debris can be easily flushed out through the drain. This design helps prevent buildup of sedimentary deposits, biological films and minimizes standing water.

## Air Inlet Access Door (Optional)

To aid in basin maintenance, ATC-E models can be equipped with an optional air inlet access door. This feature improves the maintainability of the condenser by allowing easy access to the make-up float assembly and strainer for inspection without removing an entire inlet louver. Air inlet access doors are not available on models ATC-50E to ATC-165E.



# ATC-E Selection Procedure

Two methods of selection are presented. The first is based on the total heat of rejection as described immediately below. The second, and more simple method, is based on evaporator tons. The evaporator ton method is only applicable to systems with open-type reciprocating compressors.

The heat of rejection method is applicable to all but centrifugal compressor applications and is normally used for selecting evaporative condensers for use with hermetic compressors and screw

compressors. It can also be used for standard open-type reciprocating compressors as an alternate to the evaporator ton method.

The evaporator ton method is based on the estimated heat of compression. **The heat of rejection method of selection is more accurate and should be used whenever possible.**

Refer to the factory for selections on systems with centrifugal compressors.

## Heat of Rejection Method

In the heat of rejection method, a factor for the specified operating conditions (condensing temperature and wet bulb) is obtained from Table 1 or 2 and multiplied by the heat of rejection.

The resultant figure is used to select a unit from Table 3. Unit capacities are given in Table 3 in thousands of BTU/Hr or MBH.

If the heat of rejection is not known, it can be determined by one of the following formulas:

### Open Compressors:

$$\text{Heat of Rejection} = \text{Evaporator Load (BTU/Hr)} + \text{Compressor BHP} \times 2545$$

### Hermetic Compressors:

$$\text{Heat of Rejection} = \text{Evaporator Load (BTU/Hr)} + \text{K.W. Compressor Input} \times 3415$$

### EXAMPLE

Given: 450 ton load, ammonia refrigerant 96.3° condensing temperature, 78° W.B. temperature and 500 compressor BHP.

Selection: Heat of Rejection

$$\begin{aligned} 450 \text{ tons} \times 12000 &= 5,400,000 \text{ BTU/Hr} \\ 500 \text{ BHP} \times 2545 &= 1,272,500 \text{ BTU/Hr} \\ \text{Total} &= 6,672,500 \text{ BTU/Hr} \end{aligned}$$

From Table 2, the capacity factor for 96.3° condensing and 78° W.B. = 1.37  $6,672,500 \times 1.37 = 9,141,325 \text{ BTU/Hr}$  or 9142 MBH. Therefore, select a model ATC-639E or ATC-XC641E.

**Note:** For screw compressor selections employing water-cooled oil cooling, select a condenser for the total MBH as in the example. The condenser can then function in one of two ways:

- (1) Recirculating water from the water sump can be used for oil cooling. A separate pump should be employed and the return water should be directed into the water sump at the opposite end from the pump suction.
- (2) The condenser coil can be circuited so that water or a glycol-water mixture for the oil cooler can be cooled in a separate section of the coil. Specify load and water flow required.

For refrigerant injection cooled screw compressors, select the condenser in the same manner as shown in the example.

If the oil cooler is supplied by water from a separate source, then the oil cooling load should be deducted from the heat of rejection before making the selection.

**Table 1 - Ammonia (R-717) Heat Rejection Factors**

Condensing Pres. psig	Cond Temp. °F	Wet Bulb Temperature, (°F)																	
		50	55	60	62	64	66	68	70	72	74	75	76	77	78	80	82	84	86
152	85	.98	1.09	1.24	1.34	1.44	1.56	1.72	1.90	2.16	2.48	2.70	2.94	3.25	3.57	-	-	-	-
166	90	.83	.91	1.02	1.08	1.14	1.21	1.29	1.40	1.53	1.69	1.79	1.89	2.01	2.12	2.54	3.12	-	-
181	95	.71	.78	.85	.89	.94	.98	1.03	1.09	1.17	1.25	1.29	1.34	1.39	1.47	1.63	1.85	2.12	2.47
185	96.3	.69	.75	.82	.86	.90	.94	.98	1.03	1.10	1.18	1.22	1.26	1.31	1.37	1.51	1.71	1.94	2.25
197	100	.63	.68	.73	.76	.79	.81	.84	.87	.92	.97	1.00	1.03	1.07	1.11	1.20	1.30	1.46	1.63
214	105	.56	.59	.62	.64	.67	.69	.71	.74	.78	.81	.83	.85	.87	.89	.95	1.01	1.10	1.21
232	110	.50	.53	.55	.57	.58	.60	.62	.63	.66	.69	.70	.71	.73	.75	.79	.83	.87	.93

**Note:** Table 2 on page 9 presents only the standard model selections. Other models exist for special horsepower or layout applications. Please consult the factory or EVAPCO Representative for the special situations.



# ATC-E Selection Procedure

**Table 2 - Unit Heat Rejection**

ATC, ATC-X & ATC-M Models													
Model	MBH Base	Model	MBH Base	Model	MBH Base	Model	MBH Base	Model	MBH Base	Model	MBH Base	Model	MBH Base
ATC-50E	735	ATC-338E	4969	ATC-XC462E	6791	ATC-607E	8923	ATC-780E	11466	ATC-963E	14156	ATC-1425E	20950
ATC-65E	956	ATC-M344E	5057	ATC-M467E	6865	ATC-M607E	8923	ATC-781E	11477	ATC-964E	14171	ATC-1426E	20962
ATC-80E	1176	ATC-XC346E	5086	ATC-471E	6924	ATC-608E	8938	ATC-791E	11628	ATC-967E	14218	ATC-1495E	21974
ATC-90E	1323	ATC-350E	5145	ATC-472E	6938	ATC-XE608E	8938	ATC-792E	11642	ATC-979E	14395	ATC-1496E	21991
ATC-105E	1544	ATC-351E	5160	ATC-XE472E	6938	ATC-609E	8947	ATC-793E	11657	ATC-980E	14406	ATC-1561E	22954
ATC-120E	1764	ATC-M352E	5174	ATC-473E	6948	ATC-XC611E	8982	ATC-XC804E	11819	ATC-XE984E	14465	ATC-1562E	22961
ATC-135E	1985	ATC-355E	5219	ATC-474E	6973	ATC-620E	9107	ATC-805E	11831	ATC-986E	14494	ATC-1616E	23761
ATC-150E	2205	ATC-XE356E	5233	ATC-481E	7071	ATC-M625E	9188	ATC-806E	11849	ATC-1003E	14744	ATC-1625E	23881
ATC-165E	2426	ATC-358E	5269	ATC-482E	7085	ATC-630E	9260	ATC-XE812E	11936	ATC-1004E	14759	ATC-1654E	24320
ATC-170E	2499	ATC-XC360E	5292	ATC-M483E	7100	ATC-631E	9276	ATC-816E	12001	ATC-1006E	14789	ATC-1655E	24329
ATC-181E	2661	ATC-361E	5307	ATC-486E	7140	ATC-632E	9290	ATC-817E	12010	ATC-1007E	14803	ATC-1708E	25106
ATC-187E	2751	ATC-362E	5321	ATC-XE492E	7232	ATC-M634E	9320	ATC-818E	12025	ATC-XC1011E	14862	ATC-1709E	25122
ATC-193E	2837	ATC-XE368E	5410	ATC-M494E	7262	ATC-639E	9392	ATC-821E	12069	ATC-1026E	15082	ATC-1720E	25282
ATC-199E	2932	ATC-369E	5430	ATC-M500E	7350	ATC-XC641E	9423	ATC-822E	12083	ATC-XE1032E	15170	ATC-1729E	25410
ATC-M203E	2984	ATC-M371E	5454	ATC-501E	7365	ATC-642E	9437	ATC-827E	12160	ATC-1043E	15332	ATC-1783E	26214
ATC-204E	2999	ATC-374E	5498	ATC-503E	7394	ATC-647E	9504	ATC-830E	12199	ATC-1044E	15347	ATC-1784E	26225
ATC-208E	3058	ATC-379E	5570	ATC-504E	7409	ATC-651E	9570	ATC-831E	12216	ATC-1046E	15379	ATC-1795E	26394
ATC-211E	3102	ATC-M380E	5586	ATC-XC504E	7409	ATC-652E	9584	ATC-832E	12230	ATC-1047E	15391	ATC-1805E	26527
ATC-218E	3199	ATC-383E	5630	ATC-508E	7462	ATC-M663E	9746	ATC-840E	12348	ATC-XC1049E	15420	ATC-1841E	27063
ATC-220E	3234	ATC-385E	5663	ATC-XE516E	7585	ATC-XE665E	9776	ATC-842E	12374	ATC-1056E	15523	ATC-1851E	27216
ATC-221E	3242	ATC-387E	5689	ATC-521E	7659	ATC-666E	9793	ATC-843E	12392	ATC-1063E	15626	ATC-1861E	27354
ATC-225E	3308	ATC-XE387E	5689	ATC-522E	7673	ATC-XC669E	9834	ATC-844E	12407	ATC-1077E	15838	ATC-1879E	27628
ATC-M225E	3308	ATC-XC388E	5704	ATC-523E	7689	ATC-M674E	9908	ATC-854E	12553	ATC-1078E	15847	ATC-1915E	28152
ATC-227E	3337	ATC-392E	5759	ATC-XC525E	7718	ATC-675E	9925	ATC-XC855E	12569	ATC-1085E	15942	ATC-1925E	28294
ATC-M233E	3425	ATC-396E	5821	ATC-526E	7732	ATC-676E	9937	ATC-857E	12592	ATC-1095E	16097	ATC-1961E	28827
ATC-233E	3428	ATC-398E	5850	ATC-527E	7753	ATC-682E	10027	ATC-858E	12613	ATC-XC1112E	16346	ATC-2002E	29430
ATC-236E	3469	ATC-XC402E	5909	ATC-528E	7762	ATC-M685E	10070	ATC-865E	12721	ATC-1117E	16420	ATC-2040E	29988
ATC-238E	3497	ATC-XE406E	5968	ATC-XE528E	7762	ATC-687E	10097	ATC-869E	12769	ATC-1118E	16435	ATC-2082E	30604
ATC-241E	3543	ATC-407E	5983	ATC-535E	7865	ATC-698E	10261	ATC-879E	12921	ATC-1143E	16802	ATC-2114E	31076
ATC-246E	3619	ATC-408E	5998	ATC-536E	7879	ATC-699E	10275	ATC-880E	12936	ATC-XC1153E	16949	ATC-2158E	31725
ATC-247E	3633	ATC-409E	6006	ATC-539E	7919	ATC-701E	10305	ATC-XC884E	12995	ATC-XE1157E	17008	ATC-2178E	32017
ATC-251E	3690	ATC-411E	6042	ATC-M541E	7953	ATC-M701E	10305	ATC-892E	13107	ATC-1163E	17093	ATC-2223E	32676
ATC-253E	3721	ATC-415E	6101	ATC-XE542E	7967	ATC-702E	10319	ATC-894E	13142	ATC-1164E	17111	ATC-2256E	33161
ATC-258E	3795	ATC-416E	6115	ATC-545E	8009	ATC-703E	10339	ATC-895E	13160	ATC-1166E	17136	ATC-2273E	33413
ATC-261E	3837	ATC-421E	6189	ATC-XE553E	8129	ATC-706E	10380	ATC-XE896E	13171	ATC-1167E	17155	ATC-2320E	34100
ATC-264E	3881	ATC-422E	6203	ATC-556E	8169	ATC-XE709E	10422	ATC-XC897E	13186	ATC-1191E	17503	ATC-2324E	34157
ATC-268E	3940	ATC-423E	6224	ATC-557E	8188	ATC-713E	10475	ATC-899E	13215	ATC-1192E	17522	ATC-2404E	35335
ATC-269E	3957	ATC-M426E	6262	ATC-XC558E	8203	ATC-XC720E	10584	ATC-900E	13230	ATC-1203E	17684	ATC-2490E	36603
ATC-280E	4119	ATC-XC427E	6277	ATC-559E	8210	ATC-723E	10628	ATC-907E	13330	ATC-1204E	17699	ATC-2509E	36877
ATC-282E	4145	ATC-428E	6296	ATC-563E	8276	ATC-724E	10643	ATC-912E	13413	ATC-XC1210E	17787	ATC-2647E	38904
ATC-294E	4326	ATC-M439E	6453	ATC-564E	8291	ATC-725E	10660	ATC-913E	13421	ATC-XC1222E	17963	ATC-2765E	40644
ATC-296E	4351	ATC-441E	6483	ATC-578E	8503	ATC-XE742E	10907	ATC-919E	13509	ATC-1239E	18214	ATC-2855E	41964
ATC-XE298E	4381	ATC-442E	6490	ATC-XC579E	8511	ATC-746E	10973	ATC-920E	13524	ATC-1240E	18228	ATC-2900E	42630
ATC-M301E	4425	ATC-XC443E	6512	ATC-581E	8547	ATC-747E	10987	ATC-XC925E	13598	ATC-XC1264E	18581	ATC-3029E	44531
ATC-304E	4469	ATC-XE448E	6586	ATC-583E	8568	ATC-748E	10996	ATC-926E	13619	ATC-XC1282E	18845	ATC-3210E	47181
ATC-M304E	4469	ATC-450E	6615	ATC-591E	8688	ATC-749E	11010	ATC-930E	13671	ATC-1283E	18860	ATC-3232E	47518
ATC-305E	4489	ATC-453E	6659	ATC-M591E	8688	ATC-755E	11091	ATC-935E	13746	ATC-1284E	18875	ATC-3313E	48706
ATC-M314E	4616	ATC-M456E	6703	ATC-592E	8702	ATC-M755E	11099	ATC-943E	13862	ATC-1293E	19009	ATC-3336E	49032
ATC-316E	4645	ATC-456E	6706	ATC-XE596E	8761	ATC-771E	11334	ATC-944E	13877	ATC-1294E	19022	ATC-3459E	50855
ATC-325E	4777	ATC-457E	6715	ATC-598E	8789	ATC-772E	11348	ATC-XE947E	13921	ATC-XC1340E	19698	ATC-3482E	51188
ATC-326E	4792	ATC-460E	6762	ATC-601E	8842	ATC-XC775E	11393	ATC-949E	13950	ATC-1364E	20054	ATC-3591E	52783
ATC-XE333E	4895	ATC-462E	6791	ATC-M604E	8879	ATC-778E	11441	ATC-960E	14112	ATC-1365E	20066	ATC-3714E	545973

# Engineering Dimensions & Data

## Models ATC-50E to 165E

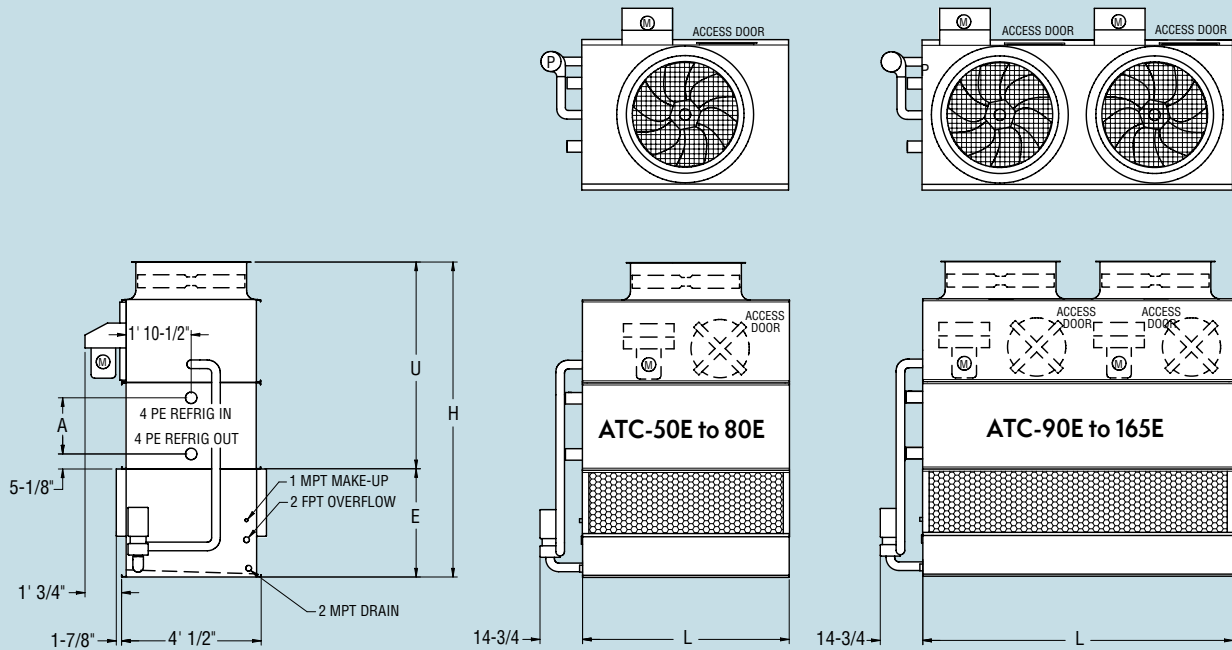

**Table 5 Engineering Data**

Model No.	R-717 Tons*	Fans		Weights†			Refrigerant Operating Charge lbs.***	Coil Volume ft <sup>3</sup>	Spray Pump		Remote Pump		Dimensions					
		HP	CFM	Shipping	Heaviest Section†	Operating			HP	GPM	Gallons Req'd**	Conn. Size	Operating Weight	Height H	Upper U	Lower E	Coil A	Length L
ATC-50E	35	3	11,800	2,780	2,270	3,960	51	7	3/4	135	120	6"	3,500	9' 1-3/8"	5' 11-3/4"	3' 1-5/8"	19-1/2"	5' 11-3/4"
ATC-65E	46	5	12,600	3,160	2,650	4,370	66	9	3/4	135	120	6"	3,910	9' 8-7/8"	6' 7-1/4"	3' 1-5/8"	27"	5' 11-3/4"
ATC-80E	57	5	12,000	3,570	3,060	4,810	81	11	3/4	135	120	6"	4,350	10' 4-3/8"	7' 2-3/4"	3' 1-5/8"	34-1/2"	5' 11-3/4"
ATC-90E	64	(2) 3	21,200	4,110	3,440	5,820	75	10	1	200	180	6"	5,200	9' 1-3/8"	5' 11-3/4"	3' 1-5/8"	19-1/2"	8' 11-3/4"
ATC-105E	74	(2) 3	19,800	4,660	3,990	6,410	97	13	1	200	180	6"	5,790	9' 8-7/8"	6' 7-1/4"	3' 1-5/8"	27"	8' 11-3/4"
ATC-120E	85	(2) 3	19,100	5,250	4,580	7,050	120	16	1	200	180	6"	6,430	10' 4-3/8"	7' 2-3/4"	3' 1-5/8"	34-1/2"	8' 11-3/4"
ATC-135E	96	(2) 3	25,300	5,690	4,870	8,000	129	18	1-1/2	270	230	8"	7,220	9' 8-7/8"	6' 7-1/4"	3' 1-5/8"	27"	11' 11-3/4"
ATC-150E	106	(2) 3	23,800	6,490	5,670	8,860	159	22	1-1/2	270	230	8"	8,080	10' 4-3/8"	7' 2-3/4"	3' 1-5/8"	34-1/2"	11' 11-3/4"
ATC-165E	117	(2) 5	25,900	6,510	5,690	8,880	159	22	1-1/2	270	230	8"	8,100	10' 4-3/8"	7' 2-3/4"	3' 1-5/8"	34-1/2"	11' 11-3/4"

\* Tons at standard conditions: 96.3°F condensing, 20°F suction and 78°F W.B.

\*\* Gallons shown is water in suspension in unit and piping. Allow for additional water in bottom of remote sump to cover pump suction and strainer during operation. (12" would normally be sufficient.)

† Heaviest section is the coil section. **When 5.12g seismic design is required consult the factory for specific weights.**

\*\*\* Refrigerant charge is shown for R-717. Multiply by 1.93 for R-22 and 1.98 for R-134a.

Units are designed to fit into standard container for ease of transportation.

Dimensions are subject to change. Do not use for pre-fabrication. Quantity of coil connections subject to change based on refrigerant and design conditions.

# Engineering Dimensions & Data

## Models ATC-181E to 411E

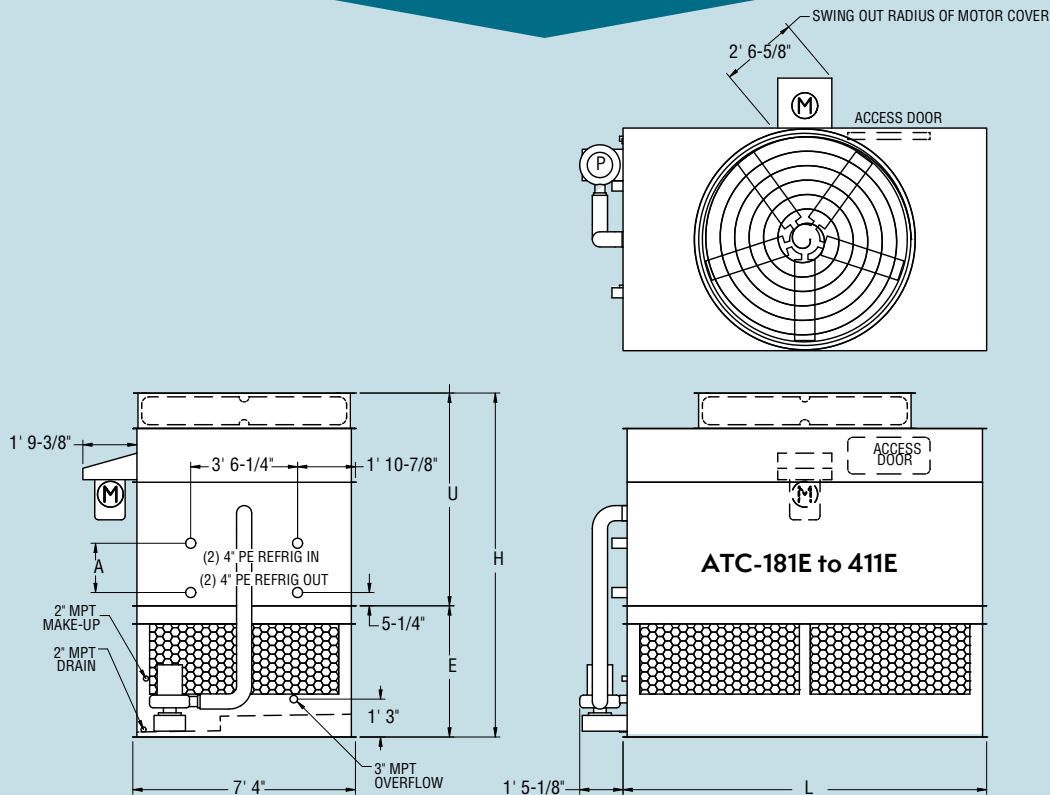

**Table 6 Engineering Data**

Model No.	R-717 Tons*	Fans		Weights†			Refrigerant Operating Charge lbs.***	Coil Volume ft <sup>3</sup>	Spray Pump		Remote Pump			Dimensions				
		HP	CFM	Shipping	Heaviest Section†	Operating			HP	GPM	Gallons Req'd**	Conn. Size	Operating Weight	Height H	Upper U	Lower E	Coil A	Length L
ATC-181E	129	7.5	34,120	7,550	5,960	9,020	141	19	2	410	120	8"	7,850	11' 4"	7' 1/8"	4' 3-7/8"	19-1/2"	8' 11-1/2"
ATC-193E	137	10	37,420	7,570	5,980	9,040	141	19	2	410	120	8"	7,870	11' 4"	7' 1/8"	4' 3-7/8"	19-1/2"	8' 11-1/2"
ATC-204E	145	7.5	32,130	9,680	8,090	11,230	227	31	2	410	120	8"	10,060	12' 7"	8' 3-1/8"	4' 3-7/8"	34-1/2"	8' 11-1/2"
ATC-208E	148	10	36,330	8,600	7,010	10,110	184	25	2	410	120	8"	8,940	11' 11/2"	7' 7-5/8"	4' 3-7/8"	27"	8' 11-1/2"
ATC-211E	150	7.5	31,140	10,740	9,150	12,340	270	37	2	410	120	8"	11,170	13' 21/2"	8' 10-5/8"	4' 3-7/8"	42"	8' 11-1/2"
ATC-220E	157	10	35,240	9,700	8,110	11,250	227	31	2	410	120	8"	10,080	12' 7"	8' 3-1/8"	4' 3-7/8"	34-1/2"	8' 11-1/2"
ATC-225E	160	15	40,700	8,720	7,130	10,230	184	25	2	410	120	8"	9,060	11' 11/2"	7' 7-5/8"	4' 3-7/8"	27"	8' 11-1/2"
ATC-227E	161	10	34,150	10,760	9,170	12,360	270	37	2	410	120	8"	11,190	13' 21/2"	8' 10-5/8"	4' 3-7/8"	42"	8' 11-1/2"
ATC-236E	168	10	33,060	11,890	10,300	13,530	313	43	2	410	120	8"	12,360	13' 81/4"	9' 4-3/8"	4' 3-7/8"	47-3/4"	8' 11-1/2"
ATC-241E	171	15	39,470	9,820	8,230	11,370	227	31	2	410	120	8"	10,200	12' 7"	8' 3-1/8"	4' 3-7/8"	34-1/2"	8' 11-1/2"
ATC-251E	179	15	38,250	10,880	9,290	12,480	270	37	2	410	120	8"	11,310	13' 21/2"	8' 10-5/8"	4' 3-7/8"	42"	8' 11-1/2"
ATC-261E	186	15	37,030	12,010	10,420	13,650	313	43	2	410	120	8"	12,480	13' 81/4"	9' 4-3/8"	4' 3-7/8"	47-3/4"	8' 11-1/2"
ATC-264E	188	15	51,680	9,270	7,370	11,370	185	25	3	550	160	10"	9,760	11' 4"	7' 1/8"	4' 3-7/8"	19-1/2"	11' 11-3/4"
ATC-282E	200	15	50,180	10,670	8,770	12,830	243	33	3	550	160	10"	11,220	11' 11-1/2"	7' 7-5/8"	4' 3-7/8"	27"	11' 11-3/4"
ATC-304E	216	15	48,670	12,050	10,150	14,270	301	41	3	550	160	10"	12,660	12' 7"	8' 3-1/8"	4' 3-7/8"	34-1/2"	11' 11-3/4"
ATC-316E	225	20	52,760	12,110	10,210	14,330	301	41	3	550	160	10"	12,720	12' 7"	8' 3-1/8"	4' 3-7/8"	34-1/2"	11' 11-3/4"
ATC-338E	240	20	51,130	13,530	11,630	15,800	358	49	3	550	160	10"	14,190	13' 2-1/2"	8' 10-5/8"	4' 3-7/8"	42"	11' 11-3/4"
ATC-351E	249	20	49,490	14,950	13,050	17,280	416	57	3	550	160	10"	15,670	13' 8-1/4"	9' 4-3/8"	4' 3-7/8"	47-3/4"	11' 11-3/4"
ATC-268E	191	15	57,760	10,570	8,380	12,960	215	29	3	600	190	10"	11,150	11' 8-1/2"	7' 1/4"	4' 8-1/4"	19-1/2"	13' 11-3/4"
ATC-296E	210	15	56,080	12,180	9,990	14,640	282	38	3	600	190	10"	12,830	12' 4"	7' 7-3/4"	4' 8-1/4"	27"	13' 11-3/4"
ATC-326E	232	15	54,400	13,840	11,650	16,360	350	48	3	600	190	10"	14,550	12' 11-1/2"	8' 3-1/4"	4' 8-1/4"	34-1/2"	13' 11-3/4"
ATC-350E	249	20	58,960	13,900	11,710	16,420	350	48	3	600	190	10"	14,610	12' 11-1/2"	8' 3-1/4"	4' 8-1/4"	34-1/2"	13' 11-3/4"
ATC-374E	266	20	57,140	15,550	13,360	18,140	417	57	3	600	190	10"	16,330	13' 7"	8' 10-3/4"	4' 8-1/4"	42"	13' 11-3/4"
ATC-396E	281	25	60,820	15,580	13,390	18,170	417	57	3	600	190	10"	16,360	13' 7"	8' 10-3/4"	4' 8-1/4"	42"	13' 11-3/4"
ATC-411E	292	25	58,880	15,610	13,420	18,270	485	66	3	600	190	10"	16,460	14' 3/4"	9' 4-1/2"	4' 8-1/4"	47-3/4"	13' 11-3/4"

\* Tons at standard conditions: 96.3°F condensing, 20°F suction and 78°F W.B.

\*\* Gallons shown is water in suspension in unit and piping. Allow for additional water in bottom of remote sump to cover pump suction and strainer during operation. (12" would normally be sufficient.)

† Heaviest section is the coil section. **When 5.12g seismic design is required consult the factory for specific weights.**

\*\*\* Refrigerant charge is shown for R-717. Multiply by 1.93 for R-22 and 1.98 for R-134a.

Units are designed to fit into standard container for ease of transportation.

Dimensions are subject to change. Do not use for pre-fabrication. Quantity of coil connections subject to change based on refrigerant and design conditions.

# Engineering Dimensions & Data

## Models ATC-362E to 522E

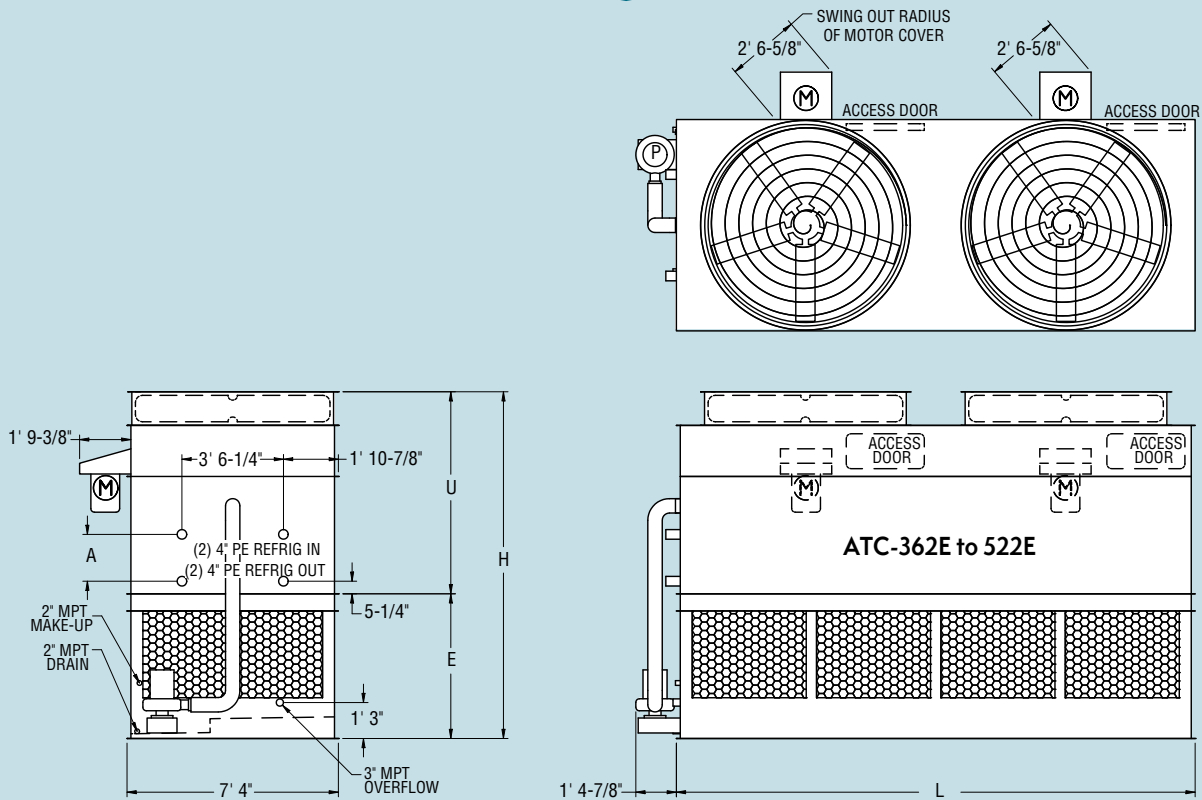

**Table 7 Engineering Data**

Model No.	R-717 Tons*	Fans		Weights†			Refrigerant Operating Charge lbs.***	Coil Volume ft <sup>3</sup>	Spray Pump		Remote Pump			Dimensions				
		HP	CFM	Shipping	Heaviest Section†	Operating			HP	GPM	Gallons Req'd**	Conn. Size	Operating Weight	Height H	Upper U	Lower E	Coil A	Length L
ATC-362E	257	(2) 7.5	68,480	13,970	10,950	17,210	274	37	5	800	240	12"	14,830	12' 3/8"	7' 1/8"	5' 1/4"	19 1/2"	18' 0"
ATC-387E	275	(2) 10	75,120	14,000	10,980	17,240	274	37	5	800	240	12"	14,860	12' 3/8"	7' 1/8"	5' 1/4"	19 1/2"	18' 0"
ATC-407E	289	(2) 7.5	64,490	18,180	15,160	21,590	448	61	5	800	240	12"	19,210	13' 3 3/8"	8' 3 1/8"	5' 1/4"	34 1/2"	18' 0"
ATC-415E	295	(2) 10	72,930	16,100	13,080	19,430	361	49	5	800	240	12"	17,050	12' 7 7/8"	7' 7 5/8"	5' 1/4"	27"	18' 0"
ATC-422E	300	(2) 7.5	62,500	20,350	17,330	23,850	535	73	5	800	240	12"	21,470	13' 10 7/8"	8' 10 5/8"	5' 1/4"	42"	18' 0"
ATC-441E	313	(2) 10	70,740	18,210	15,190	21,620	448	61	5	800	240	12"	19,240	13' 3 3/8"	8' 3 1/8"	5' 1/4"	34 1/2"	18' 0"
ATC-453E	322	(2) 15	81,700	16,350	13,330	19,680	361	49	5	800	240	12"	17,300	12' 7 7/8"	7' 7 5/8"	5' 1/4"	27"	18' 0"
ATC-462E	328	(2) 10	68,560	20,380	17,360	23,880	535	73	5	800	240	12"	21,500	13' 10 7/8"	8' 10 5/8"	5' 1/4"	42"	18' 0"
ATC-472E	335	(2) 10	66,370	22,540	19,520	26,130	622	85	5	800	240	12"	23,750	14' 4 5/8"	9' 4 3/8"	5' 1/4"	47 3/4"	18' 0"
ATC-482E	342	(2) 15	79,250	18,460	15,440	21,870	448	61	5	800	240	12"	19,490	13' 3 3/8"	8' 3 1/8"	5' 1/4"	34 1/2"	18' 0"
ATC-504E	358	(2) 15	76,800	20,630	17,610	24,130	535	73	5	800	240	12"	21,750	13' 10 7/8"	8' 10 5/8"	5' 1/4"	42"	18' 0"
ATC-522E	371	(2) 15	74,350	22,790	19,770	26,380	622	85	5	800	240	12"	24,000	14' 4 5/8"	9' 4 3/8"	5' 1/4"	47 3/4"	18' 0"

\* Tons at standard conditions: 96.3°F condensing, 20°F suction and 78°F W.B.

\*\* Gallons shown is water in suspension in unit and piping. Allow for additional water in bottom of remote sump to cover pump suction and strainer during operation. (12" would normally be sufficient.)

† Heaviest section is the coil section. **When 5.12g seismic design is required consult the factory for specific weights.**

\*\*\* Refrigerant charge is shown for R-717. Multiply by 1.93 for R-22 and 1.98 for R-134a.

Units are designed to fit into standard container for ease of transportation.

Dimensions are subject to change. Do not use for pre-fabrication. Quantity of coil connections subject to change based on refrigerant and design conditions.

# Engineering Dimensions & Data

## Models ATC-528E to 822E

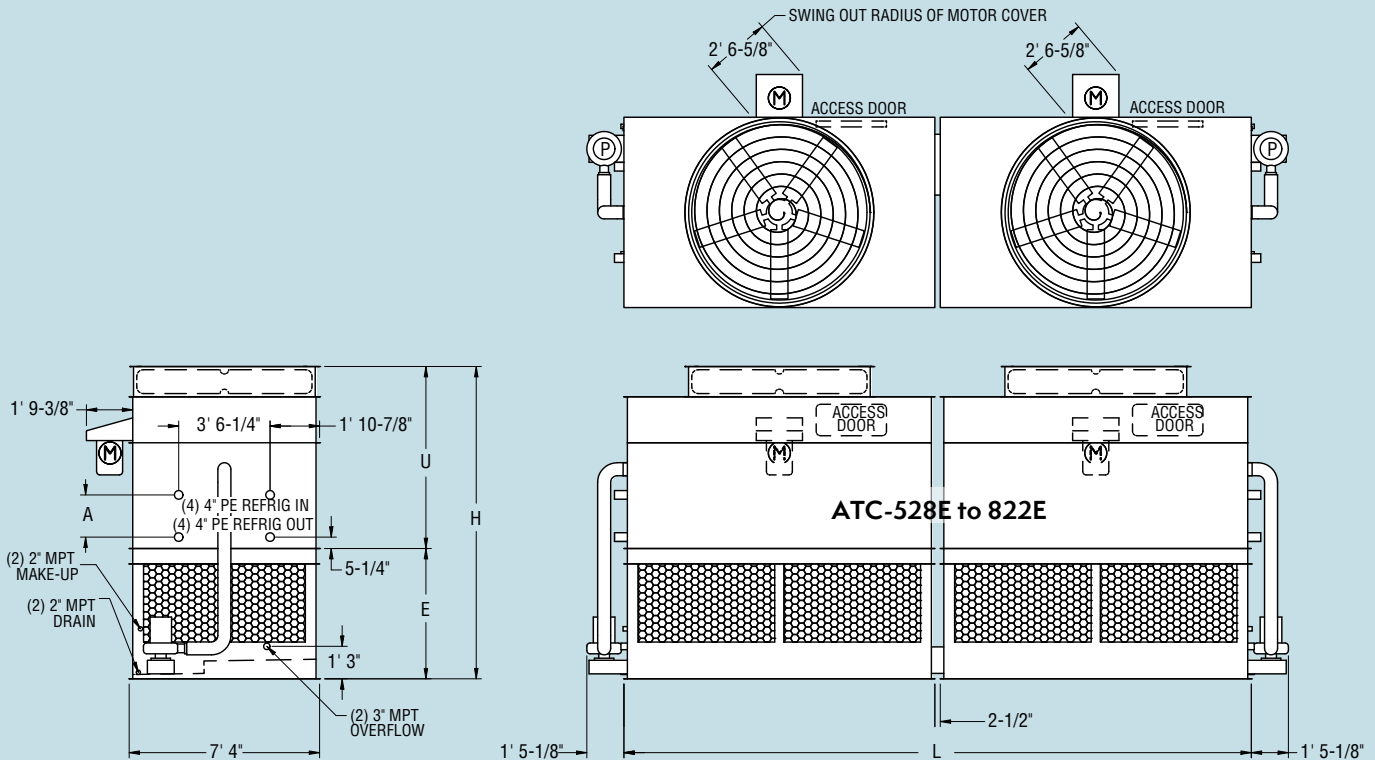

**Table 8 Engineering Data**

Model No.	R-717 Tons*	Fans		Weights†			Refrigerant Operating Charge lbs.***	Coil Volume ft <sup>3</sup>	Spray Pump		Remote Pump			Dimensions				
		HP	CFM	Shipping	Heaviest Section†	Operating			HP	GPM	Gallons Req'd**	Conn. Size	Operating Weight	Height H	Upper U	Lower E	Coil A	Length L
ATC-528E	375	(2)15	103,370	27,140	9,940	29,760	371	51	(2)3	1100	310	10"	26,460	12' 3/8"	7' 1/8"	5' 1/4"	19 1/2"	24' 2"
ATC-564E	400	(2)15	100,360	30,100	11,420	32,840	486	66	(2)3	1100	310	10"	29,540	12' 7 7/8"	7' 5/8"	5' 1/4"	27"	24' 2"
ATC-608E	432	(2)15	97,350	33,060	12,900	35,920	602	82	(2)3	1100	310	10"	32,620	13' 3 3/8"	8' 31/8"	5' 1/4"	34 1/2"	24' 2"
ATC-632E	449	(2)20	105,510	33,180	12,960	36,040	602	82	(2)3	1100	310	10"	32,740	13' 3 3/8"	8' 31/8"	5' 1/4"	34 1/2"	24' 2"
ATC-676E	480	(2)20	102,250	36,220	14,480	39,180	717	98	(2)3	1100	310	10"	35,880	13' 10 7/8"	8' 10 5/8"	5' 1/4"	42"	24' 2"
ATC-702E	498	(2)20	98,990	39,300	16,020	42,380	832	113	(2)3	1100	310	10"	39,080	14' 4 5/8"	9' 4 3/8"	5' 1/4"	47 3/4"	24' 2"
ATC-536E	381	(2)15	115,530	21,140	8,380	25,920	430	59	(2)3	1200	190	10"	22,300	12' 6 1/2"	7' 1/4"	5' 6 1/4"	19 1/2"	28' 2"
ATC-592E	420	(2)15	112,160	24,360	9,990	29,280	565	77	(2)3	1200	190	10"	25,660	13' 2"	7' 7 3/4"	5' 6 1/4"	27"	28' 2"
ATC-652E	463	(2)15	108,800	27,680	11,650	32,720	700	95	(2)3	1200	190	10"	29,100	13' 9 1/2"	8' 3 1/4"	5' 6 1/4"	34 1/2"	28' 2"
ATC-699E	496	(2)20	117,930	27,800	11,710	32,840	700	95	(2)3	1200	190	10"	29,220	13' 9 1/2"	8' 3 1/4"	5' 6 1/4"	34 1/2"	28' 2"
ATC-749E	532	(2)20	114,280	31,100	13,360	36,280	835	114	(2)3	1200	190	10"	32,660	14' 5"	8' 10 3/4"	5' 6 1/4"	42"	28' 2"
ATC-793E	563	(2)25	121,650	31,160	13,390	36,340	835	114	(2)3	1200	190	10"	32,720	14' 5"	8' 10 3/4"	5' 6 1/4"	42"	28' 2"
ATC-822E	583	(2)25	117,760	31,220	13,420	36,540	970	132	(2)3	1200	190	10"	32,920	14' 10 3/4"	9' 4 1/2"	5' 6 1/4"	47 3/4"	28' 2"

\* Tons at standard conditions: 96.3°F condensing, 20°F suction and 78°F W.B.

\*\* Gallons shown is water in suspension in unit and piping. Allow for additional water in bottom of remote sump to cover pump suction and strainer during operation. (12" would normally be sufficient.)

† Heaviest section is the coil section. **When 5.12g seismic design is required consult the factory for specific weights.**

\*\*\* Refrigerant charge is shown for R-717. Multiply by 1.93 for R-22 and 1.98 for R-134a.

Units are designed to fit into standard container for ease of transportation.

Dimensions are subject to change. Do not use for pre-fabrication. Quantity of coil connections subject to change based on refrigerant and design conditions.

# Engineering Dimensions & Data

## Models ATC-724E to 1044E

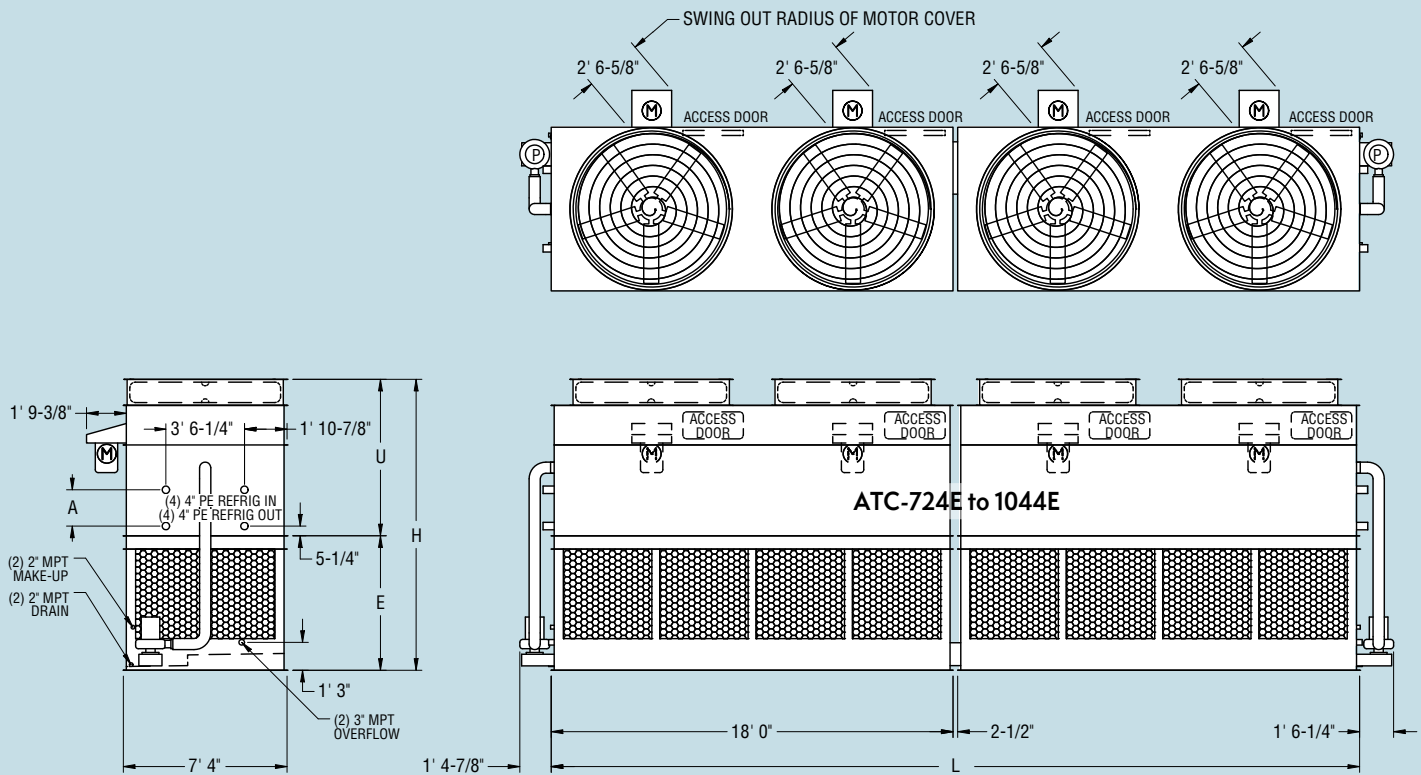

**Table 9 Engineering Data**

Model No.	R-717 Tons*	Fans		Weights†			Refrigerant Operating Charge lbs.**	Coil Volume ft <sup>3</sup>	Spray Pump		Remote Pump		Dimensions					
		HP	CFM	Shipping	Heaviest Section†	Operating			HP	GPM	Gallons Req'd**	Conn. Size	Operating Weight	Height H	Upper U	Lower E	Coil A	Length L
ATC-724E	514	(4) 7.5	136,960	41,440	14,920	45,680	548	75	(2) 5	1600	480	12"	40,840	13' 3/8"	7' 1/8"	6' 1/4"	19-1/2"	36' 2-1/2"
ATC-772E	548	(4) 10	150,240	41,500	14,950	45,740	548	75	(2) 5	1600	480	12"	40,900	13' 3/8"	7' 1/8"	6' 1/4"	19-1/2"	36' 2-1/2"
ATC-818E	581	(4) 7.5	128,980	50,480	19,440	55,060	896	122	(2) 5	1600	480	12"	50,220	14' 3-3/8"	8' 3-1/8"	6' 1/4"	34-1/2"	36' 2-1/2"
ATC-832E	591	(4) 10	145,860	45,900	17,150	50,320	722	98	(2) 5	1600	480	12"	45,480	13' 7-7/8"	7' 7-5/8"	6' 1/4"	27"	36' 2-1/2"
ATC-844E	599	(4) 7.5	124,990	55,120	21,760	59,880	1070	146	(2) 5	1600	480	12"	55,040	14' 10-7/8"	8' 10-5/8"	6' 1/4"	42"	36' 2-1/2"
ATC-880E	625	(4) 10	141,490	50,540	19,470	55,120	896	122	(2) 5	1600	480	12"	50,280	14' 3-3/8"	8' 3-1/8"	6' 1/4"	34-1/2"	36' 2-1/2"
ATC-900E	639	(4) 15	163,400	46,400	17,400	50,820	722	98	(2) 5	1600	480	12"	45,980	13' 7-7/8"	7' 7-5/8"	6' 1/4"	27"	36' 2-1/2"
ATC-920E	653	(4) 10	137,110	55,180	21,790	59,940	1070	146	(2) 5	1600	480	12"	55,100	14' 10-7/8"	8' 10-5/8"	6' 1/4"	42"	36' 2-1/2"
ATC-944E	670	(4) 10	132,740	59,940	24,170	64,880	1245	170	(2) 5	1600	480	12"	60,040	15' 4-5/8"	9' 4-3/8"	6' 1/4"	47-3/4"	36' 2-1/2"
ATC-964E	684	(4) 15	158,500	51,040	19,720	55,620	896	122	(2) 5	1600	480	12"	50,780	14' 3-3/8"	8' 3-1/8"	6' 1/4"	34-1/2"	36' 2-1/2"
ATC-1004E	713	(4) 15	153,600	55,680	22,040	60,440	1070	146	(2) 5	1600	480	12"	55,600	14' 10-7/8"	8' 10-5/8"	6' 1/4"	42"	36' 2-1/2"
ATC-1044E	741	(4) 15	148,700	60,440	24,420	65,380	1245	170	(2) 5	1600	480	12"	60,540	15' 4-5/8"	9' 4-3/8"	6' 1/4"	47-3/4"	36' 2-1/2"

\* Tons at standard conditions: 96.3°F condensing, 20°F suction and 78°F W.B.

\*\* Gallons shown is water in suspension in unit and piping. Allow for additional water in bottom of remote sump to cover pump suction and strainer during operation. (12" would normally be sufficient.)

† Heaviest section is the coil section. **When 5.12g seismic design is required consult the factory for specific weights.**

\*\*\* Refrigerant charge is shown for R-717. Multiply by 1.93 for R-22 and 1.98 for R-134a.

Units are designed to fit into standard container for ease of transportation.

Dimensions are subject to change. Do not use for pre-fabrication. Quantity of coil connections subject to change based on refrigerant and design conditions.

# Engineering Dimensions & Data

## Models ATC-361E to 821E

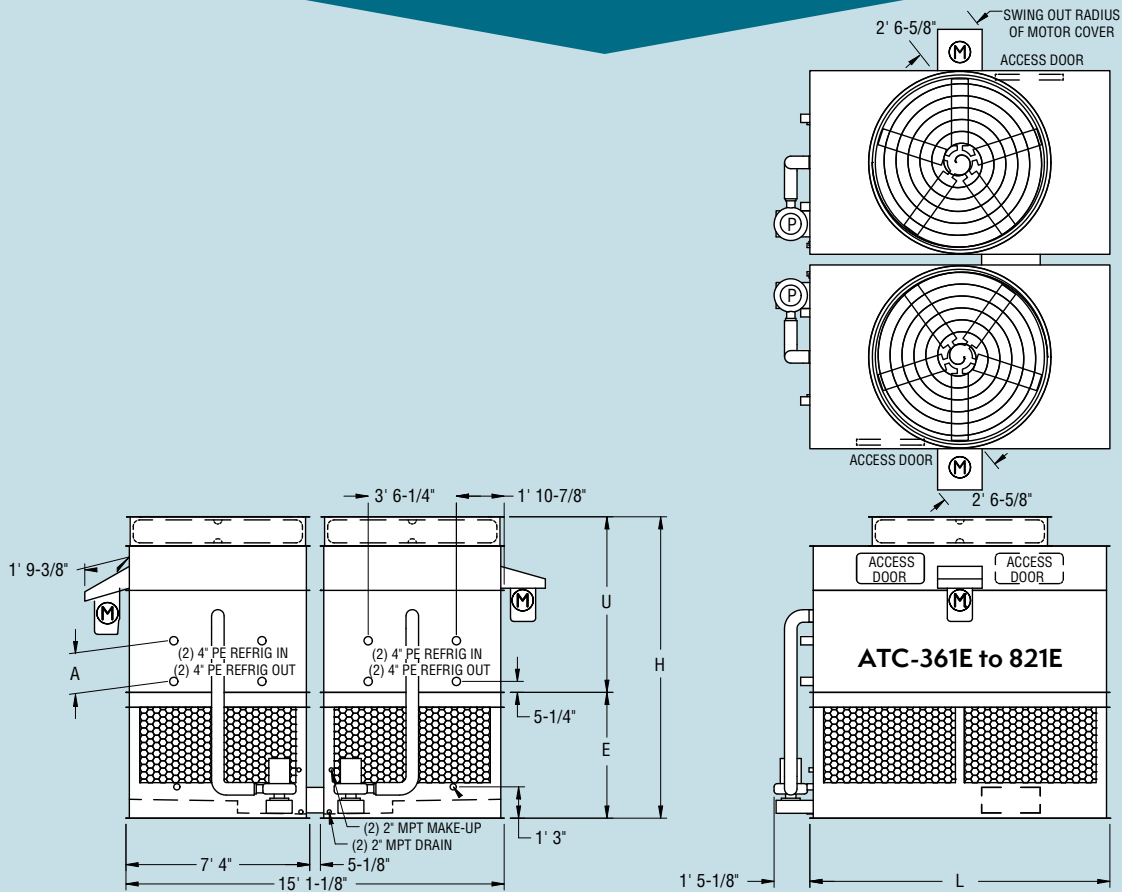

**Table 10 Engineering Data**

Model No.	R-717 Tons <sup>a</sup>	Fans		Weights <sup>†</sup>			Refrigerant Operating Charge lbs. <sup>***</sup>	Coil Volume ft <sup>3</sup>	Spray Pump		Remote Pump		Dimensions					
		HP	CFM	Shipping	Heaviest Section <sup>†</sup>	Operating			HP	GPM	Gallons Req'd <sup>**</sup>	Conn. Size	Operating Weight	Height H	Upper U	Lower E	Coil A	Length L
ATC-361E	257	2 7.5	68,240	22,460	8,180	24,040	282	38	2 2	820	240	8"	21,620	12' 3/8"	7' 1/8"	5' 1/4"	19-1/2"	8' 11-1/2"
ATC-383E	272	2 10	74,830	22,500	8,200	24,080	282	38	2 2	820	240	8"	21,660	12' 3/8"	7' 1/8"	5' 1/4"	19-1/2"	8' 11-1/2"
ATC-408E	290	2 7.5	64,270	26,980	10,440	28,720	454	62	2 2	820	240	8"	26,300	13' 3/8"	8' 3-1/8"	5' 1/4"	34-1/2"	8' 11-1/2"
ATC-416E	296	2 10	72,660	24,660	9,280	26,320	368	50	2 2	820	240	8"	23,900	12' 7/8"	7' 7-5/8"	5' 1/4"	27"	8' 11-1/2"
ATC-421E	299	2 7.5	62,280	29,300	11,600	31,140	540	74	2 2	820	240	8"	28,720	13' 10' 7/8"	8' 10-5/8"	5' 1/4"	42"	8' 11-1/2"
ATC-439E	312	2 10	70,480	27,020	10,460	28,760	454	62	2 2	820	240	8"	26,340	13' 3/8"	8' 3-1/8"	5' 1/4"	34-1/2"	8' 11-1/2"
ATC-450E	320	2 15	81,390	24,900	9,400	26,560	368	50	2 2	820	240	8"	24,140	12' 7/8"	7' 7-5/8"	5' 1/4"	27"	8' 11-1/2"
ATC-460E	327	2 10	68,300	29,340	11,620	31,180	540	74	2 2	820	240	8"	28,760	13' 10' 7/8"	8' 10-5/8"	5' 1/4"	42"	8' 11-1/2"
ATC-471E	335	2 10	66,120	31,860	12,880	33,780	626	85	2 2	820	240	8"	31,360	14' 4' 5/8"	9' 4-3/8"	5' 1/4"	47-3/4"	8' 11-1/2"
ATC-481E	342	2 15	78,950	27,260	10,580	29,000	454	62	2 2	820	240	8"	26,580	13' 3/8"	8' 3-1/8"	5' 1/4"	34-1/2"	8' 11-1/2"
ATC-501E	356	2 15	76,510	29,580	11,740	31,420	540	74	2 2	820	240	8"	29,000	13' 10' 7/8"	8' 10-5/8"	5' 1/4"	42"	8' 11-1/2"
ATC-521E	370	2 15	74,070	32,100	13,000	34,020	626	85	2 2	820	240	8"	31,600	14' 4' 5/8"	9' 4-3/8"	5' 1/4"	47-3/4"	8' 11-1/2"
ATC-526E	374	2 15	103,370	27,140	9,940	29,760	371	51	2 3	1100	310	10"	26,460	12' 3/8"	7' 1/8"	5' 1/4"	19-1/2"	11' 11-3/4"
ATC-563E	400	2 15	100,360	30,100	11,420	32,840	486	66	2 3	1100	310	10"	29,540	12' 7/8"	7' 7-5/8"	5' 1/4"	27"	11' 11-3/4"
ATC-607E	431	2 15	97,350	33,060	12,900	35,920	602	82	2 3	1100	310	10"	32,620	13' 3/8"	8' 3-1/8"	5' 1/4"	34-1/2"	11' 11-3/4"
ATC-631E	448	2 20	105,510	33,180	12,960	36,040	602	82	2 3	1100	310	10"	32,740	13' 3/8"	8' 3-1/8"	5' 1/4"	34-1/2"	11' 11-3/4"
ATC-674E	479	2 20	102,250	36,220	14,480	39,180	717	98	2 3	1100	310	10"	35,880	13' 10' 7/8"	8' 10-5/8"	5' 1/4"	42"	11' 11-3/4"
ATC-701E	498	2 20	98,990	39,300	16,020	42,380	832	113	2 3	1100	310	10"	39,080	14' 4' 5/8"	9' 4-3/8"	5' 1/4"	47-3/4"	11' 11-3/4"
ATC-535E	380	2 15	115,530	21,140	8,380	25,920	430	59	2 3	1200	190	10"	22,300	12' 6-1/2"	7' 1/4"	5' 6-1/4"	19-1/2"	13' 11-3/4"
ATC-591E	420	2 15	112,160	24,360	9,990	29,280	565	77	2 3	1200	190	10"	25,660	13' 2"	7' 7-3/4"	5' 6-1/4"	27"	13' 11-3/4"
ATC-651E	462	2 15	108,800	27,680	11,650	32,720	700	95	2 3	1200	190	10"	29,100	13' 9-1/2"	8' 3-1/4"	5' 6-1/4"	34-1/2"	13' 11-3/4"
ATC-698E	496	2 20	117,930	27,800	11,710	32,840	700	95	2 3	1200	190	10"	29,220	13' 9-1/2"	8' 3-1/4"	5' 6-1/4"	34-1/2"	13' 11-3/4"
ATC-748E	531	2 20	114,280	31,100	13,360	36,280	835	114	2 3	1200	190	10"	32,660	14' 5"	8' 10-3/4"	5' 6-1/4"	42"	13' 11-3/4"
ATC-792E	562	2 25	121,650	31,160	13,390	36,340	835	114	2 3	1200	190	10"	32,720	14' 5"	8' 10-3/4"	5' 6-1/4"	42"	13' 11-3/4"
ATC-821E	583	2 25	117,760	31,220	13,420	36,540	970	132	2 3	1200	190	10"	32,920	14' 10-3/4"	9' 4-1/2"	5' 6-1/4"	47-3/4"	13' 11-3/4"

<sup>a</sup> Tons at standard conditions: 96.3°F condensing, 20°F suction and 78°F W.B.

<sup>\*\*</sup> Gallons shown is water in suspension in unit and piping. Allow for additional water in bottom of remote sump to cover pump suction and strainer during operation. (12" would normally be sufficient.)

<sup>†</sup> Heaviest section is the coil section. **When 5.12g seismic design is required consult the factory for specific weights.**

<sup>\*\*\*</sup> Refrigerant charge is shown for R-717. Multiply by 1.93 for R-22 and 1.98 for R-134a.

Units are designed to fit into standard container for ease of transportation.

Dimensions are subject to change. Do not use for pre-fabrication. Quantity of coil connections subject to change based on refrigerant and design conditions.

# Engineering Dimensions & Data

## Models ATC-723E to 1043E

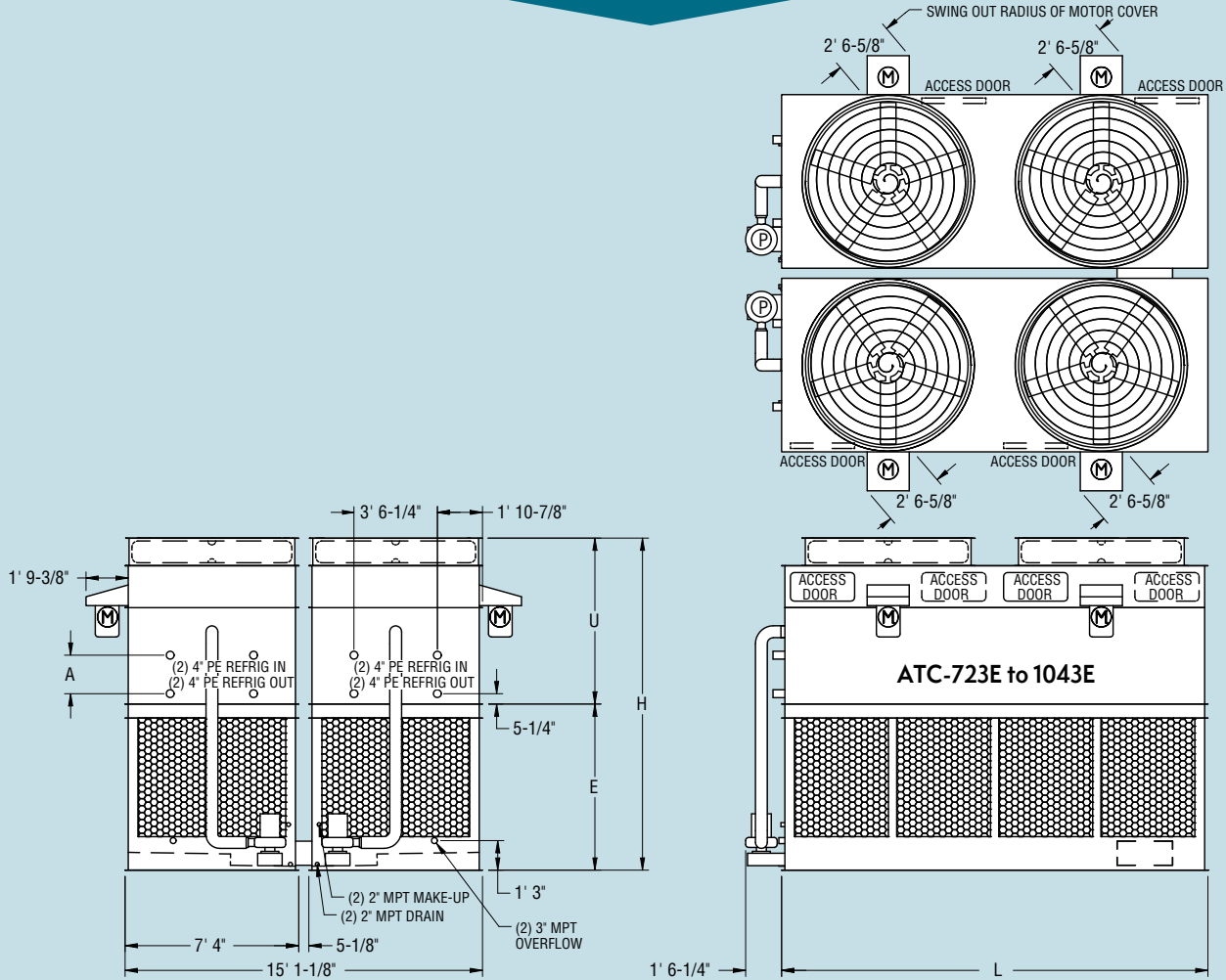

**Table 11 Engineering Data**

Model No.	R-717 Tons <sup>*</sup>	Fans		Weights <sup>†</sup>			Refrigerant Operating Charge lbs. <sup>***</sup>	Coil Volume ft <sup>3</sup>	Spray Pump		Remote Pump			Dimensions				
		HP	CFM	Shipping	Heaviest Section <sup>†</sup>	Operating			HP	GPM	Gallons Req'd <sup>**</sup>	Conn. Size	Operating Weight	Height H	Upper U	Lower E	Coil A	Length L
ATC-723E	513	(4) 7.5	136,960	41,440	14,920	45,680	548	75	(2) 5	1600	480	12"	40,840	14' 3/8"	7' 1/8"	7' 1/4"	19 1/2"	18' 0"
ATC-771E	547	(4) 10	150,240	41,500	14,950	45,740	548	75	(2) 5	1600	480	12"	40,900	14' 3/8"	7' 1/8"	7' 1/4"	19 1/2"	18' 0"
ATC-817E	580	(4) 7.5	128,980	50,480	19,440	55,060	896	122	(2) 5	1600	480	12"	50,220	15' 3 3/8"	8' 3 1/8"	7' 1/4"	34 1/2"	18' 0"
ATC-831E	590	(4) 10	145,860	45,900	17,150	50,320	722	98	(2) 5	1600	480	12"	45,480	14' 7 7/8"	7' 7 5/8"	7' 1/4"	27"	18' 0"
ATC-843E	598	(4) 7.5	124,990	55,120	21,760	59,880	1070	146	(2) 5	1600	480	12"	55,040	15' 10 7/8"	8' 10 5/8"	7' 1/4"	42"	18' 0"
ATC-879E	624	(4) 10	141,490	50,540	19,470	55,120	896	122	(2) 5	1600	480	12"	50,280	15' 3 3/8"	8' 3 1/8"	7' 1/4"	34 1/2"	18' 0"
ATC-899E	638	(4) 15	163,400	46,400	17,400	50,820	722	98	(2) 5	1600	480	12"	45,980	14' 7 7/8"	7' 7 5/8"	7' 1/4"	27"	18' 0"
ATC-919E	652	(4) 10	137,110	55,180	21,790	59,940	1070	146	(2) 5	1600	480	12"	55,100	15' 10 7/8"	8' 10 5/8"	7' 1/4"	42"	18' 0"
ATC-943E	669	(4) 10	132,740	59,940	24,170	64,880	1245	170	(2) 5	1600	480	12"	60,040	16' 4 5/8"	9' 4 3/8"	7' 1/4"	47 3/4"	18' 0"
ATC-963E	683	(4) 15	158,500	51,040	19,720	55,620	896	122	(2) 5	1600	480	12"	50,780	15' 3 3/8"	8' 3 1/8"	7' 1/4"	34 1/2"	18' 0"
ATC-1003E	712	(4) 15	153,600	55,680	22,040	60,440	1070	146	(2) 5	1600	480	12"	55,600	15' 10 7/8"	8' 10 5/8"	7' 1/4"	42"	18' 0"
ATC-1043E	740	(4) 15	148,700	60,440	24,420	65,380	1245	170	(2) 5	1600	480	12"	60,540	16' 4 5/8"	9' 4 3/8"	7' 1/4"	47 3/4"	18' 0"

\* Tons at standard conditions: 96.3°F condensing, 20°F suction and 78°F W.B.

\*\* Gallons shown is water in suspension in unit and piping. Allow for additional water in bottom of remote sump to cover pump suction and strainer during operation. (12" would normally be sufficient.)

† Heaviest section is the coil section. **When 5.12g seismic design is required consult the factory for specific weights.**

\*\*\* Refrigerant charge is shown for R-717. Multiply by 1.93 for R-22 and 1.98 for R-134a.

Units are designed to fit into standard container for ease of transportation.

Dimensions are subject to change. Do not use for pre-fabrication. Quantity of coil connections subject to change based on refrigerant and design conditions.



# Engineering Dimensions & Data

## Models ATC-M203E to M380E

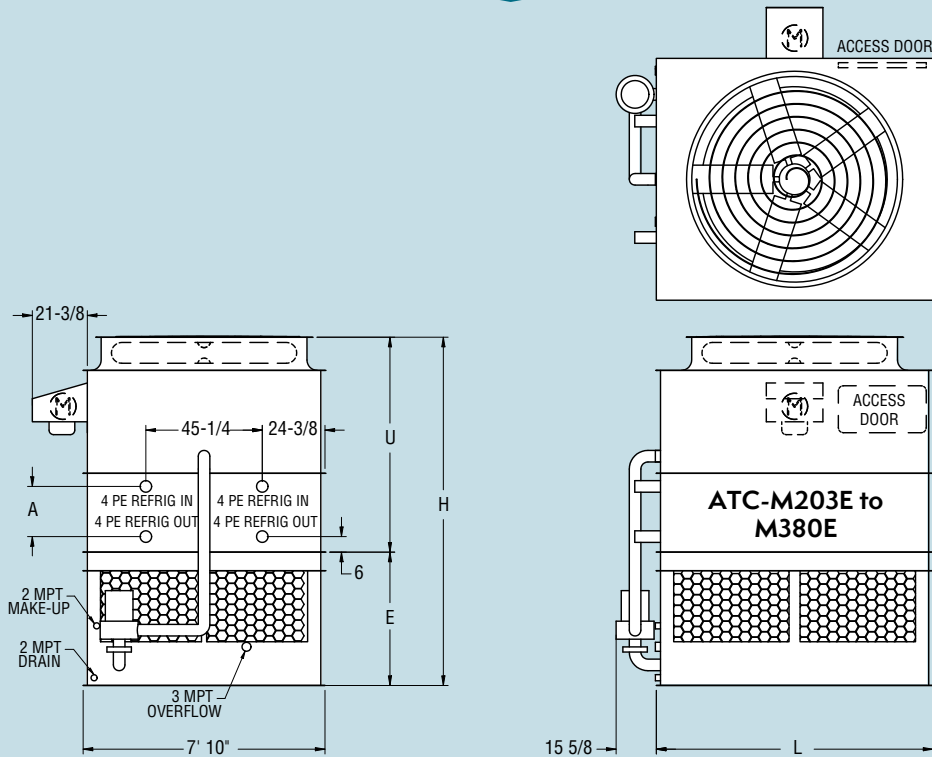

**Table 12 Engineering Data**

Model No.	R-717 Tons*	Fans		Weights†			Refrigerant Operating Charge lbs.***	Coil Volume ft <sup>3</sup>	Spray Pump		Remote Pump			Dimensions				
		HP	CFM	Shipping	Heaviest Section†	Operating			HP	GPM	Gallons Req'd**	Conn. Size	Operating Weight	Height H	Upper U	Lower E	Coil A	Length L
ATC-M203E	144	7.5	34,670	8,770	7,370	11,410	200	27	2	410	240	8"	10,180	11'10-7/8"	7'7"	4'3-7/8"	27"	8'11-1/2"
ATC-M225E	160	7.5	33,630	9,930	8,530	12,610	240	33	2	410	240	8"	11,380	12'6-3/8"	8'2-1/2"	4'3-7/8"	34-1/2"	8'11-1/2"
ATC-M233E	166	7.5	32,590	11,090	9,690	13,820	290	39	2	410	240	8"	12,590	13'1-7/8"	8'10"	4'3-7/8"	42"	8'11-1/2"
ATC-M301E	214	15	52,710	11,150	9,380	14,800	260	35	3	550	320	10"	13,170	11'10-7/8"	7'7"	4'3-7/8"	27"	11'11-3/4"
ATC-M304E	216	10	44,940	12,500	10,730	16,210	320	44	3	550	320	10"	14,580	12'6-3/8"	8'2-1/2"	4'3-7/8"	34-1/2"	11'11-3/4"
ATC-M314E	223	10	43,550	14,050	12,280	17,820	380	52	3	550	320	10"	16,190	13'1-7/8"	8'10"	4'3-7/8"	42"	11'11-3/4"
ATC-M344E	244	15	49,550	14,170	12,400	17,940	380	52	3	550	320	10"	16,310	13'1-7/8"	8'10"	4'3-7/8"	42"	11'11-3/4"
ATC-M352E	250	20	55,420	12,680	10,910	16,390	320	44	3	550	320	10"	14,760	12'6-3/8"	8'2-1/2"	4'3-7/8"	34-1/2"	11'11-3/4"
ATC-M380E	270	25	57,170	14,260	12,490	18,030	380	52	3	550	320	10"	16,400	13'1-7/8"	8'10"	4'3-7/8"	42"	11'11-3/4"

\* Tons at standard conditions: 96.3°F condensing, 20°F suction and 78°F W.B.

\*\* Gallons shown is water in suspension in unit and piping. Allow for additional water in bottom of remote sump to cover pump suction and strainer during operation. (12" would normally be sufficient.)

† Heaviest section is the coil section. **When 5.12g seismic design is required consult the factory for specific weights.**

\*\*\* Refrigerant charge is shown for R-717. Multiply by 1.93 for R-22 and 1.98 for R-134a.

Dimensions are subject to change. Do not use for pre-fabrication. Quantity of coil connections subject to change based on refrigerant and design conditions.

# Engineering Dimensions & Data

## Models ATC-M426E to M591E

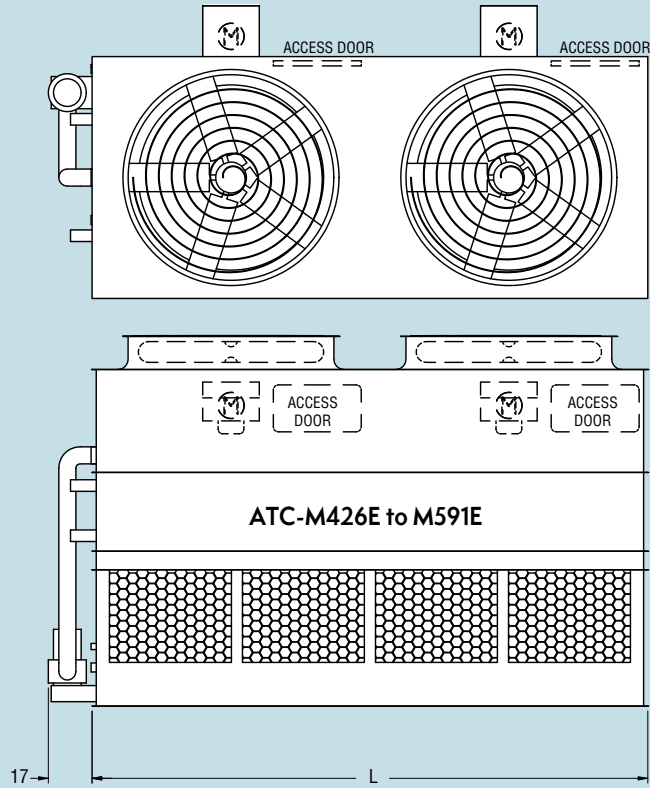
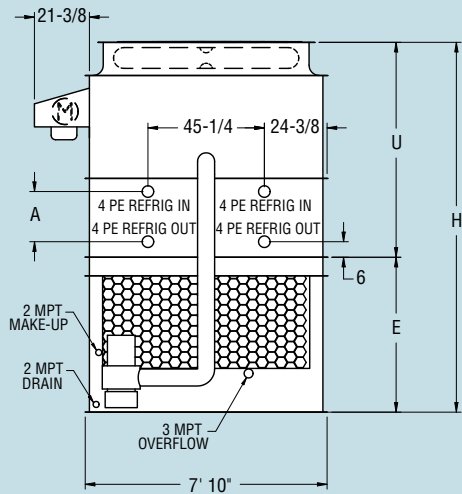

**Table 13 Engineering Data**

Model No.	R-717 Tons*	Fans		Weights†			Refrigerant Operating Charge lbs.***	Coil Volume ft <sup>3</sup>	Spray Pump		Remote Pump			Dimensions				
		HP	CFM	Shipping	Heaviest Section†	Operating			HP	GPM	Gallons Req'd**	Conn. Size	Operating Weight	Height H	Upper U	Lower E	Coil A	Length L
ATC-M426E	303	(2) 7.5	69,350	16,800	14,070	22,330	390	52	5	800	480	12"	19,900	12' 7-1/4"	7' 7"	5' 1/4"	27"	18' 0"
ATC-M456E	324	(2) 10	76,330	16,830	14,100	22,360	390	52	5	800	480	12"	19,930	12' 7-1/4"	7' 7"	5' 1/4"	27"	18' 0"
ATC-M467E	332	(2) 7.5	67,270	18,970	16,240	24,590	480	65	5	800	480	12"	22,160	13' 2-3/4"	8' 2-1/2"	5' 1/4"	34-1/2"	18' 0"
ATC-M483E	343	(2) 7.5	65,190	21,300	18,570	27,010	570	78	5	800	480	12"	24,580	13' 10-1/4"	8' 10"	5' 1/4"	42"	18' 0"
ATC-M494E	351	(2) 15	85,500	17,080	14,350	22,610	390	52	5	800	480	12"	20,180	12' 7-1/4"	7' 7"	5' 1/4"	27"	18' 0"
ATC-M500E	355	(2) 10	74,040	19,000	16,270	24,620	480	65	5	800	480	12"	22,190	13' 2-3/4"	8' 2-1/2"	5' 1/4"	34-1/2"	18' 0"
ATC-M541E	384	(2) 15	82,940	19,250	16,520	24,870	480	65	5	800	480	12"	22,440	13' 2-3/4"	8' 2-1/2"	5' 1/4"	34-1/2"	18' 0"
ATC-M591E	420	(2) 20	87,120	21,700	18,970	27,410	570	78	5	800	480	12"	24,980	13' 10-1/4"	8' 10"	5' 1/4"	42"	18' 0"

\* Tons at standard conditions: 96.3°F condensing, 20°F suction and 78°F W.B.

\*\* Gallons shown is water in suspension in unit and piping. Allow for additional water in bottom of remote sump to cover pump suction and strainer during operation. (12" would normally be sufficient.)

† Heaviest section is the coil section. **When 5.12g seismic design is required consult the factory for specific weights.**

\*\*\* Refrigerant charge is shown for R-717. Multiply by 1.93 for R-22 and 1.98 for R-134a.

Dimensions are subject to change. Do not use for pre-fabrication. Quantity of coil connections subject to change based on refrigerant and design conditions.

# Engineering Dimensions & Data

## Models ATC-M604E to M755E

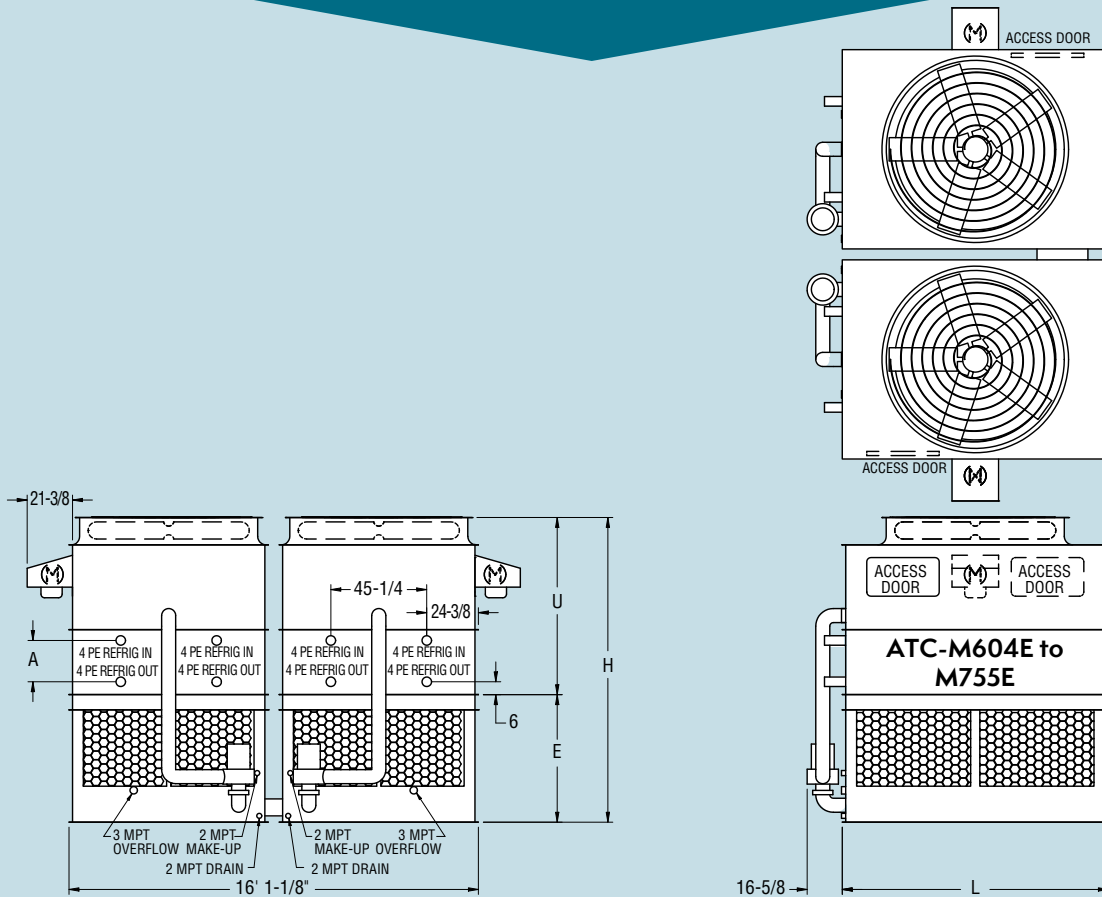

**Table 14 Engineering Data**

Model No.	R-717 Tons*	Fans		Weights†		Refrigerant Operating Charge lbs.***	Coil Volume ft <sup>3</sup>	Spray Pump		Remote Pump			Dimensions					
		HP	CFM	Shipping	Heaviest Section†			Operating	HP	GPM	Gallons Req'd**	Conn. Size	Operating Weight	Height H	Upper U	Lower E	Coil A	Length L
ATC-M604E	429	(2)10	89,880	25,000	10,730	32,420	640	87	(2)3	1100	640	10"	29,160	13' 2-3/4"	8' 2-1/2"	5' 1/4"	34-1/2"	11' 11-3/4"
ATC-M625E	444	(2)10	87,100	28,100	12,280	35,640	760	104	(2)3	1100	640	10"	32,380	13' 10-1/4"	8' 10"	5' 1/4"	42"	11' 11-3/4"
ATC-M634E	450	(2)20	114,260	22,420	9,440	29,720	520	70	(2)3	1100	640	10"	26,460	12' 7-1/4"	7' 7"	5' 1/4"	27"	11' 11-3/4"
ATC-M663E	471	(2)15	102,260	25,240	10,850	32,660	640	87	(2)3	1100	640	10"	29,400	13' 2-3/4"	8' 2-1/2"	5' 1/4"	34-1/2"	11' 11-3/4"
ATC-M685E	486	(2)15	99,100	28,340	12,400	35,880	760	104	(2)3	1100	640	10"	32,620	13' 10-1/4"	8' 10"	5' 1/4"	42"	11' 11-3/4"
ATC-M701E	498	(2)20	110,840	25,360	10,910	32,780	640	87	(2)3	1100	640	10"	29,520	13' 2-3/4"	8' 2-1/2"	5' 1/4"	34-1/2"	11' 11-3/4"
ATC-M755E	536	(2)25	114,330	28,520	12,490	36,060	760	104	(2)3	1100	640	10"	32,800	13' 10-1/4"	8' 10"	5' 1/4"	42"	11' 11-3/4"

\* Tons at standard conditions: 96.3°F condensing, 20°F suction and 78°F W.B.

\*\* Gallons shown is water in suspension in unit and piping. Allow for additional water in bottom of remote sump to cover pump suction and strainer during operation. (12" would normally be sufficient.)

† Heaviest section is the coil section. **When 5.12g seismic design is required consult the factory for specific weights.**

\*\*\* Refrigerant charge is shown for R-717. Multiply by 1.93 for R-22 and 1.98 for R-134a.

Dimensions are subject to change. Do not use for pre-fabrication. Quantity of coil connections subject to change based on refrigerant and design conditions.

# Engineering Dimensions & Data

## Models ATC-170E to 247E

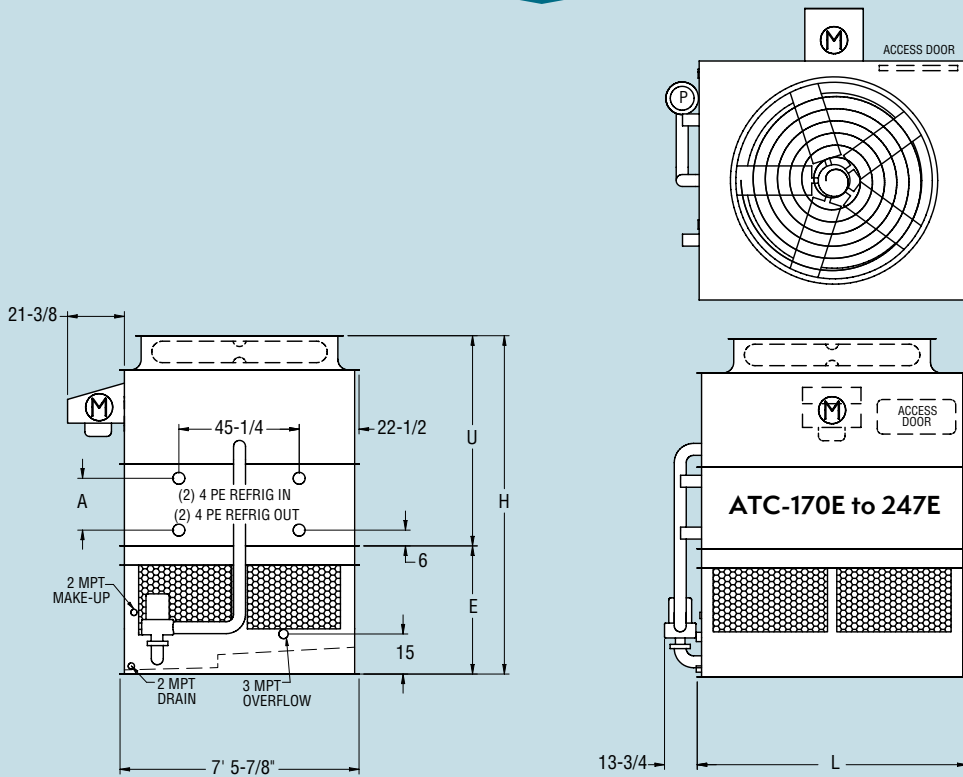

**Table 15 Engineering Data**

Model No.	R-717 Tons <sup>*</sup>	Fans		Weights <sup>†</sup>			Refrigerant Operating Charge lbs. <sup>***</sup>	Coil Volume ft <sup>3</sup>	Spray Pump		Remote Pump			Dimensions				
		HP	CFM	Shipping	Heaviest Section <sup>†</sup>	Operating			HP	GPM	Gallons Req'd <sup>**</sup>	Conn. Size	Operating Weight	Height H	Upper U	Lower E	Coil A	Length L
ATC-170E	121	5	29,700	7,730	6,430	10,310	183	25	2	340	220	8"	9,210	11' 2-3/4"	7' 2-1/2"	4' 1/4"	27"	8' 5-1/2"
ATC-187E	133	7.5	34,000	7,780	6,480	10,360	183	25	2	340	220	8"	9,260	11' 2-3/4"	7' 2-1/2"	4' 1/4"	27"	8' 5-1/2"
ATC-199E	141	10	37,200	7,790	6,490	10,370	183	25	2	340	220	8"	9,270	11' 2-3/4"	7' 2-1/2"	4' 1/4"	27"	8' 5-1/2"
ATC-221E	157	10	36,100	8,830	7,530	11,490	226	31	2	340	220	8"	10,390	11' 10-1/4"	7' 10"	4' 1/4"	34-1/2"	8' 5-1/2"
ATC-238E	169	15	40,500	8,960	7,660	11,620	226	31	2	340	220	8"	10,520	11' 10-1/4"	7' 10"	4' 1/4"	34-1/2"	8' 5-1/2"
ATC-247E	175	15	39,200	9,990	8,690	12,730	269	37	2	340	220	8"	11,630	12' 5-3/4"	8' 5-1/2"	4' 1/4"	42"	8' 5-1/2"

\* Tons at standard conditions: 96.3°F condensing, 20°F suction and 78°F W.B.

\*\* Gallons shown is water in suspension in unit and piping. Allow for additional water in bottom of remote sump to cover pump suction and strainer during operation. (12" would normally be sufficient.)

† Heaviest section is the coil section. **When 5.12g seismic design is required consult the factory for specific weights.**

\*\*\* Refrigerant charge is shown for R-717. Multiply by 1.93 for R-22 and 1.98 for R-134a.

Dimensions are subject to change. Do not use for pre-fabrication. Quantity of coil connections subject to change based on refrigerant and design conditions.

# Engineering Dimensions & Data

## Models ATC-218E to 473E

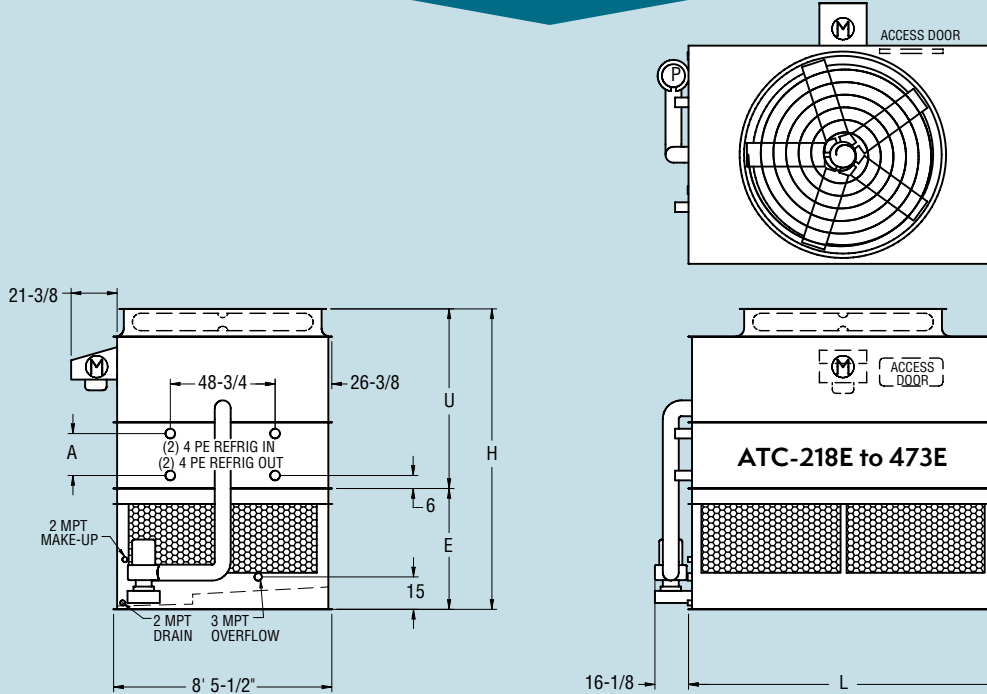

**Table 16 Engineering Data**

Model No.	R-717 Tons <sup>a</sup>	Fans		Weights <sup>†</sup>			Refrigerant Operating Charge lbs. <sup>***</sup>	Coil Volume ft <sup>3</sup>	Spray Pump		Remote Pump			Dimensions				
		HP	CFM	Shipping	Heaviest Section <sup>†</sup>	Operating			HP	GPM	Gallons Req'd <sup>**</sup>	Conn. Size	Operating Weight	Height H	Upper U	Lower E	Coil A	Length L
ATC-218E	155	7.5	38,400	9,190	7,750	12,210	210	29	2	410	250	8"	10,930	11'10-7/8"	7'7"	4'3-7/8"	27"	8'11-1/2"
ATC-233E	166	10	42,200	9,200	7,760	12,220	210	29	2	410	250	8"	10,940	11'10-7/8"	7'7"	4'3-7/8"	27"	8'11-1/2"
ATC-253E	180	15	47,500	9,330	7,890	12,350	210	29	2	410	250	8"	11,070	11'10-7/8"	7'7"	4'3-7/8"	27"	8'11-1/2"
ATC-258E	183	10	40,900	10,460	9,020	13,570	260	35	2	410	250	8"	12,290	12'6-3/8"	8'2-1/2"	4'3-7/8"	34-1/2"	8'11-1/2"
ATC-280E	199	15	46,100	10,590	9,150	13,700	260	35	2	410	250	8"	12,420	12'6-3/8"	8'2-1/2"	4'3-7/8"	34-1/2"	8'11-1/2"
ATC-305E	217	20	48,400	11,880	10,440	15,090	309	42	2	410	250	8"	13,810	13'1-7/8"	8'10"	4'3-7/8"	42"	8'11-1/2"
ATC-246E	175	15	54,700	9,370	7,730	12,820	187	25	3	500	290	10"	11,310	11'3-3/8"	6'11-1/2"	4'3-7/8"	19-1/2"	10'5-1/2"
ATC-269E	191	10	46,800	10,600	8,960	14,160	244	33	3	500	290	10"	12,650	11'10-7/8"	7'7"	4'3-7/8"	27"	10'5-1/2"
ATC-294E	209	15	53,100	10,720	9,080	14,280	244	33	3	500	290	10"	12,770	11'10-7/8"	7'7"	4'3-7/8"	27"	10'5-1/2"
ATC-325E	231	15	51,500	12,210	10,570	15,880	302	41	3	500	290	10"	14,370	12'6-3/8"	8'2-1/2"	4'3-7/8"	34-1/2"	10'5-1/2"
ATC-355E	252	20	54,100	13,700	12,060	17,480	359	49	3	500	290	10"	15,970	13'1-7/8"	8'10"	4'3-7/8"	42"	10'5-1/2"
ATC-369E	262	25	57,600	13,730	12,090	17,510	359	49	3	500	290	10"	16,000	13'1-7/8"	8'10"	4'3-7/8"	42"	10'5-1/2"
ATC-358E	255	15	56,800	13,230	11,430	17,530	344	47	3	550	330	10"	15,820	12'10-3/4"	8'2-1/2"	4'8-1/4"	34-1/2"	11'11-3/4"
ATC-371E	263	15	55,000	14,870	13,070	19,290	410	56	3	550	330	10"	17,580	13'6-1/4"	8'10"	4'8-1/4"	42"	11'11-3/4"
ATC-379E	269	20	61,500	13,290	11,490	17,590	344	47	3	550	330	10"	15,880	12'10-3/4"	8'2-1/2"	4'8-1/4"	34-1/2"	11'11-3/4"
ATC-392E	278	20	59,700	14,930	13,130	19,350	410	56	3	550	330	10"	17,640	13'6-1/4"	8'10"	4'8-1/4"	42"	11'11-3/4"
ATC-409E	290	25	63,500	14,960	13,160	19,380	410	56	3	550	330	10"	17,670	13'6-1/4"	8'10"	4'8-1/4"	42"	11'11-3/4"
ATC-385E	274	20	71,000	13,250	11,240	18,090	323	44	3	600	380	10"	16,130	12'3-1/4"	7'7"	4'8-1/4"	27"	13'11-3/4"
ATC-398E	283	15	63,000	15,030	13,020	20,020	400	54	3	600	380	10"	18,060	12'10-3/4"	8'2-1/2"	4'8-1/4"	34-1/2"	13'11-3/4"
ATC-423E	301	20	68,800	15,090	13,080	20,080	400	54	3	600	380	10"	18,120	12'10-3/4"	8'2-1/2"	4'8-1/4"	34-1/2"	13'11-3/4"
ATC-442E	313	25	73,300	15,120	13,110	20,110	400	54	3	600	380	10"	18,150	12'10-3/4"	8'2-1/2"	4'8-1/4"	34-1/2"	13'11-3/4"
ATC-457E	324	25	71,000	17,020	15,010	22,160	477	65	3	600	380	10"	20,200	13'6-1/4"	8'10"	4'8-1/4"	42"	13'11-3/4"
ATC-473E	336	30	74,700	17,070	15,060	22,210	477	65	3	600	380	10"	20,250	13'6-1/4"	8'10"	4'8-1/4"	42"	13'11-3/4"

<sup>a</sup> Tons at standard conditions: 96.3°F condensing, 20°F suction and 78°F W.B.

<sup>\*\*</sup> Gallons shown is water in suspension in unit and piping. Allow for additional water in bottom of remote sump to cover pump suction and strainer during operation. (12" would normally be sufficient.)

<sup>†</sup> Heaviest section is the coil section. **When 5.12g seismic design is required consult the factory for specific weights.**

<sup>\*\*\*</sup> Refrigerant charge is shown for R-717. Multiply by 1.93 for R-22 and 1.98 for R-134a.

Dimensions are subject to change. Do not use for pre-fabrication. Quantity of coil connections subject to change based on refrigerant and design conditions.

# Engineering Dimensions & Data

## Models ATC-486E to 755E

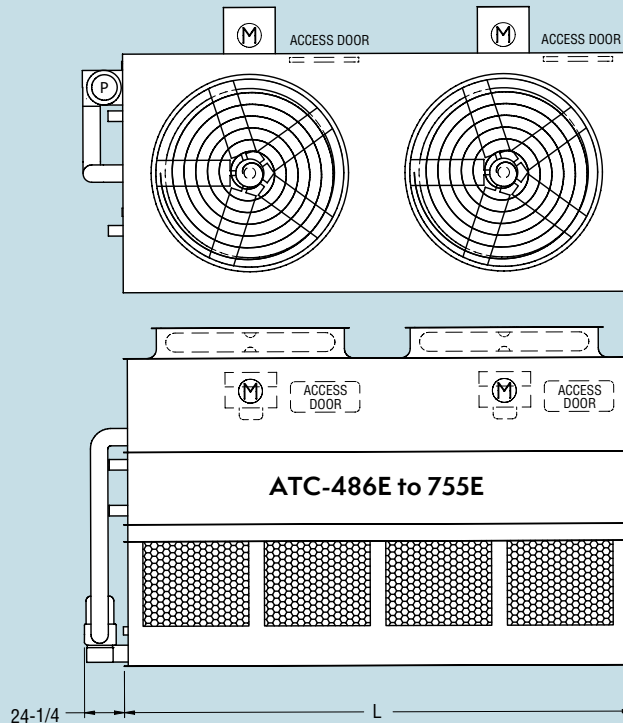
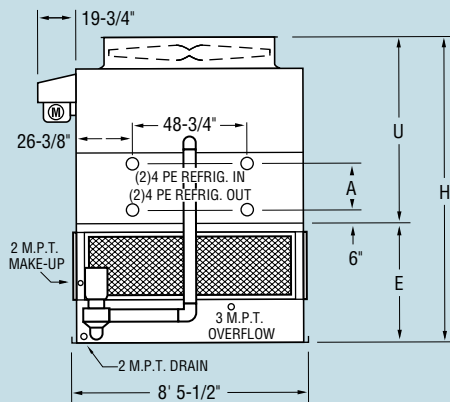

**Table 17 Engineering Data**

Model No.	R-717 Tons <sup>*</sup>	Fans		Weights <sup>†</sup>			Refrigerant Operating Charge lbs. <sup>***</sup>	Coil Volume ft <sup>3</sup>	Spray Pump		Remote Pump			Dimensions				
		HP	CFM	Shipping	Heaviest Section <sup>†</sup>	Operating			HP	GPM	Gallons Req'd <sup>**</sup>	Conn. Size	Operating Weight	Height H	Upper U	Lower E	Coil A	Length L
ATC-486E	345	(2) 10	84,800	17,630	14,840	23,930	412	56	5	800	510	12"	21,380	12' 7-1/4"	7' 7"	5' 1/4"	27"	18' 0"
ATC-527E	374	(2) 15	95,300	17,880	15,090	24,180	412	56	5	800	510	12"	21,630	12' 7-1/4"	7' 7"	5' 1/4"	27"	18' 0"
ATC-578E	411	(2) 15	92,500	20,200	17,410	26,690	512	70	5	800	510	12"	24,140	13' 2-3/4"	8' 2-1/2"	5' 1/4"	34-1/2"	18' 0"
ATC-598E	425	(2) 15	89,500	22,660	19,870	29,340	612	83	5	800	510	12"	26,790	13' 10-1/4"	8' 10"	5' 1/4"	42"	18' 0"
ATC-630E	447	(2) 20	97,100	22,780	19,990	29,460	612	83	5	800	510	12"	26,910	13' 10-1/4"	8' 10"	5' 1/4"	42"	18' 0"
ATC-508E	360	(2) 15	104,100	17,540	14,440	24,760	363	50	7-1/2	1050	590	12"	21,790	11' 11-3/4"	6' 11-1/2"	5' 1/4"	19-1/2"	21' 0"
ATC-557E	395	(2) 10	93,800	20,070	16,970	27,520	480	65	7-1/2	1050	590	12"	24,550	12' 7-1/4"	7' 7"	5' 1/4"	27"	21' 0"
ATC-609E	432	(2) 15	101,200	20,320	17,220	27,770	480	65	7-1/2	1050	590	12"	24,800	12' 7-1/4"	7' 7"	5' 1/4"	27"	21' 0"
ATC-666E	473	(2) 15	98,200	23,030	19,930	30,700	596	81	7-1/2	1050	590	12"	27,730	13' 2-3/4"	8' 2-1/2"	5' 1/4"	34-1/2"	21' 0"
ATC-687E	488	(2) 15	95,100	25,880	22,780	33,770	713	97	7-1/2	1050	590	12"	30,800	13' 10-1/4"	8' 10"	5' 1/4"	42"	21' 0"
ATC-703E	499	(2) 20	103,400	23,150	20,050	30,820	596	81	7-1/2	1050	590	12"	27,850	13' 2-3/4"	8' 2-1/2"	5' 1/4"	34-1/2"	21' 0"
ATC-725E	515	(2) 20	100,100	26,000	22,900	33,890	713	97	7-1/2	1050	590	12"	30,920	13' 10-1/4"	8' 10"	5' 1/4"	42"	21' 0"
ATC-755E	536	(2) 25	108,600	26,060	22,960	33,950	713	97	7-1/2	1050	590	12"	30,980	13' 10-1/4"	8' 10"	5' 1/4"	42"	21' 0"

\* Tons at standard conditions: 96.3°F condensing, 20°F suction and 78°F W.B.

\*\* Gallons shown is water in suspension in unit and piping. Allow for additional water in bottom of remote sump to cover pump suction and strainer during operation. (12" would normally be sufficient.)

† Heaviest section is the coil section. **When 5.12g seismic design is required consult the factory for specific weights.**

\*\*\* Refrigerant charge is shown for R-717. Multiply by 1.93 for R-22 and 1.98 for R-134a.

Dimensions are subject to change. Do not use for pre-fabrication. Quantity of coil connections subject to change based on refrigerant and design conditions.

# Engineering Dimensions & Data

## Models ATC-643E to 950E

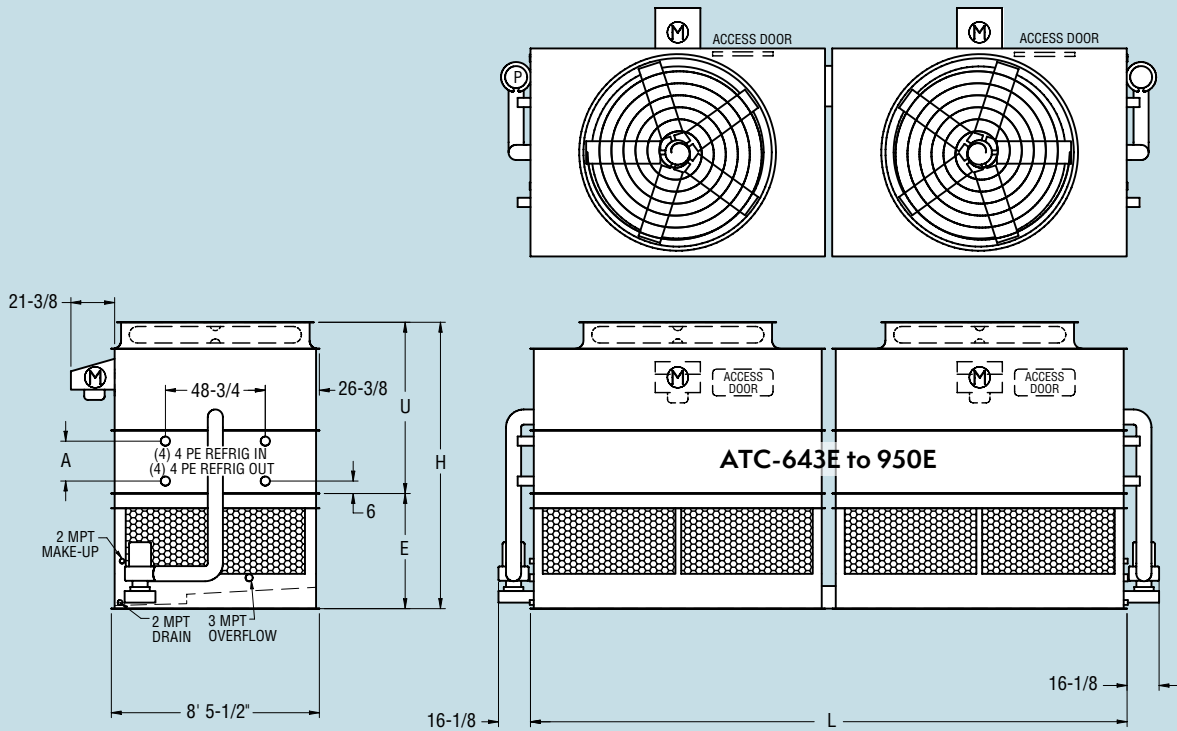

**Table 18 Engineering Data**

Model No.	R-717 Tons*	Fans		Weights†			Refrigerant Operating Charge lbs.**	Coil Volume ft <sup>3</sup>	Spray Pump		Remote Pump		Dimensions					
		HP	CFM	Shipping	Heaviest Section†	Operating			HP	GPM	Gallons Req'd**	Conn. Size	Operating Weight	Height H	Upper U	Lower E	Coil A	Length L
ATC-643E	456	(2) 15	116,500	23,300	9,850	31,640	556	76	(2) 3	1100	660	(2) 10"	28,220	12' 7-1/4"	7' 7"	5' 1/4"	27"	24' 2"
ATC-679E	482	(2) 20	126,300	23,420	9,910	31,760	556	76	(2) 3	1100	660	(2) 10"	28,340	12' 7-1/4"	7' 7"	5' 1/4"	27"	24' 2"
ATC-710E	504	(2) 15	113,000	26,460	11,430	35,060	688	94	(2) 3	1100	660	(2) 10"	31,640	13' 2-3/4"	8' 2-1/2"	5' 1/4"	34-1/2"	24' 2"
ATC-750E	532	(2) 20	122,400	26,580	11,490	35,180	688	94	(2) 3	1100	660	(2) 10"	31,760	13' 2-3/4"	8' 2-1/2"	5' 1/4"	34-1/2"	24' 2"
ATC-782E	555	(2) 25	130,400	26,640	11,520	35,240	688	94	(2) 3	1100	660	(2) 10"	31,820	13' 2-3/4"	8' 2-1/2"	5' 1/4"	34-1/2"	24' 2"
ATC-809E	574	(2) 25	126,300	29,920	13,160	38,760	819	112	(2) 3	1100	660	(2) 10"	35,340	13' 10-1/4"	8' 10"	5' 1/4"	42"	24' 2"
ATC-800E	568	(2) 15	127,400	30,060	13,020	40,040	800	109	(2) 3	1200	760	(2) 10"	36,120	13' 8-3/4"	8' 2-1/2"	5' 6-1/4"	34-1/2"	28' 2"
ATC-828E	588	(2) 15	123,500	33,860	14,920	44,140	954	130	(2) 3	1200	760	(2) 10"	40,220	14' 4-1/4"	8' 10"	5' 6-1/4"	42"	28' 2"
ATC-851E	604	(2) 20	139,000	30,180	13,080	40,160	800	109	(2) 3	1200	760	(2) 10"	36,240	13' 8-3/4"	8' 2-1/2"	5' 6-1/4"	34-1/2"	28' 2"
ATC-887E	630	(2) 25	148,000	30,240	13,110	40,220	800	109	(2) 3	1200	760	(2) 10"	36,300	13' 8-3/4"	8' 2-1/2"	5' 6-1/4"	34-1/2"	28' 2"
ATC-918E	652	(2) 25	143,400	34,040	15,010	44,320	954	130	(2) 3	1200	760	(2) 10"	40,400	14' 4-1/4"	8' 10"	5' 6-1/4"	42"	28' 2"
ATC-950E	674	(2) 30	150,900	34,140	15,060	44,420	954	130	(2) 3	1200	760	(2) 10"	40,500	14' 4-1/4"	8' 10"	5' 6-1/4"	42"	28' 2"

\* Tons at standard conditions: 96.3°F condensing, 20°F suction and 78°F W.B.

\*\* Gallons shown is water in suspension in unit and piping. Allow for additional water in bottom of remote sump to cover pump suction and strainer during operation. (12" would normally be sufficient.)

† Heaviest section is the coil section. **When 5.12g seismic design is required consult the factory for specific weights.**

\*\*\* Refrigerant charge is shown for R-717. Multiply by 1.93 for R-22 and 1.98 for R-134a.

Dimensions are subject to change. Do not use for pre-fabrication. Quantity of coil connections subject to change based on refrigerant and design conditions.

# Engineering Dimensions & Data

## Models ATC-639E to 926E

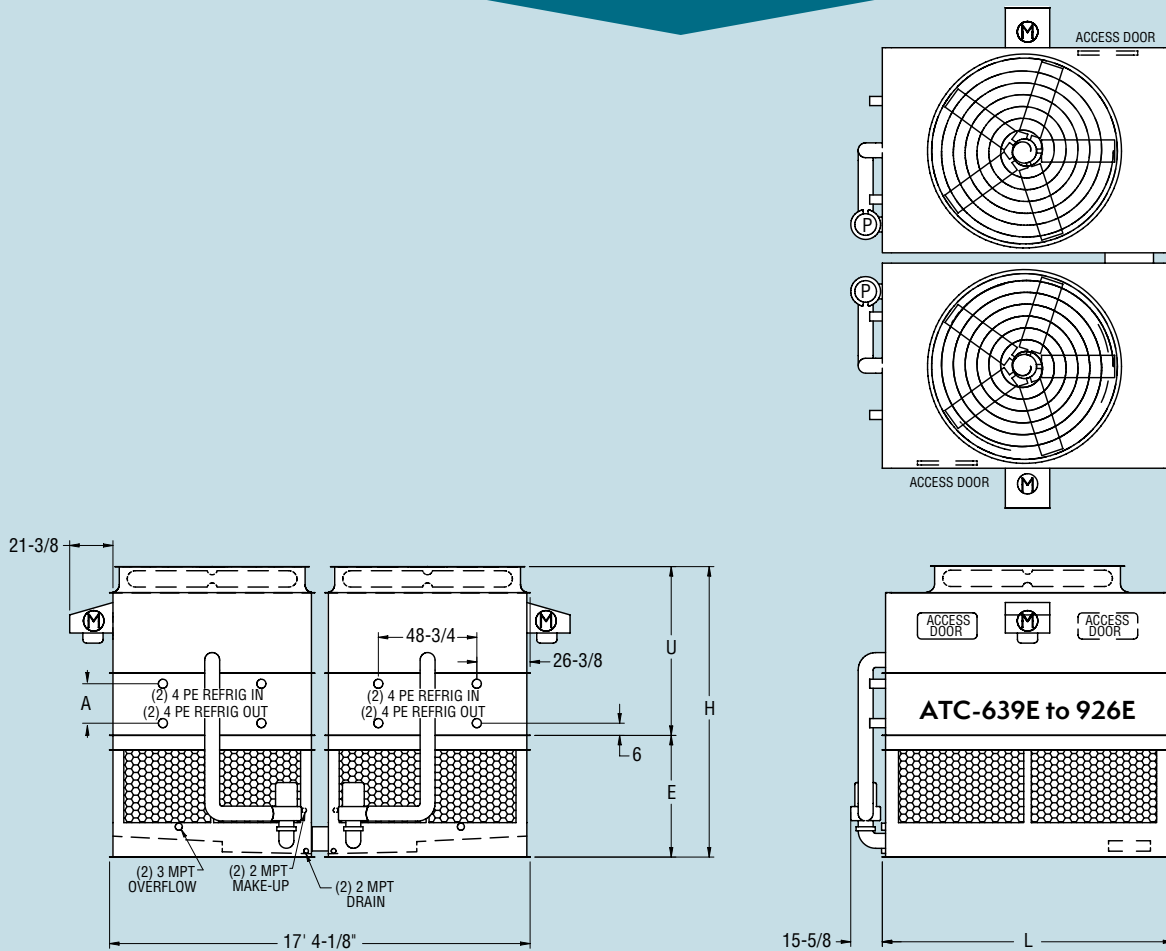

**Table 19 Engineering Data**

Model No.	R-717 Tons*	Fans		Weights†			Refrigerant Operating Charge lbs.**	Coil Volume ft <sup>3</sup>	Spray Pump		Remote Pump		Dimensions					
		HP	CFM	Shipping	Heaviest Section†	Operating			HP	GPM	Gallons Req'd**	Conn. Size	Operating Weight	Height H	Upper U	Lower E	Coil A	Length L
ATC-639E	454	(2) 15	115,900	23,300	9,850	31,640	556	76	(2) 3	1100	660	(2) 10"	28,220	12' 7-1/4"	7' 7"	5' 1/4"	27"	11' 11-3/4"
ATC-675E	479	(2) 20	125,700	23,420	9,910	31,760	556	76	(2) 3	1100	660	(2) 10"	28,340	12' 7-1/4"	7' 7"	5' 1/4"	27"	11' 11-3/4"
ATC-706E	501	(2) 15	112,500	26,460	11,430	35,060	688	94	(2) 3	1100	660	(2) 10"	31,640	13' 2-3/4"	8' 2-1/2"	5' 1/4"	34-1/2"	11' 11-3/4"
ATC-746E	530	(2) 20	121,800	26,580	11,490	35,180	688	94	(2) 3	1100	660	(2) 10"	31,760	13' 2-3/4"	8' 2-1/2"	5' 1/4"	34-1/2"	11' 11-3/4"
ATC-778E	553	(2) 25	129,800	26,640	11,520	35,240	688	94	(2) 3	1100	660	(2) 10"	31,820	13' 2-3/4"	8' 2-1/2"	5' 1/4"	34-1/2"	11' 11-3/4"
ATC-805E	571	(2) 25	125,700	29,920	13,160	38,760	819	112	(2) 3	1100	660	(2) 10"	35,340	13' 10-1/4"	8' 10"	5' 1/4"	42"	11' 11-3/4"
ATC-780E	554	(2) 15	124,800	30,060	13,020	40,040	800	109	(2) 3	1200	760	(2) 10"	36,120	13' 8-3/4"	8' 2-1/2"	5' 6-1/4"	34-1/2"	13' 11-3/4"
ATC-830E	589	(2) 20	136,200	30,180	13,080	40,160	800	109	(2) 3	1200	760	(2) 10"	36,240	13' 8-3/4"	8' 2-1/2"	5' 6-1/4"	34-1/2"	13' 11-3/4"
ATC-865E	614	(2) 25	145,000	30,240	13,110	40,220	800	109	(2) 3	1200	760	(2) 10"	36,300	13' 8-3/4"	8' 2-1/2"	5' 6-1/4"	34-1/2"	13' 11-3/4"
ATC-895E	636	(2) 25	140,500	34,040	15,010	44,320	954	130	(2) 3	1200	760	(2) 10"	40,400	14' 4-1/4"	8' 10"	5' 6-1/4"	42"	13' 11-3/4"
ATC-926E	658	(2) 30	147,900	34,140	15,060	44,420	954	130	(2) 3	1200	760	(2) 10"	40,500	14' 4-1/4"	8' 10"	5' 6-1/4"	42"	13' 11-3/4"

\* Tons at standard conditions: 96.3°F condensing, 20°F suction and 78°F W.B.

\*\* Gallons shown is water in suspension in unit and piping. Allow for additional water in bottom of remote sump to cover pump suction and strainer during operation. (12" would normally be sufficient.)

† Heaviest section is the coil section. **When 5.12g seismic design is required consult the factory for specific weights.**

\*\*\* Refrigerant charge is shown for R-717. Multiply by 1.93 for R-22 and 1.98 for R-134a.

Dimensions are subject to change. Do not use for pre-fabrication. Quantity of coil connections subject to change based on refrigerant and design conditions.



# Engineering Dimensions & Data

## Models ATC-XE298E to XC462E

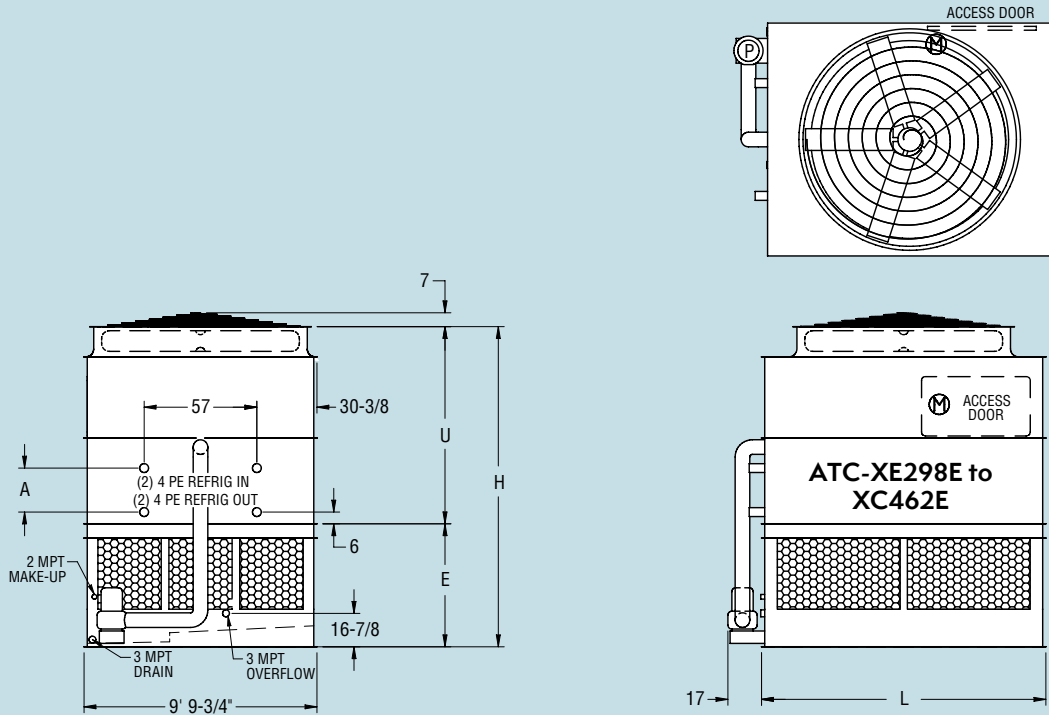

**Table 20 Engineering Data**

Model No.	R-717 Tons*	Fans		Weights†			Refrigerant Operating Charge lbs.**	Coil Volume ft <sup>3</sup>	Spray Pump		Remote Pump			Dimensions				
		HP	CFM	Shipping	Heaviest Section†	Operating			HP	GPM	Gallons Req'd**	Conn. Size	Operating Weight	Height H	Upper U	Lower E	Coil A	Length L
ATC-XE298E	211	10	55,500	12,390	9,840	18,260	249	34	5	685	420	12"	14,690	13' 5-7/8"	8' 3-5/8"	5' 2-1/4"	22-1/4"	11' 11-3/4"
ATC-XE333E	236	10	54,700	14,270	11,720	20,290	326	44	5	685	420	12"	16,720	14' 2-3/8"	9' 1/8"	5' 2-1/4"	30-3/4"	11' 11-3/4"
ATC-XC346E	245	20	70,000	12,580	10,030	18,450	249	34	5	685	420	12"	14,880	13' 5-7/8"	8' 3-5/8"	5' 2-1/4"	22-1/4"	11' 11-3/4"
ATC-XE356E	252	10	53,900	16,050	13,500	22,220	404	55	5	685	420	12"	18,650	14' 10-7/8"	9' 8-5/8"	5' 2-1/4"	39-1/4"	11' 11-3/4"
ATC-XC360E	255	25	75,400	12,610	10,060	18,480	249	34	5	685	420	12"	14,910	13' 5-7/8"	8' 3-5/8"	5' 2-1/4"	22-1/4"	11' 11-3/4"
ATC-XE368E	261	10	53,100	17,970	15,420	24,290	481	66	5	685	420	12"	20,720	15' 7-3/8"	10' 5-1/8"	5' 2-1/4"	47-3/4"	11' 11-3/4"
ATC-XE387E	274	15	61,700	16,180	13,630	22,350	404	55	5	685	420	12"	18,780	14' 10-7/8"	9' 8-5/8"	5' 2-1/4"	39-1/4"	11' 11-3/4"
ATC-XC388E	275	20	68,900	14,460	11,910	20,480	326	44	5	685	420	12"	16,910	14' 2-3/8"	9' 1/8"	5' 2-1/4"	30-3/4"	11' 11-3/4"
ATC-XC402E	285	25	74,200	14,490	11,940	20,510	326	44	5	685	420	12"	16,940	14' 2-3/8"	9' 1/8"	5' 2-1/4"	30-3/4"	11' 11-3/4"
ATC-XC427E	303	25	73,100	16,270	13,720	22,440	404	55	5	685	420	12"	18,870	14' 10-7/8"	9' 8-5/8"	5' 2-1/4"	39-1/4"	11' 11-3/4"
ATC-XC443E	314	30	77,700	16,320	13,770	22,490	404	55	5	685	420	12"	18,920	14' 10-7/8"	9' 8-5/8"	5' 2-1/4"	39-1/4"	11' 11-3/4"
ATC-XC462E	328	30	76,600	18,240	15,690	24,560	481	66	5	685	420	12"	20,990	15' 7-3/8"	10' 5-1/8"	5' 2-1/4"	47-3/4"	11' 11-3/4"

\* Tons at standard conditions: 96.3°F condensing, 20°F suction and 78°F W.B.

\*\* Gallons shown is water in suspension in unit and piping. Allow for additional water in bottom of remote sump to cover pump suction and strainer during operation. (12" would normally be sufficient.)

† Heaviest section is the coil section. **When 5.12g seismic design is required consult the factory for specific weights.**

\*\*\* Refrigerant charge is shown for R-717. Multiply by 1.93 for R-22 and 1.98 for R-134a.

Dimensions are subject to change. Do not use for pre-fabrication. Quantity of coil connections subject to change based on refrigerant and design conditions.

# Engineering Dimensions & Data

## Models ATC-XE406E to XC669E

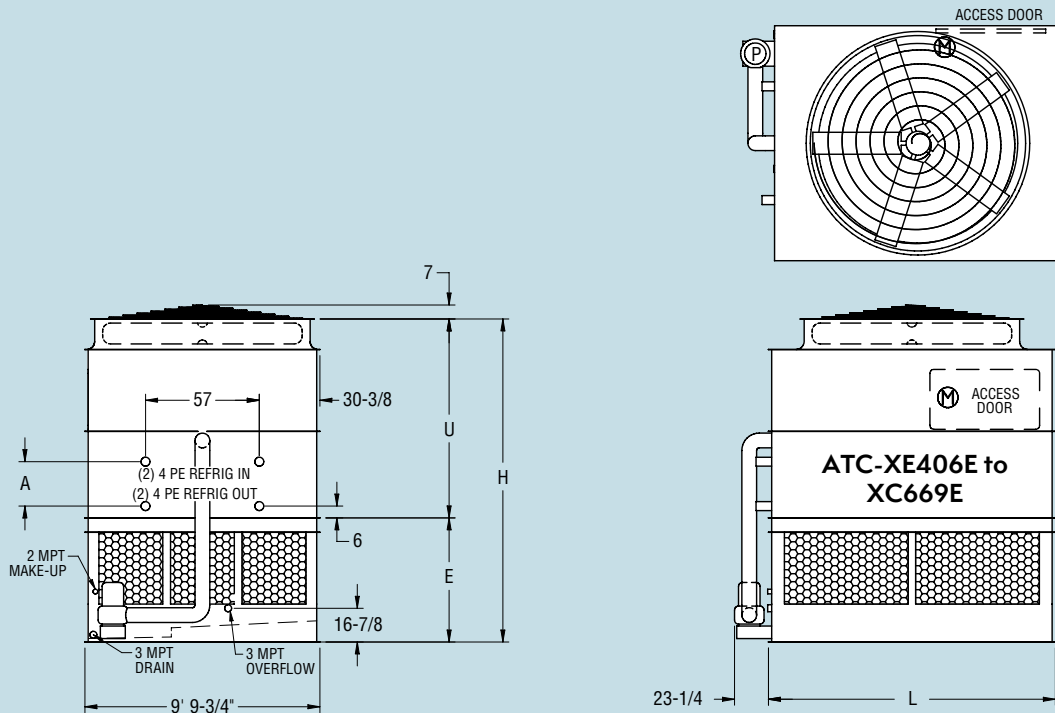

**Table 21 Engineering Data**

Model No.	R-717 Tons <sup>*</sup>	Fans		Weights <sup>†</sup>			Refrigerant Operating Charge lbs. <sup>***</sup>	Coil Volume ft <sup>3</sup>	Spray Pump		Remote Pump			Dimensions				
		HP	CFM	Shipping	Heaviest Section <sup>†</sup>	Operating			HP	GPM	Gallons Req'd <sup>**</sup>	Conn. Size	Operating Weight	Height H	Upper U	Lower E	Coil A	Length L
ATC-XE406E	288	10	74,400	17,630	13,980	26,490	367	50	7-1/2	1030	630	12"	21,240	13' 5-7/8"	8' 3-5/8"	5' 2-1/4"	22-1/4"	18' 0"
ATC-XE448E	318	10	73,300	20,420	16,770	29,510	484	66	7-1/2	1030	630	12"	24,260	14' 2-3/8"	9' 1/8"	5' 2-1/4"	30-3/4"	18' 0"
ATC-XE472E	335	10	72,200	23,130	19,480	32,440	601	82	7-1/2	1030	630	12"	27,190	14' 10-7/8"	9' 8-5/8"	5' 2-1/4"	39-1/4"	18' 0"
ATC-XE492E	349	15	83,900	20,550	16,900	29,640	484	66	7-1/2	1030	630	12"	24,390	14' 2-3/8"	9' 1/8"	5' 2-1/4"	30-3/4"	18' 0"
ATC-XC504E	357	25	100,900	17,850	14,200	26,710	367	50	7-1/2	1030	630	12"	21,460	13' 5-7/8"	8' 3-5/8"	5' 2-1/4"	22-1/4"	18' 0"
ATC-XE516E	366	15	82,600	23,260	19,610	32,570	601	82	7-1/2	1030	630	12"	27,320	14' 10-7/8"	9' 8-5/8"	5' 2-1/4"	39-1/4"	18' 0"
ATC-XC525E	372	30	107,200	17,900	14,250	26,760	367	50	7-1/2	1030	630	12"	21,510	13' 5-7/8"	8' 3-5/8"	5' 2-1/4"	22-1/4"	18' 0"
ATC-XE528E	374	20	92,300	20,610	16,960	29,700	484	66	7-1/2	1030	630	12"	24,450	14' 2-3/8"	9' 1/8"	5' 2-1/4"	30-3/4"	18' 0"
ATC-XE542E	384	15	81,400	26,120	22,470	35,650	718	98	7-1/2	1030	630	12"	30,400	15' 7-3/8"	10' 5-1/8"	5' 2-1/4"	47-3/4"	18' 0"
ATC-XE553E	392	20	90,900	23,320	19,670	32,630	601	82	7-1/2	1030	630	12"	27,380	14' 10-7/8"	9' 8-5/8"	5' 2-1/4"	39-1/4"	18' 0"
ATC-XC558E	396	25	99,400	20,640	16,990	29,730	484	66	7-1/2	1030	630	12"	24,480	14' 2-3/8"	9' 1/8"	5' 2-1/4"	30-3/4"	18' 0"
ATC-XC579E	411	25	98,000	23,350	19,700	32,660	601	82	7-1/2	1030	630	12"	27,410	14' 10-7/8"	9' 8-5/8"	5' 2-1/4"	39-1/4"	18' 0"
ATC-XE608E	431	25	96,500	26,210	22,560	35,740	718	98	7-1/2	1030	630	12"	30,490	15' 7-3/8"	10' 5-1/8"	5' 2-1/4"	47-3/4"	18' 0"
ATC-XC611E	433	40	116,300	20,850	17,200	29,940	484	66	7-1/2	1030	630	12"	24,690	14' 2-3/8"	9' 1/8"	5' 2-1/4"	30-3/4"	18' 0"
ATC-XC641E	455	40	114,600	23,560	19,910	32,870	601	82	7-1/2	1030	630	12"	27,620	14' 10-7/8"	9' 8-5/8"	5' 2-1/4"	39-1/4"	18' 0"
ATC-XC669E	474	40	112,900	26,420	22,770	35,950	718	98	7-1/2	1030	630	12"	30,700	15' 7-3/8"	10' 5-1/8"	5' 2-1/4"	47-3/4"	18' 0"

\* Tons at standard conditions: 96.3°F condensing, 20°F suction and 78°F W.B.

\*\* Gallons shown is water in suspension in unit and piping. Allow for additional water in bottom of remote sump to cover pump suction and strainer during operation. (12" would normally be sufficient.)

† Heaviest section is the coil section. **When 5.12g seismic design is required consult the factory for specific weights.**

\*\*\* Refrigerant charge is shown for R-717. Multiply by 1.93 for R-22 and 1.98 for R-134a.

Dimensions are subject to change. Do not use for pre-fabrication. Quantity of coil connections subject to change based on refrigerant and design conditions. Optional Dual Fan units will have a "-DF" at the end of the model number. Fan horsepower and weights may vary.

# Engineering Dimensions & Data

## Models ATC-XE596E to XC925E

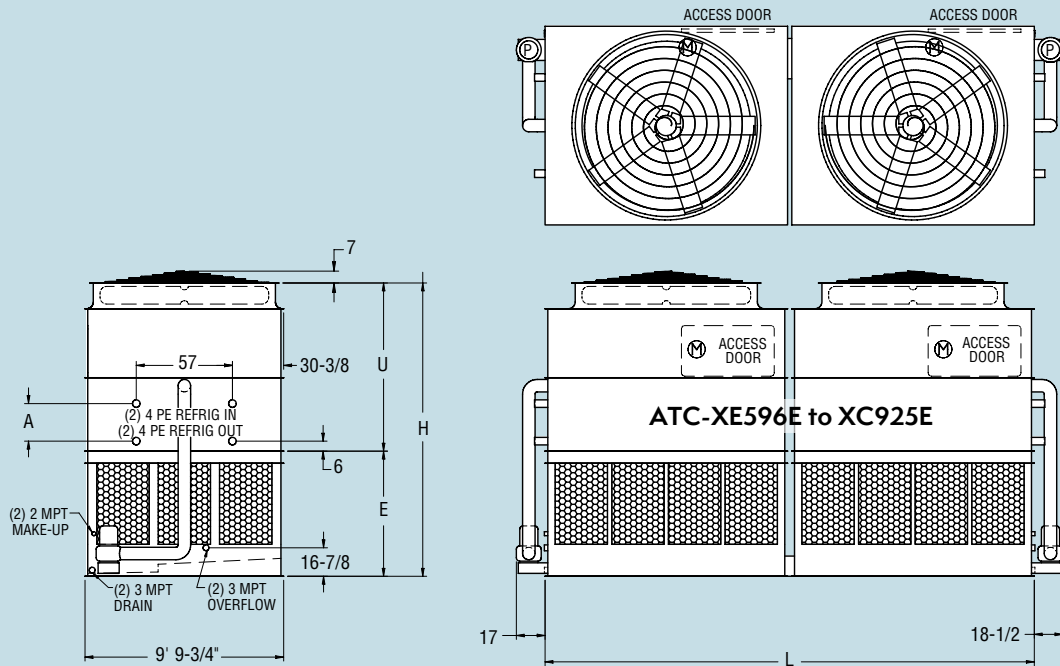

**Table 22 Engineering Data**

Model No.	R-717 Tons*	Fans		Weights†			Refrigerant Operating Charge lbs.**	Coil Volume ft <sup>3</sup>	Spray Pump		Remote Pump			Dimensions				
		HP	CFM	Shipping	Heaviest Section†	Operating			HP	GPM	Gallons Req'd**	Conn. Size	Operating Weight	Height H	Upper U	Lower E	Coil A	Length L
ATC-XE596E	423	(2) 10	111,000	25,040	9,840	36,780	497	68	(2) 5	1370	840	(2) 12"	29,640	14' 5-7/8"	8' 3-5/8"	6' 2-1/4"	22-1/4"	24' 2"
ATC-XE665E	472	(2) 10	109,400	28,800	11,720	40,840	652	89	(2) 5	1370	840	(2) 12"	33,700	15' 2-3/8"	9' 1/8"	6' 2-1/4"	30-3/4"	24' 2"
ATC-XE709E	503	(2) 10	107,800	32,360	13,500	44,700	807	110	(2) 5	1370	840	(2) 12"	37,560	15' 10-7/8"	9' 8-5/8"	6' 2-1/4"	39-1/4"	24' 2"
ATC-XC720E	511	(2) 25	150,700	25,480	10,060	37,220	497	68	(2) 5	1370	840	(2) 12"	30,080	14' 5-7/8"	8' 3-5/8"	6' 2-1/4"	22-1/4"	24' 2"
ATC-XE742E	526	(2) 10	106,200	36,200	15,420	48,840	962	131	(2) 5	1370	840	(2) 12"	41,700	16' 7-3/8"	10' 5-1/8"	6' 2-1/4"	47-3/4"	24' 2"
ATC-XC775E	550	(2) 20	137,800	29,180	11,910	41,220	652	89	(2) 5	1370	840	(2) 12"	34,080	15' 2-3/8"	9' 1/8"	6' 2-1/4"	30-3/4"	24' 2"
ATC-XC804E	570	(2) 25	148,500	29,240	11,940	41,280	652	89	(2) 5	1370	840	(2) 12"	34,140	15' 2-3/8"	9' 1/8"	6' 2-1/4"	30-3/4"	24' 2"
ATC-XC855E	606	(2) 25	146,300	32,800	13,720	45,140	807	110	(2) 5	1370	840	(2) 12"	38,000	15' 10-7/8"	9' 8-5/8"	6' 2-1/4"	39-1/4"	24' 2"
ATC-XC884E	627	(2) 30	155,500	32,900	13,770	45,240	807	110	(2) 5	1370	840	(2) 12"	38,100	15' 10-7/8"	9' 8-5/8"	6' 2-1/4"	39-1/4"	24' 2"
ATC-XC897E	636	(2) 25	144,100	36,640	15,640	49,280	962	131	(2) 5	1370	840	(2) 12"	42,140	16' 7-3/8"	10' 5-1/8"	6' 2-1/4"	47-3/4"	24' 2"
ATC-XC925E	656	(2) 30	153,200	36,740	15,690	49,380	962	131	(2) 5	1370	840	(2) 12"	42,240	16' 7-3/8"	10' 5-1/8"	6' 2-1/4"	47-3/4"	24' 2"

\* Tons at standard conditions: 96.3°F condensing, 20°F suction and 78°F W.B.

\*\* Gallons shown is water in suspension in unit and piping. Allow for additional water in bottom of remote sump to cover pump suction and strainer during operation. (12" would normally be sufficient.)

† Heaviest section is the coil section. **When 5.12g seismic design is required consult the factory for specific weights.**

\*\*\* Refrigerant charge is shown for R-717. Multiply by 1.93 for R-22 and 1.98 for R-134a.

Dimensions are subject to change. Do not use for pre-fabrication. Quantity of coil connections subject to change based on refrigerant and design conditions.

# Engineering Dimensions & Data

## Models ATC-XE812E to XC1340E

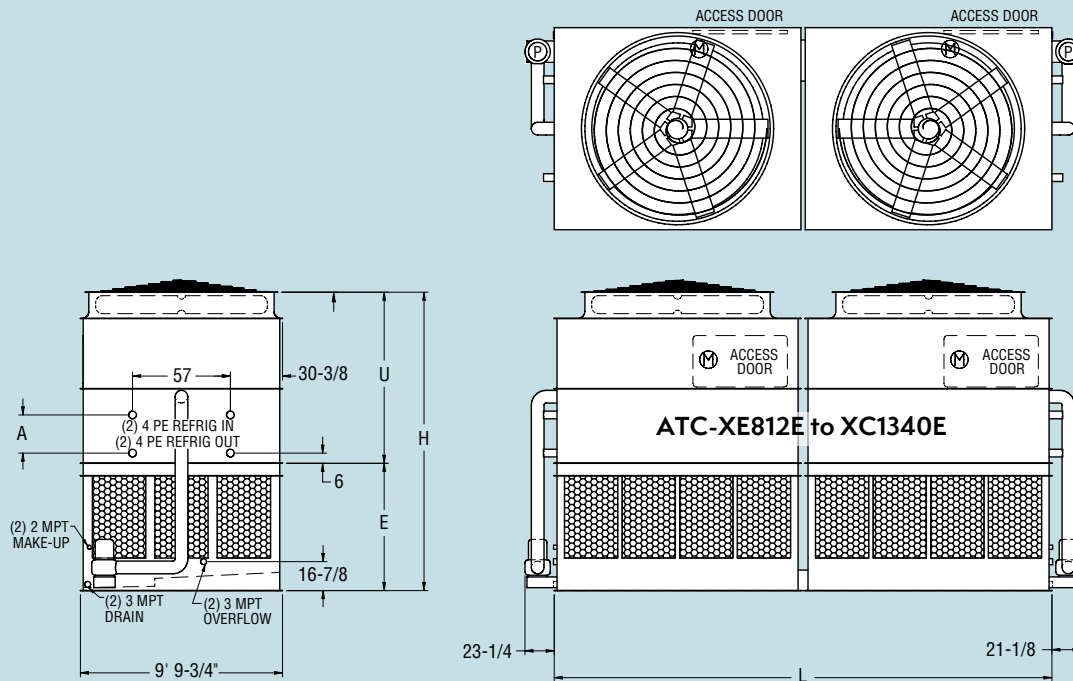

Table 23 Engineering Data

Model No.	R-717 Tons*	Fans		Weights†			Refrigerant Operating Charge lbs.***	Coil Volume ft <sup>3</sup>	Spray Pump		Remote Pump		Dimensions					
		HP	CFM	Shipping	Heaviest Section†	Operating			HP	GPM	Gallons Req'd**	Conn. Size	Operating Weight	Height H	Upper U	Lower E	Coil A	Length L
ATC-XE812E	576	[2]10	148,700	35,260	13,980	52,980	734	100	[2]7.5	2060	1260	[2]12"	42,480	14' 7/8"	8' 3-5/8"	6' 2-1/4"	22-1/4"	36' 2-1/2"
ATC-XE896E	635	[2]10	146,500	40,840	16,770	59,020	969	132	[2]7.5	2060	1260	[2]12"	48,520	15' 2-3/8"	9' 1/8"	6' 2-1/4"	30-3/4"	36' 2-1/2"
ATC-XE947E	672	[2]10	144,400	46,260	19,480	64,880	1203	164	[2]7.5	2060	1260	[2]12"	54,380	15' 10-7/8"	9' 8-5/8"	6' 2-1/4"	39-1/4"	36' 2-1/2"
ATC-XE984E	698	[2]15	167,700	41,100	16,900	59,280	969	132	[2]7.5	2060	1260	[2]12"	48,780	15' 2-3/8"	9' 1/8"	6' 2-1/4"	30-3/4"	36' 2-1/2"
ATC-XC1011E	717	[2]25	201,900	35,700	14,200	53,420	734	100	[2]7.5	2060	1260	[2]12"	42,920	14' 5-7/8"	8' 3-5/8"	6' 2-1/4"	22-1/4"	36' 2-1/2"
ATC-XE1032E	732	[2]15	165,300	46,520	19,610	65,140	1203	164	[2]7.5	2060	1260	[2]12"	54,640	15' 10-7/8"	9' 8-5/8"	6' 2-1/4"	39-1/4"	36' 2-1/2"
ATC-XC1049E	744	[2]30	214,500	35,800	14,250	53,520	734	100	[2]7.5	2060	1260	[2]12"	43,020	14' 5-7/8"	8' 3-5/8"	6' 2-1/4"	22-1/4"	36' 2-1/2"
ATC-XC1112E	789	[2]25	198,900	41,280	16,990	59,460	969	132	[2]7.5	2060	1260	[2]12"	48,960	15' 2-3/8"	9' 1/8"	6' 2-1/4"	30-3/4"	36' 2-1/2"
ATC-XC1153E	818	[2]30	211,300	41,380	17,040	59,560	969	132	[2]7.5	2060	1260	[2]12"	49,060	15' 2-3/8"	9' 1/8"	6' 2-1/4"	30-3/4"	36' 2-1/2"
ATC-XE1157E	821	[2]20	179,200	52,360	22,530	71,420	1437	196	[2]7.5	2060	1260	[2]12"	60,920	16' 7-3/8"	10' 5-1/8"	6' 2-1/4"	47-3/4"	36' 2-1/2"
ATC-XC1210E	858	[2]30	208,200	46,800	19,750	65,420	1203	164	[2]7.5	2060	1260	[2]12"	54,920	15' 10-7/8"	9' 8-5/8"	6' 2-1/4"	39-1/4"	36' 2-1/2"
ATC-XC1222E	867	[2]40	232,600	41,700	17,200	59,880	969	132	[2]7.5	2060	1260	[2]12"	49,380	15' 2-3/8"	9' 1/8"	6' 2-1/4"	30-3/4"	36' 2-1/2"
ATC-XC1264E	896	[2]30	205,100	52,520	22,610	71,580	1437	196	[2]7.5	2060	1260	[2]12"	61,080	16' 7-3/8"	10' 5-1/8"	6' 2-1/4"	47-3/4"	36' 2-1/2"
ATC-XC1282E	909	[2]40	229,200	47,120	19,910	65,740	1203	164	[2]7.5	2060	1260	[2]12"	55,240	15' 10-7/8"	9' 8-5/8"	6' 2-1/4"	39-1/4"	36' 2-1/2"
ATC-XC1340E	950	[2]40	225,800	52,840	22,770	71,900	1437	196	[2]7.5	2060	1260	[2]12"	61,400	16' 7-3/8"	10' 5-1/8"	6' 2-1/4"	47-3/4"	36' 2-1/2"

\* Tons at standard conditions: 96.3°F condensing, 20°F suction and 78°F W.B.

\*\* Gallons shown is water in suspension in unit and piping. Allow for additional water in bottom of remote sump to cover pump suction and strainer during operation. (12" would normally be sufficient.)

† Heaviest section is the coil section. **When 5.12g seismic design is required consult the factory for specific weights.**

\*\*\* Refrigerant charge is shown for R-717. Multiply by 1.93 for R-22 and 1.98 for R-134a.

Dimensions are subject to change. Do not use for pre-fabrication. Quantity of coil connections subject to change based on refrigerant and design conditions.

Optional Dual Fan units will have a "-DF" at the end of the model number. Fan horsepower and weights may vary.

# Engineering Dimensions & Data

## Models ATC-428E to 647E

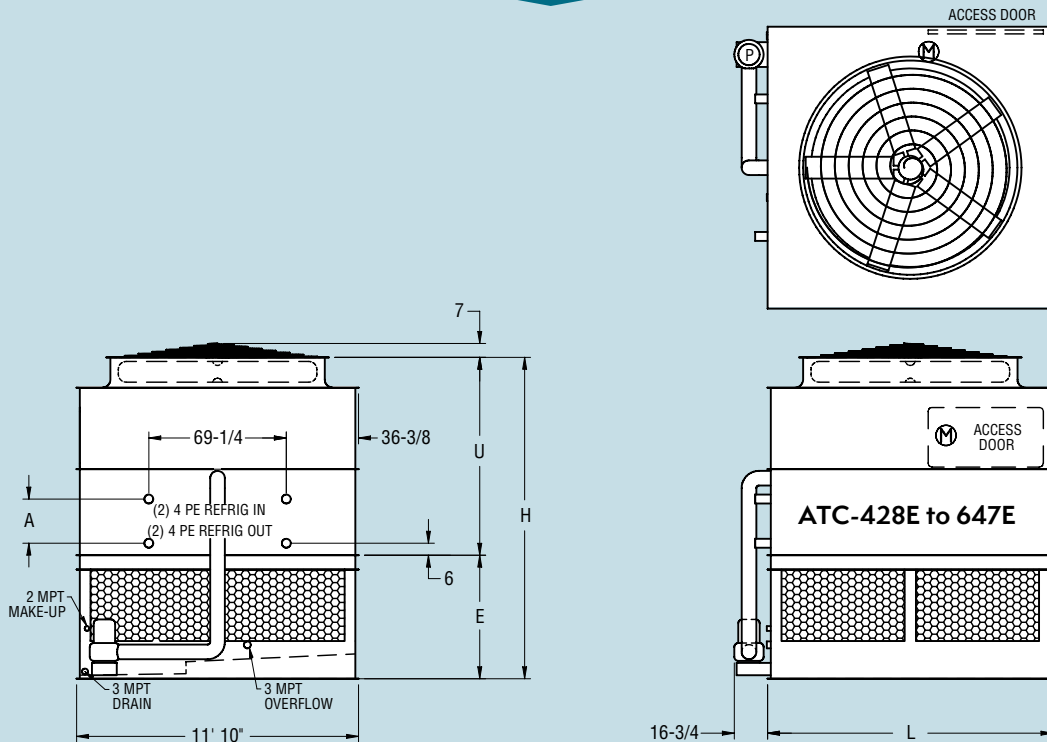

**Table 24 Engineering Data**

Model No.	R-717 Tons*	Fans		Weights†			Refrigerant Operating Charge lbs.***	Coil Volume ft <sup>3</sup>	Spray Pump		Remote Pump			Dimensions				
		HP	CFM	Shipping	Heaviest Section†	Operating			HP	GPM	Gallons Req'd**	Conn. Size	Operating Weight	Height H	Upper U	Lower E	Coil A	Length L
ATC-428E	304	15	73,800	16,560	13,850	23,360	401	55	5	800	490	12"	19,410	14' 2-3/8"	9' 1/8"	5' 2-1/4"	30-3/4"	11' 11-3/4"
ATC-456E	324	20	81,200	16,620	13,910	23,420	401	55	5	800	490	12"	19,470	14' 2-3/8"	9' 1/8"	5' 2-1/4"	30-3/4"	11' 11-3/4"
ATC-474E	337	25	86,600	16,650	13,940	23,450	401	55	5	800	490	12"	19,500	14' 2-3/8"	9' 1/8"	5' 2-1/4"	30-3/4"	11' 11-3/4"
ATC-503E	357	20	78,900	18,800	16,090	25,780	497	68	5	800	490	12"	21,830	14' 10-7/8"	9' 8-5/8"	5' 2-1/4"	39-1/4"	11' 11-3/4"
ATC-523E	371	25	84,000	18,830	16,120	25,810	497	68	5	800	490	12"	21,860	14' 10-7/8"	9' 8-5/8"	5' 2-1/4"	39-1/4"	11' 11-3/4"
ATC-539E	382	30	88,500	18,880	16,170	25,860	497	68	5	800	490	12"	21,910	14' 10-7/8"	9' 8-5/8"	5' 2-1/4"	39-1/4"	11' 11-3/4"
ATC-559E	397	30	85,700	21,240	18,530	28,400	593	81	5	800	490	12"	24,450	15' 7-3/8"	10' 5-1/8"	5' 2-1/4"	47-3/4"	11' 11-3/4"
ATC-583E	414	40	92,900	21,400	18,690	28,560	593	81	5	800	490	12"	24,610	15' 7-3/8"	10' 5-1/8"	5' 2-1/4"	47-3/4"	11' 11-3/4"
ATC-545E	387	30	101,900	18,940	15,880	26,940	466	64	5	900	570	12"	22,370	14' 8-3/8"	9' 1/8"	5' 8-1/4"	30-3/4"	13' 11-3/4"
ATC-556E	395	20	87,300	21,360	18,300	29,580	578	79	5	900	570	12"	25,010	15' 4-7/8"	9' 8-5/8"	5' 8-1/4"	39-1/4"	13' 11-3/4"
ATC-581E	413	25	94,000	21,390	18,330	29,610	578	79	5	900	570	12"	25,040	15' 4-7/8"	9' 8-5/8"	5' 8-1/4"	39-1/4"	13' 11-3/4"
ATC-601E	427	25	91,100	24,390	21,330	32,820	690	94	5	900	570	12"	28,250	16' 1-3/8"	10' 5-1/8"	5' 8-1/4"	47-3/4"	13' 11-3/4"
ATC-620E	440	30	95,800	24,440	21,380	32,870	690	94	5	900	570	12"	28,300	16' 1-3/8"	10' 5-1/8"	5' 8-1/4"	47-3/4"	13' 11-3/4"
ATC-647E	459	40	103,800	24,600	21,540	33,030	690	94	5	900	570	12"	28,460	16' 1-3/8"	10' 5-1/8"	5' 8-1/4"	47-3/4"	13' 11-3/4"

\* Tons at standard conditions: 96.3°F condensing, 20°F suction and 78°F W.B.

\*\* Gallons shown is water in suspension in unit and piping. Allow for additional water in bottom of remote sump to cover pump suction and strainer during operation. (12" would normally be sufficient.)

† Heaviest section is the coil section. **When 5.12g seismic design is required consult the factory for specific weights.**

\*\*\* Refrigerant charge is shown for R-717. Multiply by 1.93 for R-22 and 1.98 for R-134a.

Dimensions are subject to change. Do not use for pre-fabrication. Quantity of coil connections subject to change based on refrigerant and design conditions.

# Engineering Dimensions & Data

## Models ATC-642E to 967E

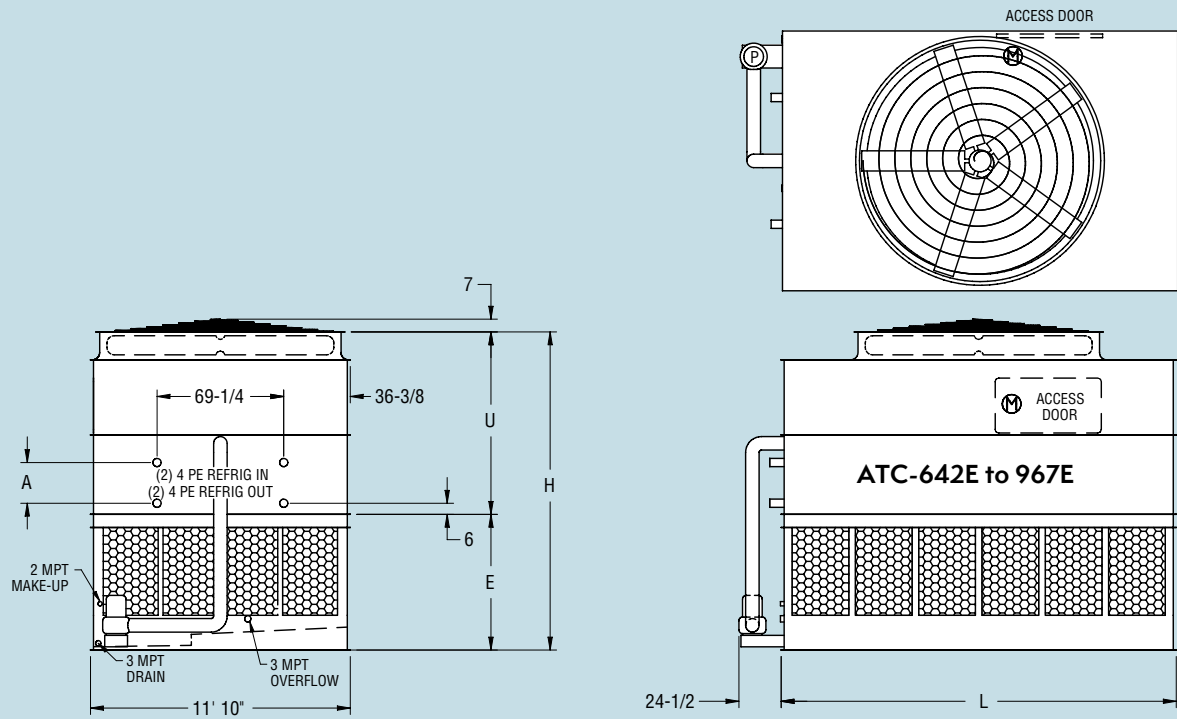

**Table 25 Engineering Data**

Model No.	R-717 Tons*	Fans		Weights†			Refrigerant Operating Charge lbs.***	Coil Volume ft <sup>3</sup>	Spray Pump		Remote Pump			Dimensions				
		HP	CFM	Shipping	Heaviest Section†	Operating			HP	GPM	Gallons Req'd**	Conn. Size	Operating Weight	Height H	Upper U	Lower E	Coil A	Length L
ATC-642E	456	20	110,100	23,690	19,770	33,930	597	81	7-1/2	1200	720	12"	28,060	15' 2-3/8"	9' 1/8"	6' 2-1/4"	30-3/4"	18' 0"
ATC-682E	484	25	118,400	23,720	19,800	33,960	597	81	7-1/2	1200	720	12"	28,090	15' 2-3/8"	9' 1/8"	6' 2-1/4"	30-3/4"	18' 0"
ATC-713E	506	30	126,000	23,770	19,850	34,010	597	81	7-1/2	1200	720	12"	28,140	15' 2-3/8"	9' 1/8"	6' 2-1/4"	30-3/4"	18' 0"
ATC-747E	531	25	114,900	27,020	23,100	37,540	741	101	7-1/2	1200	720	12"	31,670	15' 10-7/8"	9' 8-5/8"	6' 2-1/4"	39-1/4"	18' 0"
ATC-781E	554	30	122,100	27,070	23,150	37,590	741	101	7-1/2	1200	720	12"	31,720	15' 10-7/8"	9' 8-5/8"	6' 2-1/4"	39-1/4"	18' 0"
ATC-806E	572	30	118,400	30,460	26,540	41,260	885	121	7-1/2	1200	720	12"	35,390	16' 7-3/8"	10' 5-1/8"	6' 2-1/4"	47-3/4"	18' 0"
ATC-827E	587	40	132,600	27,230	23,310	37,750	741	101	7-1/2	1200	720	12"	31,880	15' 10-7/8"	9' 8-5/8"	6' 2-1/4"	39-1/4"	18' 0"
ATC-854E	606	40	128,400	30,620	26,700	41,420	885	121	7-1/2	1200	720	12"	35,550	16' 7-3/8"	10' 5-1/8"	6' 2-1/4"	47-3/4"	18' 0"
ATC-892E	633	50	136,700	30,630	26,710	41,430	885	121	7-1/2	1200	720	12"	35,560	16' 7-3/8"	10' 5-1/8"	6' 2-1/4"	47-3/4"	18' 0"
ATC-791E	562	40	147,600	26,350	21,840	37,840	662	90	10	1400	800	14"	31,140	15' 2-3/8"	9' 1/8"	6' 2-1/4"	30-3/4"	20' 0"
ATC-816E	580	30	131,100	29,870	25,360	41,660	822	112	10	1400	800	14"	34,960	15' 10-7/8"	9' 8-5/8"	6' 2-1/4"	39-1/4"	20' 0"
ATC-842E	598	30	126,900	34,020	29,510	46,120	983	134	10	1400	800	14"	39,420	16' 7-3/8"	10' 5-1/8"	6' 2-1/4"	47-3/4"	20' 0"
ATC-869E	617	40	143,200	30,030	25,520	41,820	822	112	10	1400	800	14"	35,120	15' 10-7/8"	9' 8-5/8"	6' 2-1/4"	39-1/4"	20' 0"
ATC-907E	644	50	152,400	30,040	25,530	41,830	822	112	10	1400	800	14"	35,130	15' 10-7/8"	9' 8-5/8"	6' 2-1/4"	39-1/4"	20' 0"
ATC-935E	664	50	147,600	34,190	29,680	46,290	983	134	10	1400	800	14"	39,590	16' 7-3/8"	10' 5-1/8"	6' 2-1/4"	47-3/4"	20' 0"
ATC-967E	687	60	155,300	34,390	29,880	46,490	983	134	10	1400	800	14"	39,790	16' 7-3/8"	10' 5-1/8"	6' 2-1/4"	47-3/4"	20' 0"

\* Tons at standard conditions: 96.3°F condensing, 20°F suction and 78°F W.B.  
 \*\* Gallons shown is water in suspension in unit and piping. Allow for additional water in bottom of remote sump to cover pump suction and strainer during operation. (12" would normally be sufficient.)  
 † Heaviest section is the coil section. **When 5.12g seismic design is required consult the factory for specific weights.**  
 \*\*\* Refrigerant charge is shown for R-717. Multiply by 1.93 for R-22 and 1.98 for R-134a.  
 Dimensions are subject to change. Do not use for pre-fabrication. Quantity of coil connections subject to change based on refrigerant and design conditions. Optional Dual Fan units will have a "-DF" at the end of the model number. Fan horsepower and weights may vary.

# Engineering Dimensions & Data

## Models ATC-840E to 1143E

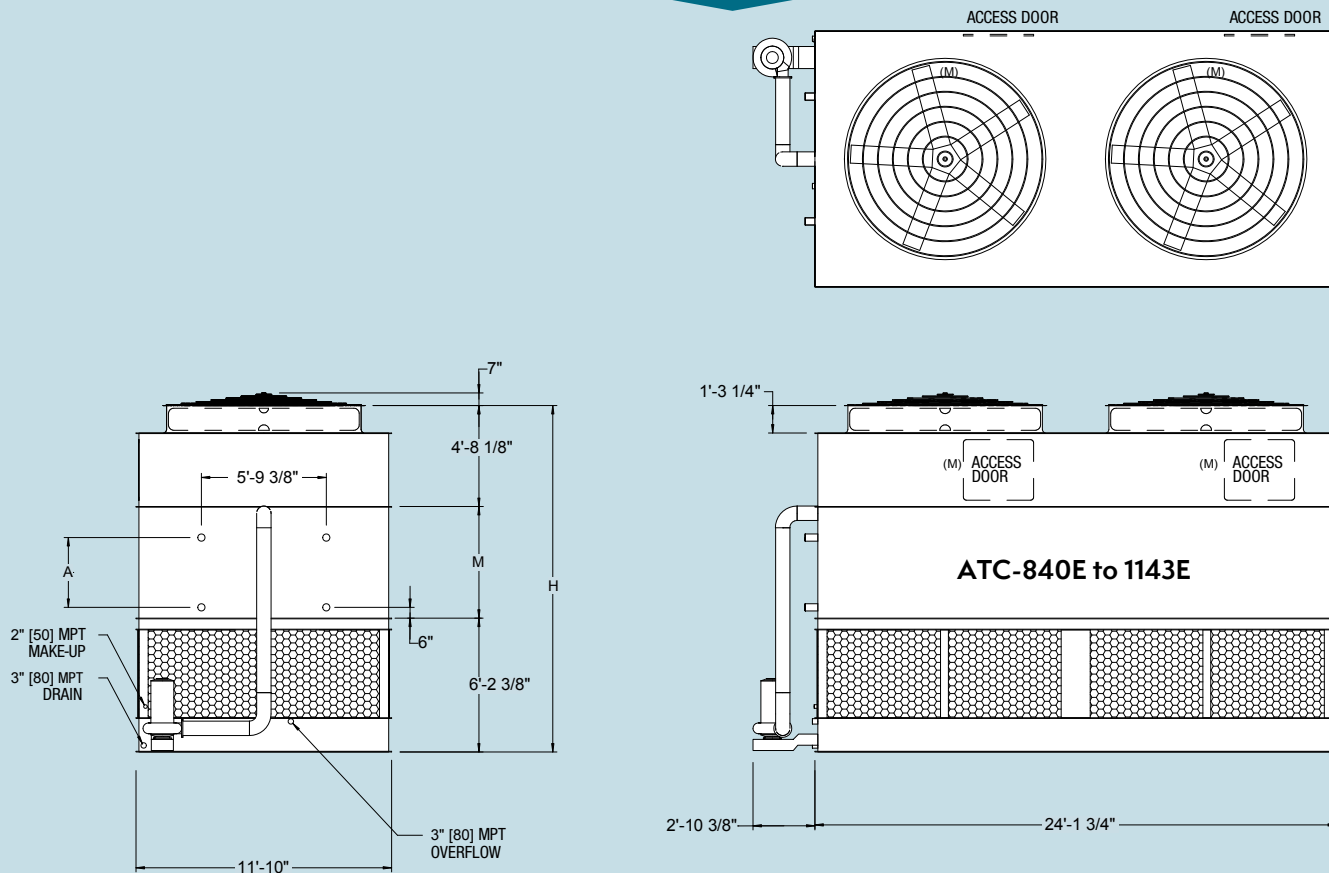

**Table 26 Engineering Data**

Model No.	R-717 Tons*	Weights†			Fans		Spray Pump		Refrigerant Operating Charge lbs.***	Coil Volume ft <sup>3</sup>	Remote Pump			Dimensions		
		Shipping	Heaviest Section†	Operating	HP	CFM	HP	GPM			Gallons Req'd**	Conn. Size	Operating Weight (lbs)	Height H	Middle M	Coil A
ATC-840E‡	596	33,690	22,625	46,820	(2) 15	140,700	10	1600	792	108	980	14"	38,760	16' 1/2"	5' 17/8"	38 3/4"
ATC-894E‡	635	33,810	22,625	46,940	(2) 20	154,900	10	1600	792	108	980	14"	38,880	16' 1/2"	5' 17/8"	38 3/4"
ATC-930E‡	660	33,870	22,625	47,000	(2) 25	165,100	10	1600	792	108	980	14"	38,940	16' 1/2"	5' 17/8"	38 3/4"
ATC-960E‡	681	42,840	31,775	56,350	(2) 15	132,300	10	1600	1178	161	980	14"	48,290	17' 8 1/2"	6' 9 7/8"	58 3/4"
ATC-986E‡	700	38,210	27,025	51,530	(2) 20	150,200	10	1600	985	134	980	14"	43,470	16' 10 1/2"	5' 11 7/8"	48 3/4"
ATC-1026E‡	728	38,270	27,025	51,590	(2) 25	160,100	10	1600	985	134	980	14"	43,530	16' 10 1/2"	5' 11 7/8"	48 3/4"
ATC-1056E‡	749	38,370	27,025	51,690	(2) 30	168,500	10	1600	985	134	980	14"	43,630	16' 10 1/2"	5' 11 7/8"	48 3/4"
ATC-1063E‡	754	43,020	31,775	56,530	(2) 25	155,200	10	1600	1178	161	980	14"	48,470	17' 8 1/2"	6' 9 7/8"	58 3/4"
ATC-1095E‡	777	43,120	31,775	56,630	(2) 30	163,300	10	1600	1178	161	980	14"	48,570	17' 8 1/2"	6' 9 7/8"	58 3/4"
ATC-1143E‡	811	43,440	31,775	56,950	(2) 40	177,000	10	1600	1178	161	980	14"	48,890	17' 8 1/2"	6' 9 7/8"	58 3/4"

\* Tons at standard conditions: 96.3°F condensing, 20°F suction and 78°F W.B.

\*\* Gallons shown is water in suspension in unit and piping. Allow for additional water in bottom of remote sump to cover pump suction and strainer during operation. (12" would normally be sufficient.)

† Heaviest section is the coil section. **When 5.12g seismic design is required consult the factory for specific weights.**

\*\*\* Refrigerant charge is shown for R-717. Multiply by 1.93 for R-22 and 1.98 for R-134a.

Dimensions are subject to change. Do not use for pre-fabrication. Quantity of coil connections subject to change based on refrigerant and design conditions.

‡ These units are available for ammonia applications only.

# Engineering Dimensions & Data

## Models ATC-858E to 1294E

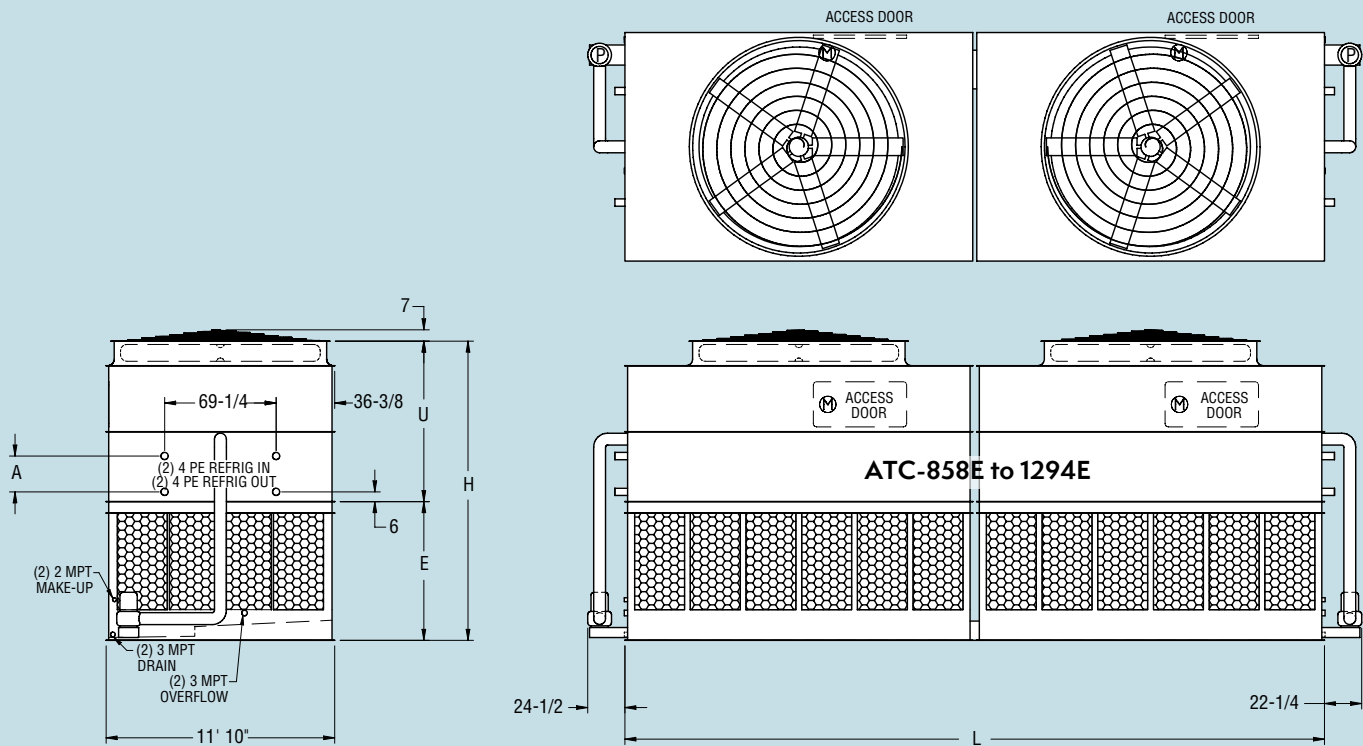

**Table 27 Engineering Data**

Model No.	R-717 Tons*	Fans		Weights†		Refrigerant Operating Charge lbs.***	Coil Volume ft <sup>3</sup>	Spray Pump		Remote Pump		Dimensions						
		HP	CFM	Shipping	Heaviest Section†			Operating	HP	GPM	Gallons Req'd**	Conn. Size	Operating Weight	Height H	Upper U	Lower E	Coil A	Length L
ATC-858E	608	(2)15	147,600	33,120	13,850	46,720	803	109	(2)5	1600	980	(2)12"	38,820	15' 2-3/8"	9' 1/8"	6' 2-1/4"	30-3/4"	24' 2"
ATC-913E	648	(2)20	162,500	33,240	13,910	46,840	803	109	(2)5	1600	980	(2)12"	38,940	15' 2-3/8"	9' 1/8"	6' 2-1/4"	30-3/4"	24' 2"
ATC-949E	674	(2)25	173,200	33,300	13,940	46,900	803	109	(2)5	1600	980	(2)12"	39,000	15' 2-3/8"	9' 1/8"	6' 2-1/4"	30-3/4"	24' 2"
ATC-980E	695	(2)15	138,900	42,200	18,390	56,520	1185	161	(2)5	1600	980	(2)12"	48,620	16' 7-3/8"	10' 5-1/8"	6' 2-1/4"	47-3/4"	24' 2"
ATC-1007E	714	(2)20	157,800	37,600	16,090	51,560	994	135	(2)5	1600	980	(2)12"	43,660	15' 10-7/8"	9' 8-5/8"	6' 2-1/4"	39-1/4"	24' 2"
ATC-1047E	743	(2)25	168,000	37,660	16,120	51,620	994	135	(2)5	1600	980	(2)12"	43,720	15' 10-7/8"	9' 8-5/8"	6' 2-1/4"	39-1/4"	24' 2"
ATC-1078E	765	(2)30	177,000	37,760	16,170	51,720	994	135	(2)5	1600	980	(2)12"	43,820	15' 10-7/8"	9' 8-5/8"	6' 2-1/4"	39-1/4"	24' 2"
ATC-1085E	770	(2)25	162,700	42,380	18,480	56,700	1185	161	(2)5	1600	980	(2)12"	48,800	16' 7-3/8"	10' 5-1/8"	6' 2-1/4"	47-3/4"	24' 2"
ATC-1118E	793	(2)30	171,500	42,480	18,530	56,800	1185	161	(2)5	1600	980	(2)12"	48,900	16' 7-3/8"	10' 5-1/8"	6' 2-1/4"	47-3/4"	24' 2"
ATC-1167E	828	(2)40	185,700	42,800	18,690	57,120	1185	161	(2)5	1600	980	(2)12"	49,220	16' 7-3/8"	10' 5-1/8"	6' 2-1/4"	47-3/4"	24' 2"
ATC-1164E	826	(2)25	187,900	42,780	18,330	59,220	1157	158	(2)5	1800	1140	(2)12"	50,080	16' 10-7/8"	9' 8-5/8"	7' 2-1/4"	39-1/4"	28' 2"
ATC-1204E	854	(2)25	182,100	48,780	21,330	65,640	1380	188	(2)5	1800	1140	(2)12"	56,500	17' 7-3/8"	10' 5-1/8"	7' 2-1/4"	47-3/4"	28' 2"
ATC-1240E	880	(2)30	191,600	48,880	21,380	65,740	1380	188	(2)5	1800	1140	(2)12"	56,600	17' 7-3/8"	10' 5-1/8"	7' 2-1/4"	47-3/4"	28' 2"
ATC-1294E	918	(2)40	207,600	49,200	21,540	66,060	1380	188	(2)5	1800	1140	(2)12"	56,920	17' 7-3/8"	10' 5-1/8"	7' 2-1/4"	47-3/4"	28' 2"

\* Tons at standard conditions: 96.3°F condensing, 20°F suction and 78°F W.B.

\*\* Gallons shown is water in suspension in unit and piping. Allow for additional water in bottom of remote sump to cover pump suction and strainer during operation. (12" would normally be sufficient.)

† Heaviest section is the coil section. **When 5.12g seismic design is required consult the factory for specific weights.**

\*\*\* Refrigerant charge is shown for R-717. Multiply by 1.93 for R-22 and 1.98 for R-134a.

Dimensions are subject to change. Do not use for pre-fabrication. Quantity of coil connections subject to change based on refrigerant and design conditions.



# Engineering Dimensions & Data

## Models ATC-1192E to 1925E

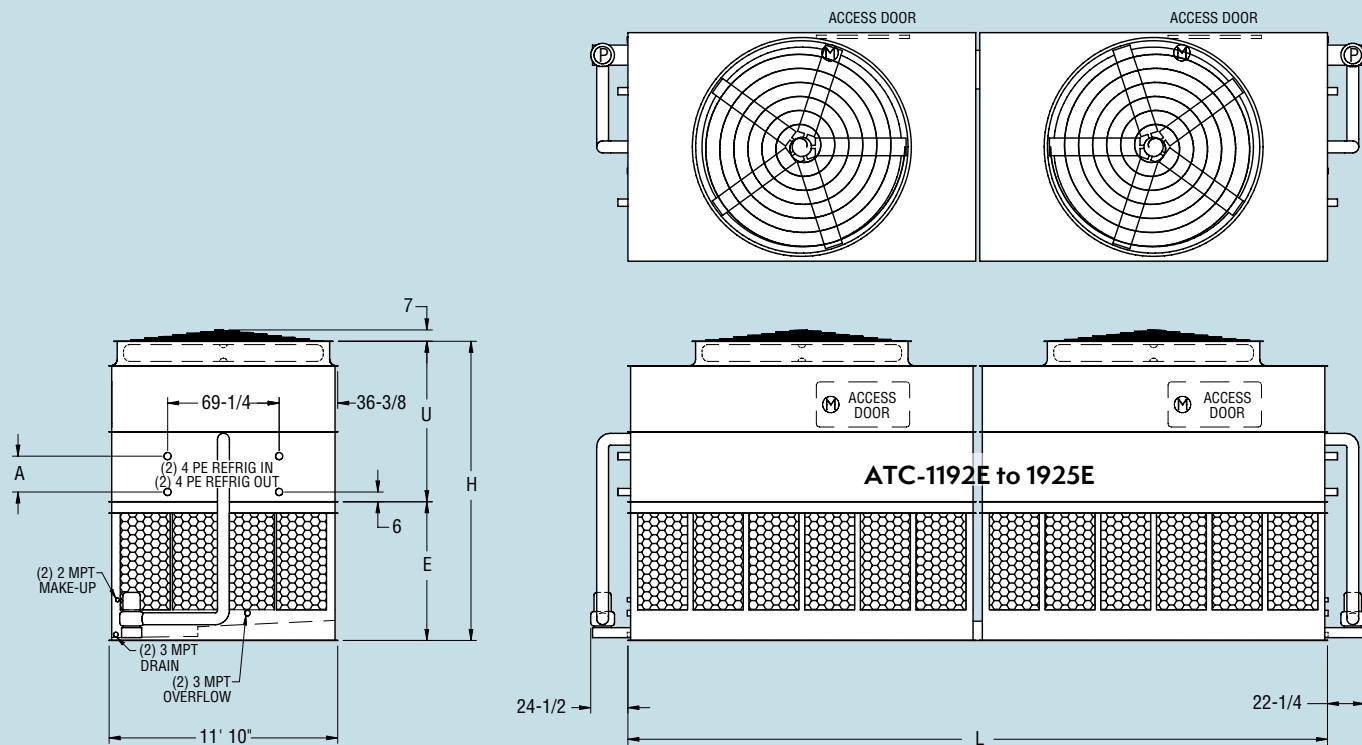

**Table 28 Engineering Data**

Model No.	R-717 Tons*	Fans		Weights†			Refrigerant Operating Charge lbs.**	Coil Volume ft <sup>3</sup>	Spray Pump		Remote Pump		Dimensions					
		HP	CFM	Shipping	Heaviest Section†	Operating			HP	GPM	Gallons Req'd**	Conn. Size	Operating Weight	Height H	Upper U	Lower E	Coil A	Length L
ATC-1192E	845	[2]30	259,500	40,680	16,420	60,600	904	123	[2]7.5	2400	1440	[2]12"	48,860	15' 5-7/8"	8' 3-5/8"	7' 2-1/4"	22-1/4"	36' 2-1/2"
ATC-1284E	911	[2]20	220,100	47,380	19,770	67,860	1193	163	[2]7.5	2400	1440	[2]12"	56,120	16' 2-3/8"	9' 1/8"	7' 2-1/4"	30-3/4"	36' 2-1/2"
ATC-1365E	969	[2]25	236,700	47,440	19,800	67,920	1193	163	[2]7.5	2400	1440	[2]12"	56,180	16' 2-3/8"	9' 1/8"	7' 2-1/4"	30-3/4"	36' 2-1/2"
ATC-1426E	1012	[2]30	252,000	47,540	19,850	68,020	1193	163	[2]7.5	2400	1440	[2]12"	56,280	16' 2-3/8"	9' 1/8"	7' 2-1/4"	30-3/4"	36' 2-1/2"
ATC-1496E	1061	[2]25	229,800	54,040	23,100	75,080	1482	202	[2]7.5	2400	1440	[2]12"	63,340	16' 10-7/8"	9' 8-5/8"	7' 2-1/4"	39-1/4"	36' 2-1/2"
ATC-1562E	1109	[2]30	244,200	54,140	23,150	75,180	1482	202	[2]7.5	2400	1440	[2]12"	63,440	16' 10-7/8"	9' 8-5/8"	7' 2-1/4"	39-1/4"	36' 2-1/2"
ATC-1655E	1175	[2]40	265,100	54,460	23,310	75,500	1482	202	[2]7.5	2400	1440	[2]12"	63,760	16' 10-7/8"	9' 8-5/8"	7' 2-1/4"	39-1/4"	36' 2-1/2"
ATC-1709E	1213	[2]40	256,800	61,240	26,700	82,840	1771	241	[2]7.5	2400	1440	[2]12"	71,100	17' 7-3/8"	10' 5-1/8"	7' 2-1/4"	47-3/4"	36' 2-1/2"
ATC-1784E	1266	[2]50	273,400	61,260	26,710	82,860	1771	241	[2]7.5	2400	1440	[2]12"	71,120	17' 7-3/8"	10' 5-1/8"	7' 2-1/4"	47-3/4"	36' 2-1/2"
ATC-1625E	1153	[2]30	262,100	59,740	25,360	83,320	1645	224	[2]10	2800	1600	[2]14"	69,920	16' 10-7/8"	9' 8-5/8"	7' 2-1/4"	39-1/4"	40' 2-1/2"
ATC-1729E	1227	[2]40	286,400	60,060	25,520	83,640	1645	224	[2]10	2800	1600	[2]14"	70,240	16' 10-7/8"	9' 8-5/8"	7' 2-1/4"	39-1/4"	40' 2-1/2"
ATC-1805E	1281	[2]50	304,800	60,080	25,530	83,660	1645	224	[2]10	2800	1600	[2]14"	70,260	16' 10-7/8"	9' 8-5/8"	7' 2-1/4"	39-1/4"	40' 2-1/2"
ATC-1861E	1321	[2]50	295,100	68,380	29,680	92,580	1966	268	[2]10	2800	1600	[2]14"	79,180	17' 7-3/8"	10' 5-1/8"	7' 2-1/4"	47-3/4"	40' 2-1/2"
ATC-1925E	1367	[2]60	310,600	68,780	29,880	92,980	1966	268	[2]10	2800	1600	[2]14"	79,580	17' 7-3/8"	10' 5-1/8"	7' 2-1/4"	47-3/4"	40' 2-1/2"

\* Tons at standard conditions: 96.3°F condensing, 20°F suction and 78°F W.B.

\*\* Gallons shown is water in suspension in unit and piping. Allow for additional water in bottom of remote sump to cover pump suction and strainer during operation. (12" would normally be sufficient.)

† Heaviest section is the coil section. **When 5.12g seismic design is required consult the factory for specific weights.**

\*\*\* Refrigerant charge is shown for R-717. Multiply by 1.93 for R-22 and 1.98 for R-134a.

Dimensions are subject to change. Do not use for pre-fabrication. Quantity of coil connections subject to change based on refrigerant and design conditions.

Optional Dual Fan units will have a "-DF" at the end of the model number. Fan horsepower and weights may vary.

# Engineering Dimensions & Data

## Models ATC-857E to 1293E

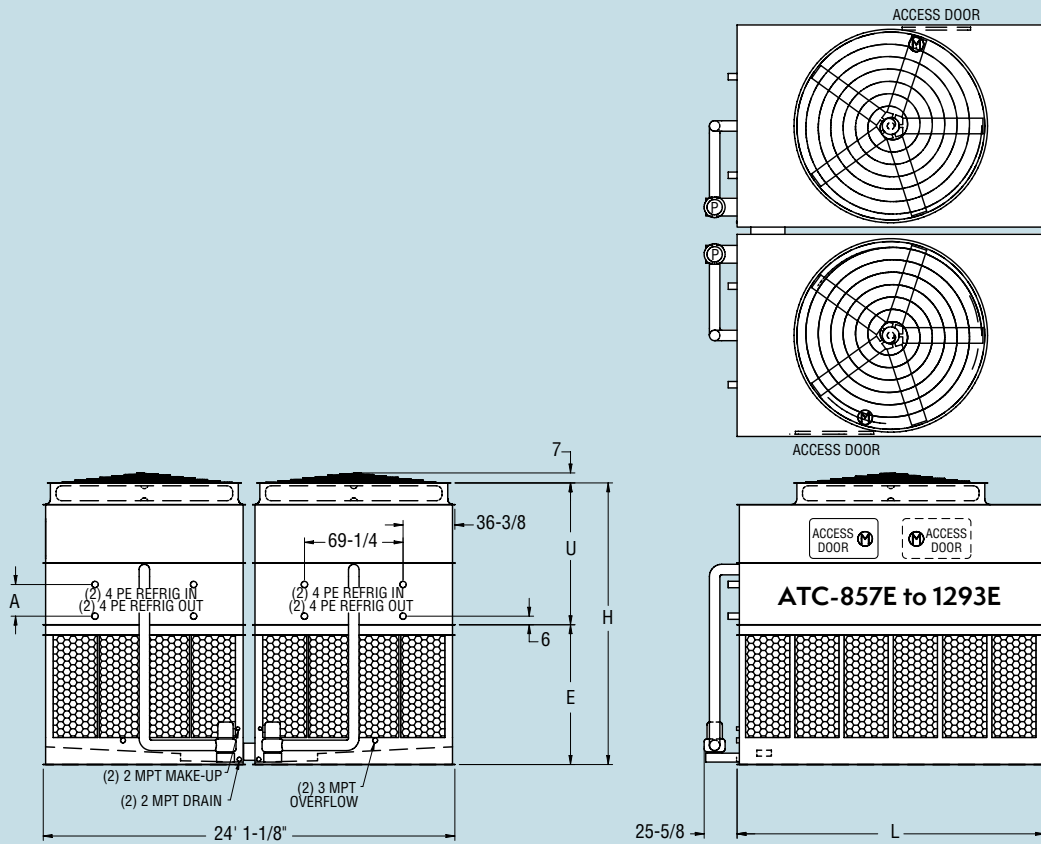

**Table 30 Engineering Data**

Model No.	R-717 Tons*	Fans		Weights†		Refrigerant Operating Charge lbs.**	Coil Volume ft <sup>3</sup>	Spray Pump		Remote Pump			Dimensions					
		HP	CFM	Shipping	Heaviest Section†			Operating	HP	GPM	Gallons Req'd**	Conn. Size	Operating Weight	Height H	Upper U	Lower E	Coil A	Length L
ATC-857E	608	(2)15	147,600	33,120	13,850	46,720	803	109	(2)5	1600	980	(2)12"	38,820	15' 2-3/8"	9' 1/8"	6' 2-1/4"	30-3/4"	11' 11-3/4"
ATC-912E	648	(2)20	162,500	33,240	13,910	46,840	803	109	(2)5	1600	980	(2)12"	38,940	15' 2-3/8"	9' 1/8"	6' 2-1/4"	30-3/4"	11' 11-3/4"
ATC-979E	695	(2)15	138,900	42,200	18,390	56,520	1185	161	(2)5	1600	980	(2)12"	48,620	16' 7-3/8"	10' 5-1/8"	6' 2-1/4"	47-3/4"	11' 11-3/4"
ATC-1006E	714	(2)20	157,800	37,600	16,090	51,560	994	135	(2)5	1600	980	(2)12"	43,660	15' 10-7/8"	9' 8-5/8"	6' 2-1/4"	39-1/4"	11' 11-3/4"
ATC-1046E	743	(2)25	168,000	37,660	16,120	51,620	994	135	(2)5	1600	980	(2)12"	43,720	15' 10-7/8"	9' 8-5/8"	6' 2-1/4"	39-1/4"	11' 11-3/4"
ATC-1077E	765	(2)30	177,000	37,760	16,170	51,720	994	135	(2)5	1600	980	(2)12"	43,820	15' 10-7/8"	9' 8-5/8"	6' 2-1/4"	39-1/4"	11' 11-3/4"
ATC-1117E	793	(2)30	171,500	42,480	18,530	56,800	1185	161	(2)5	1600	980	(2)12"	48,900	16' 7-3/8"	10' 5-1/8"	6' 2-1/4"	47-3/4"	11' 11-3/4"
ATC-1166E	828	(2)40	185,700	42,800	18,690	57,120	1185	161	(2)5	1600	980	(2)12"	49,220	16' 7-3/8"	10' 5-1/8"	6' 2-1/4"	47-3/4"	11' 11-3/4"
ATC-1163E	826	(2)25	187,900	42,780	18,330	59,220	1157	158	(2)5	1800	1140	(2)12"	50,080	16' 10-7/8"	9' 8-5/8"	7' 2-1/4"	39-1/4"	13' 11-3/4"
ATC-1203E	854	(2)25	182,100	48,780	21,330	65,640	1380	188	(2)5	1800	1140	(2)12"	56,500	17' 7-3/8"	10' 5-1/8"	7' 2-1/4"	47-3/4"	13' 11-3/4"
ATC-1239E	880	(2)30	191,600	48,880	21,380	65,740	1380	188	(2)5	1800	1140	(2)12"	56,600	17' 7-3/8"	10' 5-1/8"	7' 2-1/4"	47-3/4"	13' 11-3/4"
ATC-1293E	918	(2)40	207,600	49,200	21,540	66,060	1380	188	(2)5	1800	1140	(2)12"	56,920	17' 7-3/8"	10' 5-1/8"	7' 2-1/4"	47-3/4"	13' 11-3/4"

\* Tons at standard conditions: 96.3°F condensing, 20°F suction and 78°F W.B.

\*\* Gallons shown is water in suspension in unit and piping. Allow for additional water in bottom of remote sump to cover pump suction and strainer during operation. (12" would normally be sufficient.)

† Heaviest section is the coil section. **When 5.12g seismic design is required consult the factory for specific weights.**

\*\*\* Refrigerant charge is shown for R-717. Multiply by 1.93 for R-22 and 1.98 for R-134a.

Dimensions are subject to change. Do not use for pre-fabrication. Quantity of coil connections subject to change based on refrigerant and design conditions.

# Engineering Dimensions & Data

## Models ATC-1191E to 1915E

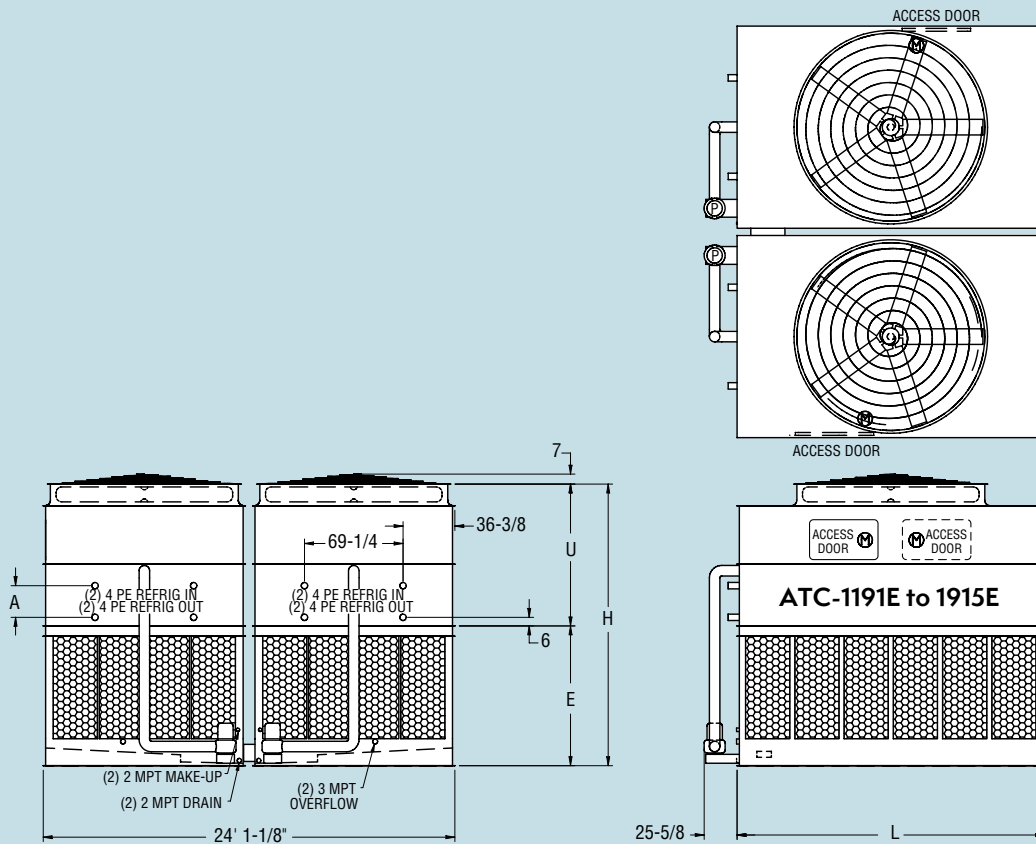

**Table 31 Engineering Data**

Model No.	R-717 Tons*	Fans		Weights†			Refrigerant Operating Charge lbs.**	Coil Volume ft <sup>3</sup>	Spray Pump		Remote Pump			Dimensions				
		HP	CFM	Shipping	Heaviest Section†	Operating			HP	GPM	Gallons Req'd**	Conn. Size	Operating Weight	Height H	Upper U	Lower E	Coil A	Length L
ATC-1191E	845	[2]30	259,500	40,680	16,420	60,600	904	123	[2]7.5	2400	1440	[2]12"	48,860	16' 5-7/8"	8' 3-5/8"	8' 2-1/4"	22-1/4"	18' 0"
ATC-1283E	911	[2]20	220,100	47,380	19,770	67,860	1193	163	[2]7.5	2400	1440	[2]12"	56,120	17' 2-3/8"	9' 1/8"	8' 2-1/4"	30-3/4"	18' 0"
ATC-1364E	969	[2]25	236,700	47,440	19,800	67,920	1193	163	[2]7.5	2400	1440	[2]12"	56,180	17' 2-3/8"	9' 1/8"	8' 2-1/4"	30-3/4"	18' 0"
ATC-1425E	1012	[2]30	252,000	47,540	19,850	68,020	1193	163	[2]7.5	2400	1440	[2]12"	56,280	17' 2-3/8"	9' 1/8"	8' 2-1/4"	30-3/4"	18' 0"
ATC-1495E	1061	[2]25	229,800	54,040	23,100	75,080	1482	202	[2]7.5	2400	1440	[2]12"	63,340	17' 10-7/8"	9' 8-5/8"	8' 2-1/4"	39-1/4"	18' 0"
ATC-1561E	1109	[2]30	244,200	54,140	23,150	75,180	1482	202	[2]7.5	2400	1440	[2]12"	63,440	17' 10-7/8"	9' 8-5/8"	8' 2-1/4"	39-1/4"	18' 0"
ATC-1654E	1175	[2]40	265,100	54,460	23,310	75,500	1482	202	[2]7.5	2400	1440	[2]12"	63,760	17' 10-7/8"	9' 8-5/8"	8' 2-1/4"	39-1/4"	18' 0"
ATC-1708E	1213	[2]40	256,800	61,240	26,700	82,840	1771	241	[2]7.5	2400	1440	[2]12"	71,100	18' 7-3/8"	10' 5-1/8"	8' 2-1/4"	47-3/4"	18' 0"
ATC-1783E	1266	[2]50	273,400	61,260	26,710	82,860	1771	241	[2]7.5	2400	1440	[2]12"	71,120	18' 7-3/8"	10' 5-1/8"	8' 2-1/4"	47-3/4"	18' 0"
ATC-1616E	1148	[2]30	260,800	59,740	25,360	83,320	1645	224	[2]10	2800	1600	[2]14"	69,920	17' 10-7/8"	9' 8-5/8"	8' 2-1/4"	39-1/4"	20' 0"
ATC-1720E	1221	[2]40	284,900	60,060	25,520	83,640	1645	224	[2]10	2800	1600	[2]14"	70,240	17' 10-7/8"	9' 8-5/8"	8' 2-1/4"	39-1/4"	20' 0"
ATC-1795E	1275	[2]50	303,300	60,080	25,530	83,660	1645	224	[2]10	2800	1600	[2]14"	70,260	17' 10-7/8"	9' 8-5/8"	8' 2-1/4"	39-1/4"	20' 0"
ATC-1851E	1315	[2]50	293,600	68,380	29,680	92,580	1966	268	[2]10	2800	1600	[2]14"	79,180	18' 7-3/8"	10' 5-1/8"	8' 2-1/4"	47-3/4"	20' 0"
ATC-1915E	1360	[2]60	309,100	68,780	29,880	92,980	1966	268	[2]10	2800	1600	[2]14"	79,580	18' 7-3/8"	10' 5-1/8"	8' 2-1/4"	47-3/4"	20' 0"

\* Tons at standard conditions: 96.3°F condensing, 20°F suction and 78°F W.B.

\*\* Gallons shown is water in suspension in unit and piping. Allow for additional water in bottom of remote sump to cover pump suction and strainer during operation. (12" would normally be sufficient.)

† Heaviest section is the coil section. **When 5.12g seismic design is required consult the factory for specific weights.**

\*\*\* Refrigerant charge is shown for R-717. Multiply by 1.93 for R-22 and 1.98 for R-134a.

Dimensions are subject to change. Do not use for pre-fabrication. Quantity of coil connections subject to change based on refrigerant and design conditions. Optional Dual Fan units will have a "-DF" at the end of the model number. Fan horsepower and weights may vary.

# Engineering Dimensions & Data

## Models ATC-1841E to 2273E

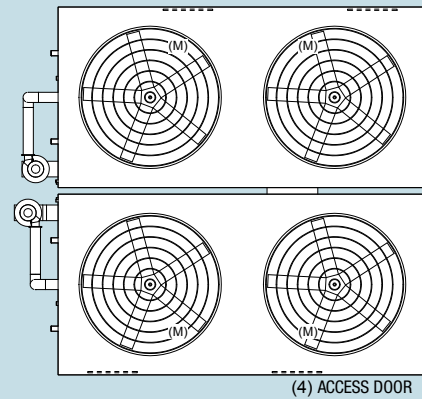

(4) ACCESS DOOR

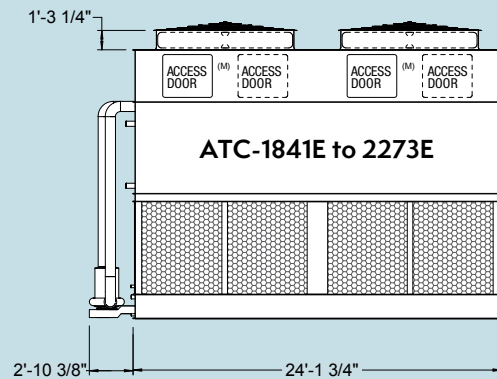
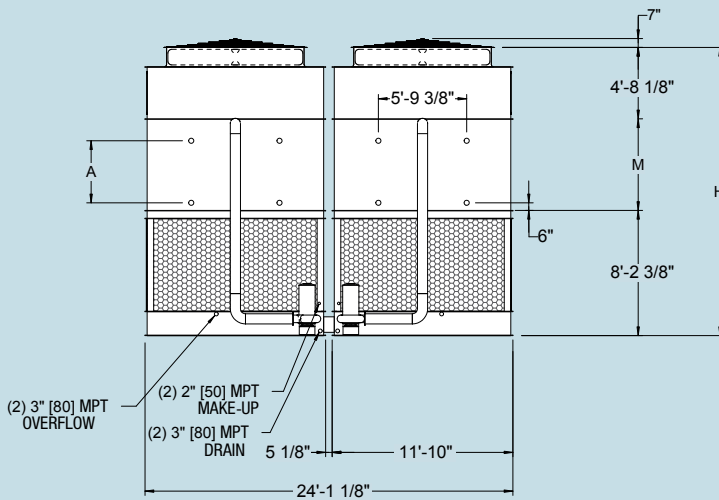

**Table 29 Engineering Data**

Model No.	R-717 Tons <sup>*</sup>	Weights <sup>†</sup>			Fans		Spray Pump		Refrigerant Operating Charge lbs. <sup>***</sup>	Coil Volume ft <sup>3</sup>	Remote Pump			Dimensions		
		Shipping	Heaviest Section <sup>†</sup>	Operating	HP	CFM	HP	GPM			Gallons Req'd <sup>**</sup>	Conn. Size	Operating Weight (lbs)	Height H	Middle M	Coil A
ATC-1841E <sup>‡</sup>	1306	76,580	27,025	103,220	(4) 15	273,000	(2) 10	3200	1970	268	1960	14"	87,100	18' 10 1/2"	5' 11 7/8"	48 3/4"
ATC-1961E <sup>‡</sup>	1391	76,820	27,025	103,460	(4) 20	300,500	(2) 10	3200	1970	268	1960	14"	87,340	18' 10 1/2"	5' 11 7/8"	48 3/4"
ATC-1961E <sup>‡</sup>	1447	76,940	27,025	103,580	(4) 25	320,300	(2) 10	3200	1970	268	1960	14"	87,460	18' 10 1/2"	5' 11 7/8"	48 3/4"
ATC-1961E <sup>‡</sup>	1500	86,440	31,775	113,460	(4) 25	310,400	(2) 10	3200	2356	321	1960	14"	97,340	19' 8 1/2"	6' 9 7/8"	58 3/4"
ATC-1961E <sup>‡</sup>	1545	86,640	31,775	113,660	(4) 30	326,600	(2) 10	3200	2356	321	1960	14"	97,540	19' 8 1/2"	6' 9 7/8"	58 3/4"
ATC-1961E <sup>‡</sup>	1613	87,280	31,775	114,300	(4) 40	354,100	(2) 10	3200	2356	321	1960	14"	98,180	19' 8 1/2"	6' 9 7/8"	58 3/4"

\* Tons at standard conditions: 96.3°F condensing, 20°F suction and 78°F W.B.

\*\* Gallons shown is water in suspension in unit and piping. Allow for additional water in bottom of remote sump to cover pump suction and strainer during operation. (12" would normally be sufficient.)

† Heaviest section is the coil section. **When 5.12g seismic design is required consult the factory for specific weights.**

\*\*\* Refrigerant charge is shown for R-717. Multiply by 1.93 for R-22 and 1.98 for R-134a.

Dimensions are subject to change. Do not use for pre-fabrication. Quantity of coil connections subject to change based on refrigerant and design conditions.

‡ These units are available for ammonia applications only.

# Engineering Dimensions & Data

## Models ATC-1879E to 3714E

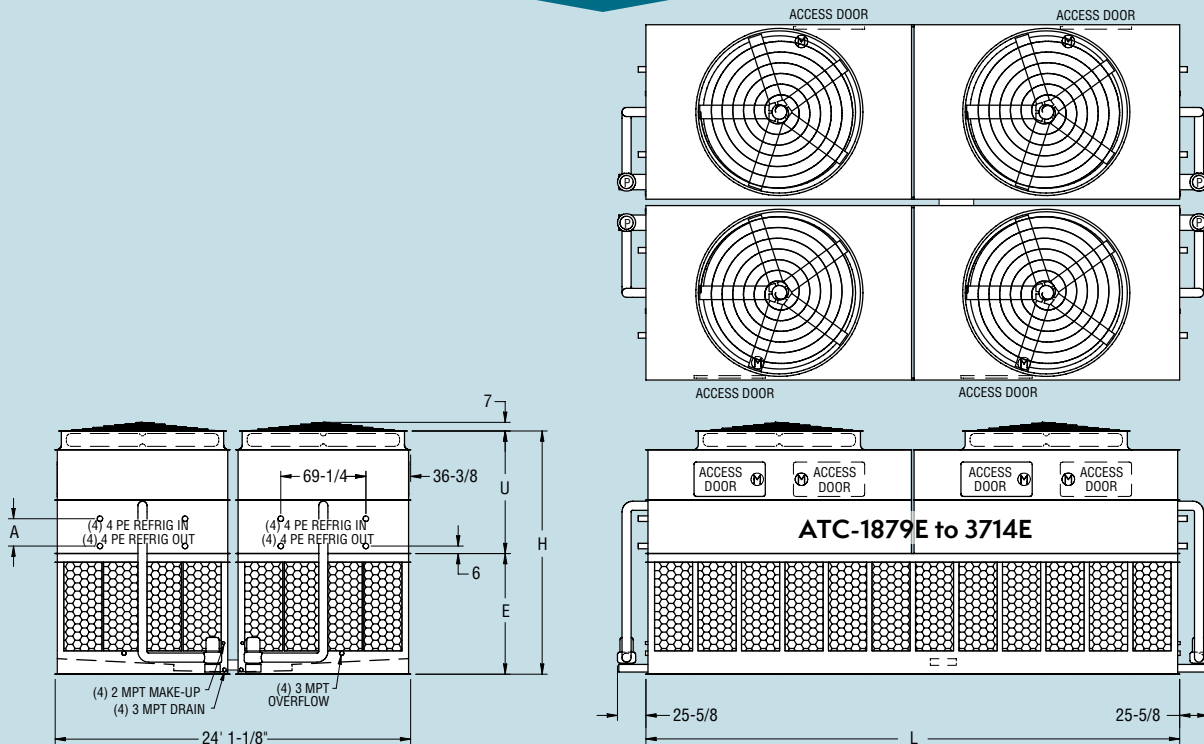

**Table 32 Engineering Data**

Model No.	R-717 Tons*	Fans		Weights†			Refrigerant Operating Charge lbs.**	Coil Volume ft <sup>3</sup>	Spray Pump		Remote Pump			Dimensions				
		HP	CFM	Shipping	Heaviest Section†	Operating			HP	GPM	Gallons Req'd**	Conn. Size	Operating Weight	Height H	Upper U	Lower E	Coil A	Length L
ATC-1879E	1334	(4)15	286,600	75,300	16,030	103,240	1988	271	(4)5	3200	1960	(4)12"	87,180	17' 10-7/8"	9' 8-5/8"	8' 2-1/4"	39-1/4"	24' 2"
ATC-2002E	1421	(4)20	315,600	75,540	16,090	103,480	1988	271	(4)5	3200	1960	(4)12"	87,420	17' 10-7/8"	9' 8-5/8"	8' 2-1/4"	39-1/4"	24' 2"
ATC-2082E	1478	(4)25	336,000	75,660	16,120	103,600	1988	271	(4)5	3200	1960	(4)12"	87,540	17' 10-7/8"	9' 8-5/8"	8' 2-1/4"	39-1/4"	24' 2"
ATC-2158E	1532	(4)25	325,500	85,100	18,480	113,760	2370	323	(4)5	3200	1960	(4)12"	97,700	18' 7-3/8"	10' 5-1/8"	8' 2-1/4"	47-3/4"	24' 2"
ATC-2223E	1578	(4)30	342,900	85,300	18,530	113,960	2370	323	(4)5	3200	1960	(4)12"	97,900	18' 7-3/8"	10' 5-1/8"	8' 2-1/4"	47-3/4"	24' 2"
ATC-2320E	1647	(4)40	371,400	85,940	18,690	114,600	2370	323	(4)5	3200	1960	(4)12"	98,540	18' 7-3/8"	10' 5-1/8"	8' 2-1/4"	47-3/4"	24' 2"
ATC-2256E	1602	(4)25	370,200	85,760	18,330	118,780	2313	315	(4)5	3600	2280	(4)12"	100,220	17' 10-7/8"	9' 8-5/8"	8' 2-1/4"	39-1/4"	28' 2"
ATC-2324E	1650	(4)30	389,500	85,960	18,380	118,980	2313	315	(4)5	3600	2280	(4)12"	100,420	17' 10-7/8"	9' 8-5/8"	8' 2-1/4"	39-1/4"	28' 2"
ATC-2404E	1707	(4)30	377,500	97,960	21,380	131,820	2761	376	(4)5	3600	2280	(4)12"	113,260	18' 7-3/8"	10' 5-1/8"	8' 2-1/4"	47-3/4"	28' 2"
ATC-2509E	1781	(4)40	408,900	98,600	21,540	132,460	2761	376	(4)5	3600	2280	(4)12"	113,900	18' 7-3/8"	10' 5-1/8"	8' 2-1/4"	47-3/4"	28' 2"
ATC-2490E	1768	(4)20	433,700	95,360	19,770	136,520	2386	325	(4)7.5	4800	2880	(4)12"	112,740	17' 2-3/8"	9' 1/8"	8' 2-1/4"	30-3/4"	36' 2-1/2"
ATC-2647E	1879	(4)25	466,400	95,480	19,800	136,640	2386	325	(4)7.5	4800	2880	(4)12"	112,860	17' 2-3/8"	9' 1/8"	8' 2-1/4"	30-3/4"	36' 2-1/2"
ATC-2765E	1963	(4)30	496,500	95,680	19,850	136,840	2386	325	(4)7.5	4800	2880	(4)12"	113,060	17' 2-3/8"	9' 1/8"	8' 2-1/4"	30-3/4"	36' 2-1/2"
ATC-2900E	2059	(4)25	452,600	108,680	23,100	150,960	2964	404	(4)7.5	4800	2880	(4)12"	127,180	17' 10-7/8"	9' 8-5/8"	8' 2-1/4"	39-1/4"	36' 2-1/2"
ATC-3029E	2151	(4)30	481,000	108,880	23,150	151,160	2964	404	(4)7.5	4800	2880	(4)12"	127,380	17' 10-7/8"	9' 8-5/8"	8' 2-1/4"	39-1/4"	36' 2-1/2"
ATC-3210E	2279	(4)40	522,300	109,520	23,310	151,800	2964	404	(4)7.5	4800	2880	(4)12"	128,020	17' 10-7/8"	9' 8-5/8"	8' 2-1/4"	39-1/4"	36' 2-1/2"
ATC-3313E	2352	(4)40	506,000	123,080	26,700	166,480	3542	483	(4)7.5	4800	2880	(4)12"	142,700	18' 7-3/8"	10' 5-1/8"	8' 2-1/4"	47-3/4"	36' 2-1/2"
ATC-3459E	2456	(4)50	538,700	123,120	26,710	166,520	3542	483	(4)7.5	4800	2880	(4)12"	142,740	18' 7-3/8"	10' 5-1/8"	8' 2-1/4"	47-3/4"	36' 2-1/2"
ATC-2855E	2027	(4)30	529,900	104,860	21,680	151,000	2647	361	(4)10	5600	3200	(4)14"	123,900	17' 2-3/8"	9' 1/8"	8' 2-1/4"	30-3/4"	40' 2-1/2"
ATC-3232E	2295	(4)30	497,500	136,180	29,510	184,760	3932	536	(4)10	5600	3200	(4)14"	157,660	18' 7-3/8"	10' 5-1/8"	8' 2-1/4"	47-3/4"	40' 2-1/2"
ATC-3336E	2368	(4)40	561,300	120,220	25,520	167,560	3290	448	(4)10	5600	3200	(4)14"	140,460	17' 10-7/8"	9' 8-5/8"	8' 2-1/4"	39-1/4"	40' 2-1/2"
ATC-3482E	2472	(4)50	597,400	120,260	25,530	167,600	3290	448	(4)10	5600	3200	(4)14"	140,500	17' 10-7/8"	9' 8-5/8"	8' 2-1/4"	39-1/4"	40' 2-1/2"
ATC-3591E	2549	(4)50	578,400	136,860	29,680	185,440	3932	536	(4)10	5600	3200	(4)14"	158,340	18' 7-3/8"	10' 5-1/8"	8' 2-1/4"	47-3/4"	40' 2-1/2"
ATC-3714E	2637	(4)60	608,900	137,660	29,880	186,240	3932	536	(4)10	5600	3200	(4)14"	159,140	18' 7-3/8"	10' 5-1/8"	8' 2-1/4"	47-3/4"	40' 2-1/2"

\* Tons at standard conditions: 96.3°F condensing, 20°F suction and 78°F W.B.

\*\* Gallons shown is water in suspension in unit and piping. Allow for additional water in bottom of remote sump to cover pump suction and strainer during operation. (12" would normally be sufficient.)

† Heaviest section is the coil section. **When 5.12g seismic design is required consult the factory for specific weights.**

\*\*\* Refrigerant charge is shown for R-717. Multiply by 1.93 for R-22 and 1.98 for R-134a.

Dimensions are subject to change. Do not use for pre-fabrication. Quantity of coil connections subject to change based on refrigerant and design conditions. Optional Dual Fan units will have a "-DF" at the end of the model number. Fan horsepower and weights may vary.

# ATC-E Steel Support/Optional Equipment

EVAPCO ATC-E condensers are designed to be supported with structural "I" beams located under the outer flanges and running the entire length of the unit. Mounting holes, 3/4" in diameter, are located in the bottom channels of the pan section to provide for bolting to the structural steel. (Refer to certified drawings from the factory for bolt hole locations.) Beams should be level to within 1/8" in 6' before setting the unit in place. Do not level the unit by shimming between it and the "I" beams as this will not provide proper longitudinal support.

**NOTE: Consult the latest edition of IBC for required steel support layout and structural design.**

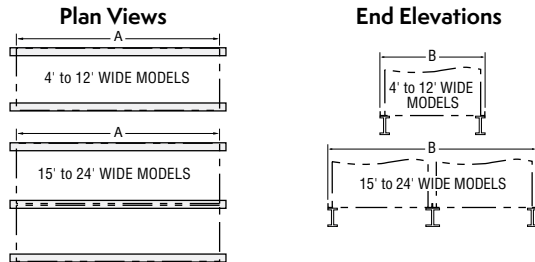

Steel Dimensions		
	A	B
<b>4' Wide Models</b>		
ATC-50E to 165E	5' 11-7/8"	4' 1/4"
90E to 120E	8' 11-1/2"	4' 1/4"
135E to 165E	11' 11-3/4"	4' 1/4"
<b>7' 4" Wide Models</b>		
ATC-181E to 261E	8' 11-1/2"	7' 4"
264E to 351E	11' 11-3/4"	7' 4"
268E to 411E	13' 11-3/4"	7' 4"
362E to 522E	18'	7' 4"
528E to 702E	24' 2"	7' 4"
536E to 822E	28' 2"	7' 4"
724E to 1044E	36' 2-1/2"	7' 4"
361E to 521E	8' 11-1/2"	15' 1-1/8"
526E to 701E	11' 11-3/4"	15' 1-1/8"
535E to 821E	13' 11-3/4"	15' 1-1/8"
723E to 1043E	18'	15' 1-1/8"
<b>7' 10" Wide Models</b>		
ATC-M203E to M233E	8' 11-1/2"	7' 10"
M301E to M380E	11' 11-3/4"	7' 10"
M426E to M591E	18'	7' 10"
M634E to M755E	13' 11-3/4"	16' 1-1/8"
<b>8-1/2' Wide Models</b>		
ATC-170E to 247E	8' 5-1/2"	7' 5-7/8"
218E to 305E	8' 11-1/2"	8' 5-1/2"
246E to 369E	10' 5-1/2"	8' 5-1/2"
358E to 409E	11' 11-3/4"	8' 5-1/2"
385E to 473E	13' 11-3/4"	8' 5-1/2"
486E to 630E	18'	8' 5-1/2"
666E to 755E	21'	8' 5-1/2"
<b>10' Wide Models</b>		
ATC-XE298E to XC462E	11' 11-3/4"	9' 9-3/4"
XE406E to XC669E	18'	9' 9-3/4"
XE596E to XC925E	24' 2"	9' 9-3/4"
XE812E to XC1340E	36' 2-1/2"	9' 9-3/4"
<b>17' Wide Models</b>		
ATC-639E to 805E	11' 11-3/4"	17' 4-1/8"
780E to 926E	13' 11-3/4"	17' 4-1/8"
<b>12' Wide Models</b>		
ATC-428E to 583E	11' 11-3/4"	11' 10"
545E to 647E	13' 11-3/4"	11' 10"
642E to 892E	18'	11' 10"
791E to 967E	20'	11' 10"
858E to 1167E	24' 2"	11' 10"
1164E to 1294E	28' 2"	11' 10"
1192E to 1784E	36' 2-1/2"	11' 10"
1625E to 1925E	40' 2-1/2"	11' 10"
<b>24' Wide Models</b>		
ATC-857E to 1166E	11' 11-3/4"	24' 1-1/8"
1163E to 1293E	13' 11-3/4"	24' 1-1/8"
1191E to 1783E	18'	24' 1-1/8"
1616E to 1915E	20'	24' 1-1/8"
1879E to 2320E	24' 2"	24' 1-1/8"
2256E to 2509E	28' 2"	24' 1-1/8"
2490E to 3459E	36' 2-1/2"	24' 1-1/8"
2855E to 3714E	40' 2-1/2"	24' 1-1/8"

## Electric Heaters

Electric immersion heaters are available, factory installed, in the basin of the condenser. They are sized to maintain a +40° F pan water temperature with the fans off and an ambient air temperature of 0°F, -20°F or -40°F. They are furnished with a thermostat to cycle the heater on, when required, and a low water protection device to prevent the heater elements from energizing unless they are completely submerged. All components are in weatherproof enclosures for outdoor use. The heater power contactors and electric wiring are not included as standard.

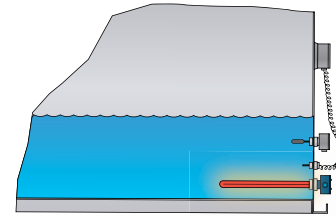

Heater Sizes (kW)			
Models	0°F	-20°F	-40°F
ATC-50E to 165E	3	4	5
90E to 120E	4	5	7
135E to 165E	5	7	9
ATC-181E to 261E	6	8	(2) 6
264E to 351E	(2) 4	(2) 6	(2) 8
268E to 411E	(2) 5	(2) 7	(2) 9
362E to 522E	(2) 6	(2) 8	(2) 12
528E to 702E	(4) 4	(4) 6	(4) 8
536E to 822E	(4) 5	(4) 7	(4) 9
724E to 1044E	(4) 6	(4) 8	(4) 12
361E to 521E	(2) 6	(2) 8	(4) 6
526E to 701E	(4) 4	(4) 6	(4) 8
535E to 821E	(4) 5	(4) 7	(4) 9
723E to 1043E	(4) 6	(4) 8	(4) 12
ATC-M203E to M233E	6	9	12
M301E to M380E	(2) 4	(2) 6	(2) 8
M426E to M591E	(2) 6	(2) 9	(2) 12
M634E to M755E	(4) 5	(4) 7	(4) 9
ATC-170E to 247E	6	8	12
218E to 305E	7	10	15
246E to 369E	8	12	15
358E to 409E	(2) 4	(2) 7	(2) 9
385E to 473E	(2) 5	(2) 7	(2) 10
486E to 630E	(2) 6	(2) 9	(2) 12
666E to 755E	(2) 7	(2) 12	(2) 15
ATC-639E to 805E	(4) 4	(4) 7	(4) 9
780E to 926E	(4) 5	(4) 7	(4) 10
ATC-XE298E to XC462E	(2) 5	(2) 8	(2) 10
XE406E to XC669E	(2) 7	(2) 12	(2) 15
XE596E to XC925E	(4) 5	(4) 8	(4) 10
XE812E to XC1340E	(4) 7	(4) 12	(4) 15
ATC-428E to 583E	(2) 6	(2) 9	(2) 12
545E to 647E	(2) 7	(2) 10	(2) 15
642E to 892E	(2) 9	(2) 15	(2) 18
791E to 967E	(2) 10	(2) 15	(3) 15
858E to 1167E	(4) 6	(4) 9	(4) 12
1164E to 1294E	(4) 7	(4) 10	(4) 15
1192E to 1784E	(4) 9	(4) 15	(4) 18
1625E to 1925E	(4) 10	(4) 15	(6) 15
ATC-857E to 1166E	(4) 6	(4) 9	(4) 12
1163E to 1293E	(4) 7	(4) 10	(4) 15
1191E to 1783E	(4) 9	(4) 15	(4) 18
1616E to 1915E	(4) 10	(4) 15	(4) 20
1879E to 2320E	(4) 12	(4) 18	(6) 15
2256E to 2509E	(4) 15	(4) 20	(6) 18
2490E to 3459E	(4) 18	(6) 18	(8) 18
2855E to 3714E	(4) 20	(6) 20	(8) 20

# Optional Equipment



**Pulse~Pure®** is an environmentally sensitive, non-chemical water treatment system

for evaporative condensers. Developed by EVAPCO, **Pulse~Pure®** offers an alternative to chemical water treatment programs. Utilizing pulse-power technology, **Pulse~Pure®** provides chemical-free treatment that is environmentally safe.

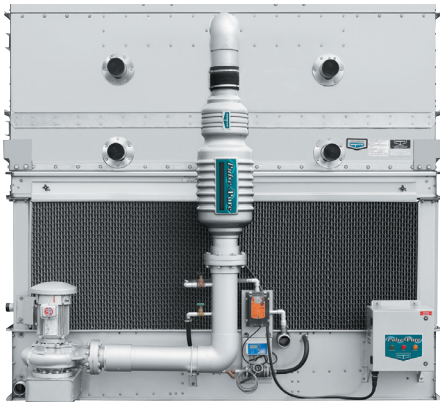

## Smart Shield® Solid Chemistry Water Treatment System



EVAPCO's SmartShield® solid chemistry water treatment system is an innovative solution to conventional liquid chemical programs. SmartShield® was developed

specifically for evaporative condensers and closed circuit coolers. The system comes factory mounted and includes all the components required for an effective water treatment system. Solid products eliminate the potential for liquid spills making it easier and safer to use. Controlled release chemistry provides uniform treatment over a 30 day period.

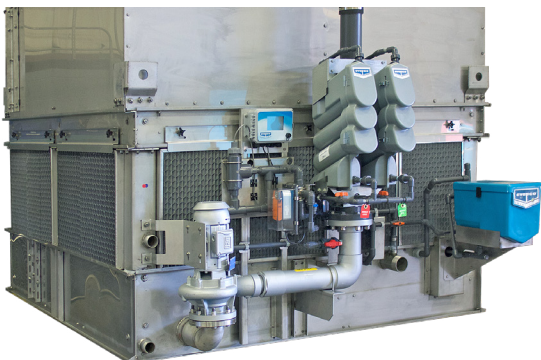

## Multiple Circuit Coils

Condensers may be supplied with multiple circuit coils to match various system requirements, such as split systems, or if a glycol or water circuit is desired for compressor head cooling.

## ASME Coils

Evaporative condensers can be furnished with condensing coils manufactured in accordance with the ASME Pressure Vessel Code Section VIII, Division I. Coils built with this option will bear a U-stamp indicating their compliance with the ASME code.

## TITAN Coils – Stainless Steel Construction

EVAPCO offers the options of Type 304L or Type 316L stainless steel construction using the Thermal Pak® II coil design. Highly efficient heat transfer coils with the ultimate corrosion protection.

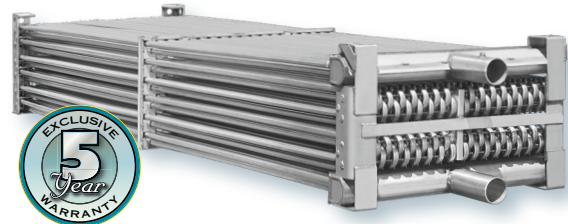

## Stainless Steel Basin

ATC-E condensers are available with an inexpensive all stainless steel basin section. This provides superior corrosion resistance over other materials of construction.

## Self-Supporting Service Platforms

Condensers are available with self-supporting service platforms that include access ladders which are designed for easy field installation. This option offers significant savings in comparison to field constructed, externally supported catwalks. The Evapco service platform option is located at each maintenance access door.

# Optional Equipment

## Super Low Sound Fan

EVAPCO's Super Low Sound Fan utilizes an extremely wide chord blade design and is ideal for low energy, sound sensitive installations without sacrificing thermal performance. This revolutionary technology is one-piece molded, heavy duty fiberglass reinforced polyester hub and blade construction utilizing a forward swept blade design. The Super Low Sound Fan is capable of reducing the unit sound pressure levels 9 dB(A) to 15 dB(A) depending on specific unit selection and measurement location.



## Dual Fan Option

Evapco now offers a Dual Fan arrangement on 10x18, 12x18 and 12x20 nominal box sizes. The Dual Fan option gives users redundancy in large box sizes by providing independent motors, fans, and drives that previously only had a single fan and motor.

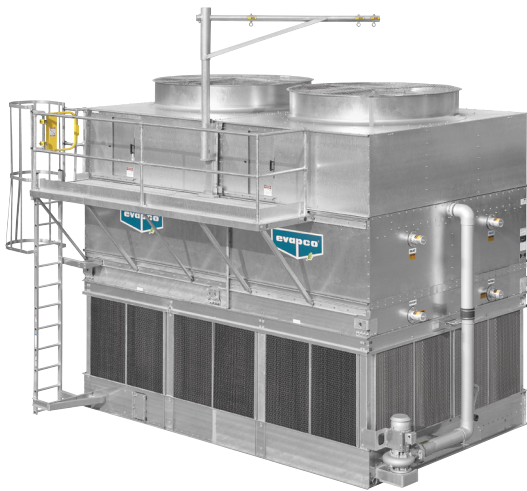

## Electric Water Level Control

Evaporative condensers may be ordered with an electric water level control in lieu of the standard mechanical float and make-up assembly. This package provides accurate control of water levels and does not require field adjustment.



## Motor Davit

In the event that a fan motor should need to be replaced, a lightweight motor davit is available from which a chain fall can be mounted to easily lower the motor to the ground.

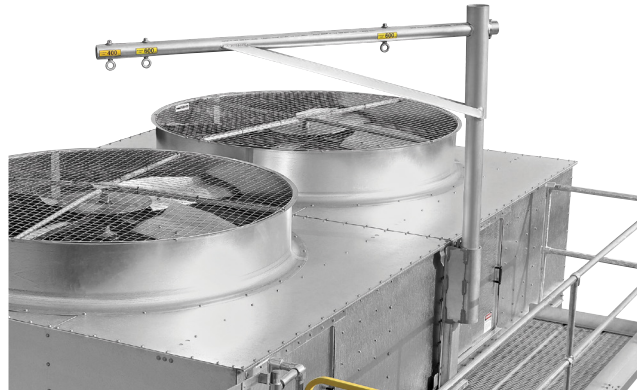

ATC-E Condenser with Optional Service Platform and Motor Davit

## Remote Sump Configuration

For units operating in areas where temperatures may be very low, or where low temperatures may occur during periods when the unit is not operating, a sump located inside the building is the preferred means of ensuring that the basin water will not freeze. For these applications, the condenser will be supplied without the spray pump, suction strainers and all associated piping, but with an oversized bottom outlet.

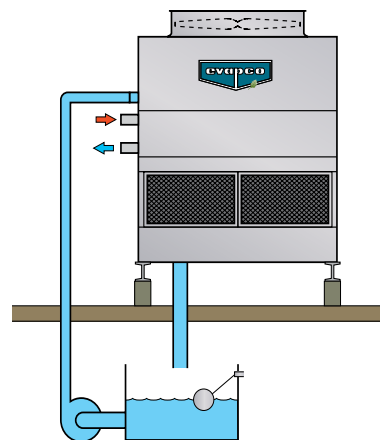



# ATC-E Application

## Design

EVAPCO units are heavy-duty construction and designed for long trouble-free operation. Proper equipment selection, installation and maintenance are, however, necessary to ensure good unit performance. Some of the major considerations in the application of a condenser are presented below. For additional information, contact the factory.

## Structural Steel Support

The method of support for EVAPCO condensers is two structural "I" beams located under the outer flanges and running the entire length of the unit. Mounting holes, 3/4" in diameter, are located in the bottom channels of the pan section to provide for bolting to the structural steel; refer to certified drawings from the factory for bolt hole locations.

Beams should be level to within 1/8" in 6' before setting the unit in place. Do not level the unit by shimming between it and the "I" beams as this will not provide proper longitudinal support.

**NOTE: Consult IBC for required steel support layout and structural design.**

## Air Circulation

In reviewing the system design and unit location, it is important that proper air circulation be provided. The best location is on an unobstructed roof top or on ground level away from walls and other barriers. Care must be taken when locating condensers in wells or enclosures or next to high walls. The potential for recirculation of hot, moist discharge air back into the fan intake exists. Recirculation raises the wet bulb temperature of the entering air causing the condensing pressure to rise above the design. For these cases, a discharge hood or ductwork should be provided to raise the overall unit height even with the adjacent wall, thereby reducing the chance of recirculation. Good engineering practice dictates that the evaporative condenser's discharge air not be directed or located close to, or in the vicinity of, building air intakes. Engineering assistance is available from the factory to identify potential recirculation problems and recommend solutions.

For additional information regarding layout of evaporative condensers, see EVAPCO Bulletin entitled "**Equipment Layout**".

## Piping

Condenser piping should be designed and installed in accordance with generally accepted engineering practice. All piping should be anchored by properly designed hangers and supports with allowance made for possible expansion and contraction. No external loads should be placed upon condenser connections, nor should any of the pipe supports be anchored to the unit framework. For additional information concerning refrigerant pipe sizing and layout, see EVAPCO Bulletin entitled "**Piping Evaporative Condensers**".

## Maintaining the Recirculated Water System

The heat rejection in a condenser is accomplished by the evaporation of a portion of the recirculated spray water. As this water evaporates, it leaves behind all of its mineral content and impurities. Therefore, it is important to bleed-off an amount of water equal to that which is evaporated to prevent the build-up of these impurities. If this is not done, the mineral or the acidic nature of the water will continue to increase. This will ultimately result in heavy scaling or a corrosive condition.

## Bleed-off

Each unit supplied with a pump mounted on the side is furnished with a clear bleed line for visual inspection and a valve which, when fully open, will bleed-off the proper amount of water. If the make-up water supplying the unit is relatively free of impurities, it may be possible to cut back the bleed, but the unit must be checked frequently to make sure scale is not forming. Make-up water pressure should be maintained between 20 and 50 psig.

## Water Treatment

A proper water treatment program is an essential part of routine maintenance in order to help assure proper operation and longevity of the unit. To help prevent the formation of "white rust", the interior of the unit should be passivated during start-up and monitored periodically as part of the water treatment program. For more information about white rust, please request a copy of EVAPCO Engineering Bulletin 36. A qualified water treatment company should be contacted to design a water treatment protocol specifically based on applicable location, water quality and unit materials of construction.

If acid is used for treatment, it should be accurately metered and the concentration properly controlled. **The pH of the water should be maintained between 6.5 and 8.0. Units constructed of galvanized steel operating with circulating water having a pH of 8.3 or higher will require periodic passivation of the galvanized steel to prevent the formation of "white rust"**. Batch chemical feeding is not recommended because it does not afford the proper degree of control. If acid cleaning is required, extreme caution must be exercised and only inhibited acids recommended for use with galvanized construction should be used.

**NOTE: Operating the condenser below 6.0 pH for any period of time may cause the removal of the protective zinc coating on the galvanized steel components.**

For more information see EVAPCO Bulletin entitled "**Maintenance Instructions**".

## Control of Biological Contamination

Water quality should be checked regularly for biological contamination. If biological contamination is detected, a more aggressive water treatment and mechanical cleaning program should be undertaken. The water treatment program should be performed in conjunction with a qualified water treatment company. It is important that all internal surfaces be kept clean of accumulated dirt and sludge. In addition, the drift eliminators should be maintained in good operating condition.

## Solutions for Sound Sensitive Applications

The ATC-E product line is now available with four (4) equipment options to reduce the overall sound generated from the side or top of the unit. Each option provides various levels of sound reduction and can be used in combination to provide the lowest sound level. If a detailed analysis or full octave band data sheet is required for your application, please consult your EVAPCO Sales Representative.

**NOTE: These low sound options may impact the overall installed dimensions and weight of the unit.**

# ATC-E Mechanical Specifications

Furnish and install, as shown on the plans, an EVAPCO model \_\_\_\_\_ induced draft, counterflow evaporative condenser with a condensing capacity of \_\_\_\_\_ MBH total heat of rejection when operating with \_\_\_\_\_ refrigerant at \_\_\_\_\_ °F condensing temperature with a \_\_\_\_\_ °F design wet bulb temperature.

## IBC Compliance

The condenser shall be designed and constructed to meet the International Building Code (IBC ) specifications for installed components per ASCE. The manufacturer shall provide a certificate of compliance to demonstrate that the equipment/unit has been independently tested and certified in accordance with the IBC program.

## Basin and Casing

The basin and casing shall be constructed of G-235 hot-dip galvanized steel for long life and durability. Standard basin accessories shall include overflow, drain, type 304 stainless steel strainers, and brass make-up valve with plastic float.

## Models ATC-50E to ATC-926E

### Fan Motor

\_\_\_\_\_horsepower, totally enclosed, fan- cooled motors with 1.15 service factor shall be furnished suitable for outdoor service on \_\_\_\_\_volts, \_\_\_\_\_hertz, and \_\_\_\_\_phase. Motor(s) shall be mounted on an adjustable base which is accessible from the outside of the unit for service. A swing away protective cover shall shield the motor and sheave from the weather.

### Drive

The fan drive shall be multigroove, solid back V-belt type with taper lock bushings designed for 150% of the motor nameplate horsepower. The belt material shall be neoprene reinforced with polyester cord and specifically designed for evaporative condenser service. Fan sheave shall be aluminum alloy construction. The fans and the fan sheaves shall be mounted on the shaft with a specially coated bushing to provide maximum corrosion protection. Belt adjustment shall be accomplished from the exterior of the unit. Bearing lube lines shall be extended to the exterior of the unit for easy maintenance.

## Models ATC-XE298E to ATC-XC1340E, ATC-428E to ATC-3714E

### Fan Motor

\_\_\_\_\_horsepower, totally enclosed, air-over ball bearing fan motor(s), with 1.15 service factor shall be furnished suitable for service on \_\_\_\_\_volts, \_\_\_\_\_hertz, and \_\_\_\_\_phase. Motor(s) shall be mounted on an adjustable base which allows the motor to swing to the outside of the unit for servicing.

### Drive

The fan drive shall be a multigroove, solid back V-belt type with taper lock bushings designed for 150% of the motor nameplate horsepower. The belt material shall be neoprene reinforced with polyester cord and specifically designed for evaporative condenser service. Fan and motor sheaves shall be aluminum alloy construction. The fans and fan sheaves shall be mounted on the shaft with a specially coated bushing to provide maximum corrosion protection. Belt adjustment shall be accomplished

from the exterior of the unit. Bearing lube lines shall be extended to the exterior of the unit for easy maintenance.

## Axial Propeller Fans

Fans shall be heavy duty, axial propeller-type, statically balanced. The fans shall be constructed of aluminum alloy or fiberglass reinforced polypropylene blades, installed in a closely fitted cowl with venturi air inlet. Fan screens shall be galvanized steel mesh and frame, bolted to the fan cowl.

## Fan Shaft Bearings

Fan shaft bearings shall be heavy duty self-aligning ball type with grease fittings extended to the outside of the unit. Bearings shall be designed for a minimum L-10 life of 75,000 hours.

## Water Recirculation Pump

The pump(s) shall be a close-coupled, centrifugal type with mechanical seal, installed vertically at the factory to allow free drainage on shut down. \_\_\_\_\_horsepower, totally enclosed motor(s) shall be furnished suitable for outdoor service on \_\_\_\_\_volts, \_\_\_\_\_hertz, and \_\_\_\_\_phase.

## Heat Transfer Coil

Condensing coil(s) shall be all prime surface steel, encased in a steel framework and hot-dip galvanized after fabrication as a complete assembly. The coil(s) shall be designed with sloping tubes for free drainage. Coils shall have a design pressure of 300 psig and shall be in compliance with ANSI/ASME B31.5 Refrigerant Piping and Heat Transfer Components. The coil shall be strength tested in accordance with ANSI/ASME B31.5 and subsequently leak tested using air under water.

## Water Distribution System

The system shall provide a water flow rate of 6 GPM over each square foot of unit face area to ensure proper flooding of the coil. The spray header shall be constructed of Schedule 40 polyvinyl chloride (PVC) pipe for corrosion resistance. All spray branches shall be removable for cleaning. Heavy-duty ABS spray nozzles with large 1-1/4" diameter opening and internal sludge ring to eliminate clogging. Nozzles shall be threaded into spray header to provide easy removal for maintenance.

## Eliminators

The eliminators shall be constructed entirely of inert polyvinyl chloride (PVC) in easily handled sections. The eliminator design shall incorporate three changes in air direction to assure complete removal of all entrained moisture from the discharge air stream. Maximum drift rate shall be less than 0.001% of the circulating water rate.

## Louvers

The louvers shall be constructed from polyvinyl chloride (PVC). The louvers shall be mounted in easily removable sections for access to the pan for maintenance. The louvers shall have a minimum of two changes in air direction to prevent splash-out and block direct sunlight.

## Finish

All basin and casing materials shall be constructed of G-235 heavy gauge mill hot-dip galvanized steel. During fabrication, all panel edges shall be coated with a 95% pure zinc-rich compound for superior protection against corrosion.





OUR PRODUCTS ARE MANUFACTURED WORLDWIDE.



★ World Headquarters/  
Research and  
Development Center  
■ EVAPCO Facilities

**EVAPCO, Inc. — World Headquarters & Research / Development Center**

P.O. Box 1300 • Westminster, MD 21158 USA  
410-756-2600 • marketing@evapco.com • evapco.com

**North America**

**EVAPCO, Inc.**  
World Headquarters  
Westminster, MD USA  
410.756.2600  
marketing@evapco.com

**EVAPCO East**  
Taneytown, MD USA  
410.756.2600  
marketing@evapco.com

**EVAPCO East**  
Key Building  
Taneytown, MD USA  
410.756.2600  
marketing@evapco.com

**EVAPCO Midwest**  
Greenup, IL USA  
217.923.3431  
evapcomw@evapcomw.com

**EVAPCO West**  
Madera, CA USA  
559.673.2207  
contact@evapcowest.com

**EVAPCO Iowa**  
Lake View, IA USA  
712.657.3223

**EVAPCO Iowa**  
Sales & Engineering  
Medford, MN USA  
507.446.8005  
evapcomn@evapcomn.com

**EVAPCO Newton**  
Newton, IL USA  
618.783.3433  
evapcomw@evapcomw.com

**Evapcold Manufacturing**  
Greenup, IL USA  
217.923.3431  
evapcomw@evapcomw.com

**EVAPCO Dry Cooling, Inc.**  
Bridgewater, NJ USA  
908.379.2665  
info@evapcodc.com

**EVAPCO Dry Cooling, Inc.**  
Littleton, CO USA  
908.379.2665  
info@evapcodc.com  
Spare Parts: 908.895.3236  
Spare Parts: spares@evapcodc.com

**EVAPCO Power México S. de R.L. de C.V.**  
Mexico City, Mexico  
(52) 55.8421.9260  
info@evapcodc.com

**Refrigeration Vessels & Systems Corporation**  
A wholly owned subsidiary of EVAPCO, Inc.  
Bryan, TX USA  
979.778.0095  
rvs@rvscorp.com

**EvapTech, Inc.**  
A wholly owned subsidiary of EVAPCO, Inc.  
Edwardsville, KS USA  
913.322.5165  
marketing@evaptech.com

**Tower Components, Inc.**  
A wholly owned subsidiary of EVAPCO, Inc.  
Ramseur, NC USA  
336.824.2102  
mail@towercomponentsinc.com

**EVAPCO Alcoil, Inc.**  
A wholly owned subsidiary of EVAPCO, Inc.  
York, PA USA  
717.347.7500  
info@evapco-alcoil.com

**Europe**

**EVAPCO Europe BVBA**  
European Headquarters  
Tongeren, Belgium  
(32) 12.39.50.29  
evapco.europe@evapco.be

**EVAPCO Europe, S.r.l.**  
Milan, Italy  
(39) 02.939.9041  
evapcoeuropa@evapco.it

**EVAPCO Europe, S.r.l.**  
Sondrio, Italy

**EVAPCO Europe GmbH**  
Meerbusch, Germany  
(49) 2159.69560  
info@evapco.de

**EVAPCO Air Solutions**  
A wholly owned subsidiary of EVAPCO, Inc.  
Aabybro, Denmark  
(45) 9824.49999  
info@evapco.dk

**EVAPCO Air Solutions GmbH**  
Garbsen, Germany  
(49) 5137.938750  
info@evapcoas.de

**Evap Egypt Engineering Industries Co.**  
A licensed manufacturer of EVAPCO, Inc.  
Nasr City, Cairo, Egypt  
(202) 24044997 / (202) 24044998  
mmanz@tiba-group.com / hany@tiba-group.com

**EVAPCO Middle East DMCC**  
Dubai, United Arab Emirates  
(971) 4.448.7242  
info@evapco.ae

**EVAPCO S.A. (Pty.) Ltd.**  
A licensed manufacturer of EVAPCO, Inc.  
Isando, South Africa  
(27) 11.392.6630  
evapco@evapco.co.za

**Asia Pacific**

**EVAPCO Asia Pacific Headquarters**  
Baoshan Industrial Zone  
Shanghai, P.R. China  
(86) 21.6687.7786  
marketing@evapcochina.com

**EVAPCO (Shanghai) Refrigeration Equipment Co., Ltd.**  
Baoshan Industrial Zone, Shanghai, P.R. China  
(86) 21.6687.7786  
marketing@evapcochina.com

**EVAPCO (Beijing) Refrigeration Equipment Co., Ltd.**  
Huairou District, Beijing, P.R. China  
(86) 10.6166.7238  
marketing@evapcochina.com

**EVAPCO Air Cooling Systems (Jiaxing) Company, Ltd.**  
Jiaxing, Zhejiang, China  
(86) 573.8311.9379  
info@evapcochina.com

**EVAPCO Australia (Pty.) Ltd.**  
Riverstone, NSW, Australia  
(61) 02.9627.3322  
sales@evapco.com.au

**EvapTech Asia Pacific Sdn. Bhd**  
A wholly owned subsidiary of EvapTech, Inc.  
Puchong, Selangor, Malaysia  
(60) 3.8070.7255  
marketing-ap@evaptech.com

**South America**

**EVAPCO Brasil**  
Equipamentos Industriais Ltda.  
Indaiatuba, São Paulo, Brazil  
(55) 11.5681.2000  
vendas@evapco.com.br

**FanTR Technology Resources**  
Indaiatuba, São Paulo, Brazil  
(55) 11.4025.1670  
fantr@fantr.com

Bulletin ATC22ENG  
2M/11-20/DGD

©2020 EVAPCO, Inc.

Committed to making life easier, more reliable and more sustainable for people everywhere