

# Rigging & Assembly Instructions

## ICE-PAK® MODULAR ICE TANK



Mr. GoodTower®



Bulletin IP24RIG

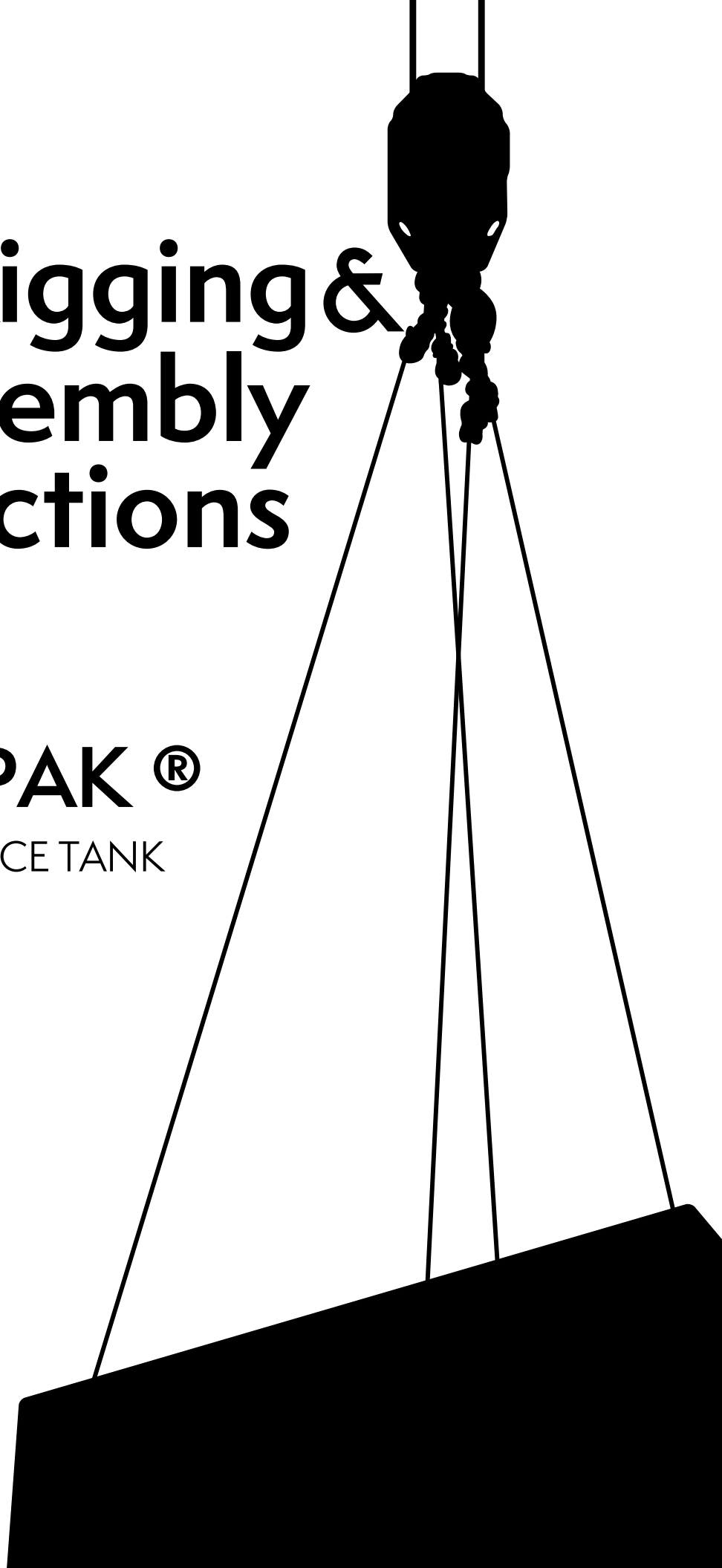



# Table of Contents

---

Shipment ..... 1  
Rigging..... 2  
Site Preparation ..... 3  
Glycol Connections ..... 4  
Charging System with Glycol ..... 4  
Filling Tank with Water ..... 5  
Water Quality ..... 5  
Operation and Maintenance Instructions ..... 6  
Notes ..... 7

The ICE-PAK® MODULAR ICE TANK should be rigged, assembled, and maintained using the instructions and recommendations outlined in this bulletin.

All personnel should review these procedures, as well as the latest industry-approved installation practices, prior to rigging and assembly. The information in this bulletin is for informational purposes only. These instructions do not purport to cover all variations and possible contingencies in connection with installation. Additionally, the procedures described therein are subject to change without prior notice, due to EVAPCO, Inc.'s ongoing research and development.

EVAPCO, Inc. makes no representations or warranties with respect to these instructions or the products described herein. Nor shall EVAPCO, Inc. be responsible for any loss or damage (direct, indirect, consequential, or other) during installation or handling of equipment after shipment.

*For a full description of EVAPCO's liability policy, please visit [www.evapco.com](http://www.evapco.com) to access our Terms and Conditions.*

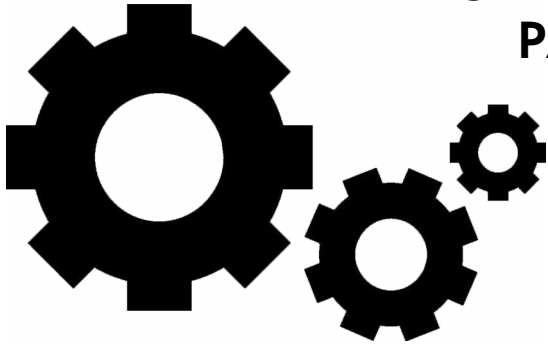

**FOR EVAPCO AUTHORIZED  
PARTS AND SERVICE,  
CONTACT YOUR  
LOCAL EVAPCO  
REPRESENTATIVE  
OR THE LOCAL  
SERVICE CENTER**



**Mr. GoodTower®**



**EVAPCO, Inc. — World Headquarters & Research / Development Center**

P.O. Box 1300 • Westminster, MD 21158 USA  
410.756.2600 • [marketing@evapco.com](mailto:marketing@evapco.com) • [evapco.com](http://evapco.com)

**North America**

**EVAPCO, Inc.**  
**World Headquarters**  
Westminster, MD USA  
410.756.2600  
[marketing@evapco.com](mailto:marketing@evapco.com)

**EVAPCO East**  
Taneytown, MD USA

**EVAPCO East**  
Key Building  
Taneytown, MD USA

**EVAPCO Midwest**  
Greenup, IL USA  
217.923.3431  
[evapcomw@evapcomw.com](mailto:evapcomw@evapcomw.com)

**Evapcold Manufacturing**  
Greenup, IL USA

**EVAPCO West**  
Madera, CA USA  
559.673.2207  
[contact@evapcowest.com](mailto:contact@evapcowest.com)

**EVAPCO Alcoil, Inc.**  
York, PA USA  
717.347.7500  
[info@evapco-alcoil.com](mailto:info@evapco-alcoil.com)

**EVAPCO Iowa**  
Lake View, IA USA

**EVAPCO Iowa**  
Sales & Engineering  
Medford, MN USA  
507.446.8005  
[evapcomn@evapcomn.com](mailto:evapcomn@evapcomn.com)

**EVAPCO LMP ULC**  
Laval, Quebec, Canada  
450.629.9864  
[info@evapcolmp.ca](mailto:info@evapcolmp.ca)

**EVAPCO Select Technologies, Inc.**  
Belmont, MI USA  
844.785.9506  
[emarketing@evapcoselect.com](mailto:emarketing@evapcoselect.com)

**Refrigeration Vessels &  
Systems Corporation**  
Bryan, TX USA  
979.778.0095  
[rvs@rvscorp.com](mailto:rvs@rvscorp.com)

**Tower Components, Inc.**  
Ramseur, NC USA  
336.824.2102  
[mail@towercomponentsinc.com](mailto:mail@towercomponentsinc.com)

**EvapTech, Inc.**  
Edwardsville, KS USA  
913.322.5165  
[marketing@evaptech.com](mailto:marketing@evaptech.com)

**EVAPCO Dry Cooling, Inc.**  
Bridgewater, NJ USA  
908.379.2665  
[info@evapcodc.com](mailto:info@evapcodc.com)

**EVAPCO Dry Cooling, Inc.**  
Littleton, CO USA  
908.895.3236  
[info@evapcodc.com](mailto:info@evapcodc.com)

**EVAPCO Power México S. de R.L. de C.V.**  
Mexico City, Mexico  
(52) 55.8421.9260  
[info@evapcodc.com](mailto:info@evapcodc.com)

**Asia Pacific**

**EVAPCO Asia Pacific  
Headquarters**  
Baoshan Industrial Zone Shanghai, P.R. China  
(86) 21.6687.7786  
[marketing@evapcochina.com](mailto:marketing@evapcochina.com)

**EVAPCO (Shanghai)  
Refrigeration Equipment Co., Ltd.**  
Baoshan Industrial Zone, Shanghai, P.R. China

**EVAPCO (Beijing)  
Refrigeration Equipment Co., Ltd.**  
Huairou District, Beijing, P.R. China  
(86) 10.6166.7238  
[marketing@evapcochina.com](mailto:marketing@evapcochina.com)

**EVAPCO Air Cooling Systems  
(Jiaxing) Company, Ltd.**  
Jiaxing, Zhejiang, P.R. China  
(86) 573.8311.9379  
[info@evapcochina.com](mailto:info@evapcochina.com)

**EVAPCO Australia (Pty.) Ltd.**  
Riverstone, NSW, Australia  
(61) 02.9627.3322  
[sales@evapco.com.au](mailto:sales@evapco.com.au)

**EvapTech (Shanghai)  
Cooling Tower Co., Ltd.**  
Baoshan District, Shanghai, P.R. China  
Tel: (86) 21.6478.0265

**EvapTech Asia Pacific Sdn. Bhd.**  
Puchong, Selangor, Malaysia  
(60) 3.8070.7255  
[marketing-ap@evaptech.com](mailto:marketing-ap@evaptech.com)

**Europe | Middle East | Africa**

**EVAPCO Europe  
EMENA Headquarters**  
Tongeren, Belgium  
(32) 12.39.50.29  
[evapco.europe@evapco.be](mailto:evapco.europe@evapco.be)

**EVAPCO Europe BV**  
Tongeren, Belgium

**EVAPCO Europe, S.r.l.**  
Milan, Italy  
(39) 02.939.9041  
[evapcoeurope@evapco.it](mailto:evapcoeurope@evapco.it)

**EVAPCO Europe, S.r.l.**  
Sondrio, Italy

**EVAPCO Europe A/S**  
Aabybro, Denmark  
(45) 9824.4999  
[info@evapco.dk](mailto:info@evapco.dk)

**EVAPCO Europe GmbH**  
Meerbusch, Germany  
(49) 2159.69560  
[info@evapco.de](mailto:info@evapco.de)

**EVAPCO Middle East DMCC**  
Dubai, United Arab Emirates  
(971) 56.991.6584  
[info@evapco.ae](mailto:info@evapco.ae)

**Evap Egypt Engineering Industries Co.**  
*A licensed manufacturer of EVAPCO, Inc.*  
Nasr City, Cairo, Egypt  
(20) 10.054.32.198  
[evapco@tiba-group.com](mailto:evapco@tiba-group.com)

**EVAPCO S.A. (Pty.) Ltd.**  
*A licensed manufacturer of EVAPCO, Inc.*  
Isando, South Africa  
(27) 11.392.6630  
[evapco@evapco.co.za](mailto:evapco@evapco.co.za)

**South America**

**EVAPCO Brasil**  
*Equipamentos Industriais Ltda.*  
Indaiatuba, São Paulo, Brazil  
(55) 11.5681.2000  
[vendas@evapco.com.br](mailto:vendas@evapco.com.br)

**FanTR Technology Resources**  
Itu, São Paulo, Brazil  
(55) 11.4025.1670  
[fantr@fantr.com](mailto:fantr@fantr.com)

**TECHNOLOGY FOR THE FUTURE, AVAILABLE TODAY**  
Visit EVAPCO's website: [evapco.com](http://evapco.com)

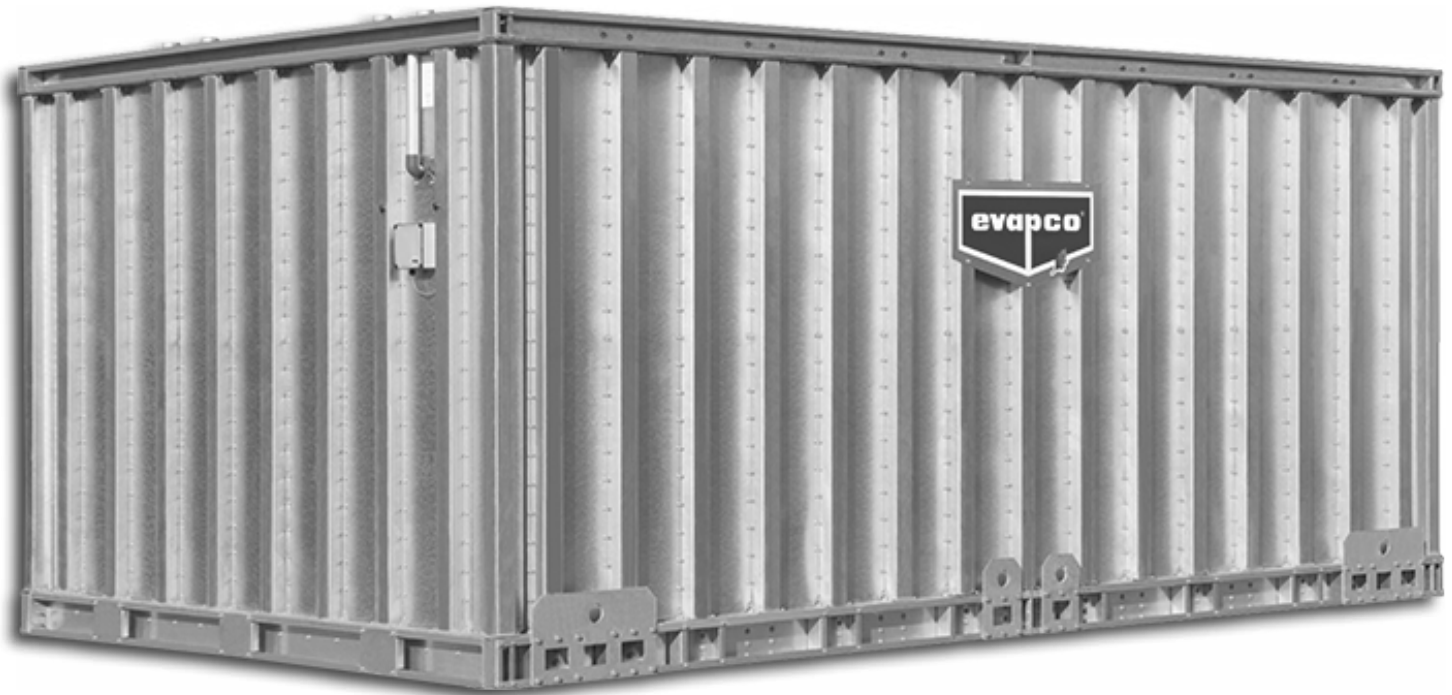

## Shipment

---

The ICE-PAK® ice thermal storage units are factory assembled to minimize installation time in the field. Upon delivery of equipment to job site or riggers yard, thoroughly inspect each unit to ensure no shipping damage has occurred using the following checklist:

- Exterior Panels
- Covers
- Inspection Hatch
- Ice Coils
- Sight Tube & Cover
- Inventory Controller (If Equipped)

**NOTE:** *If you discover any issues, report a damage claim with the carrier prior to accepting the unit.*

## Rigging

Before rigging any ICE-PAK® Modular Ice Tank, verify the unit weight using **Table 1**.

**Table 1** – Unit Weights by Model Number

ICE-PAK® Model Number	Shipping Weight (lbs)	Shipping Weight (kg)
370TD	20,550	9,321.32
480TD	24,580	11,149.30
590TD	28,320	12,845.74
476TE	23,650	10,727.46
620TE	28,160	12,773.16
760TE	32,730	14,846.08
625TH	29,530	13,394.58
815TH	34,790	15,780.48
1000TH	40,890	18,547.39

Lifting devices have been designed into the ICE-PAK® tank, as shown in **Figure 1**, and should only be used for moving the tank short distances and/or for final positioning of the unit. The use of spreader bars spanning the full width of the unit is required between cables, so damage does not occur to the unit. The use of safety slings is recommended for extended lifts or wherever hazards exist. Skids should remain on unit when using slings to prevent damage.

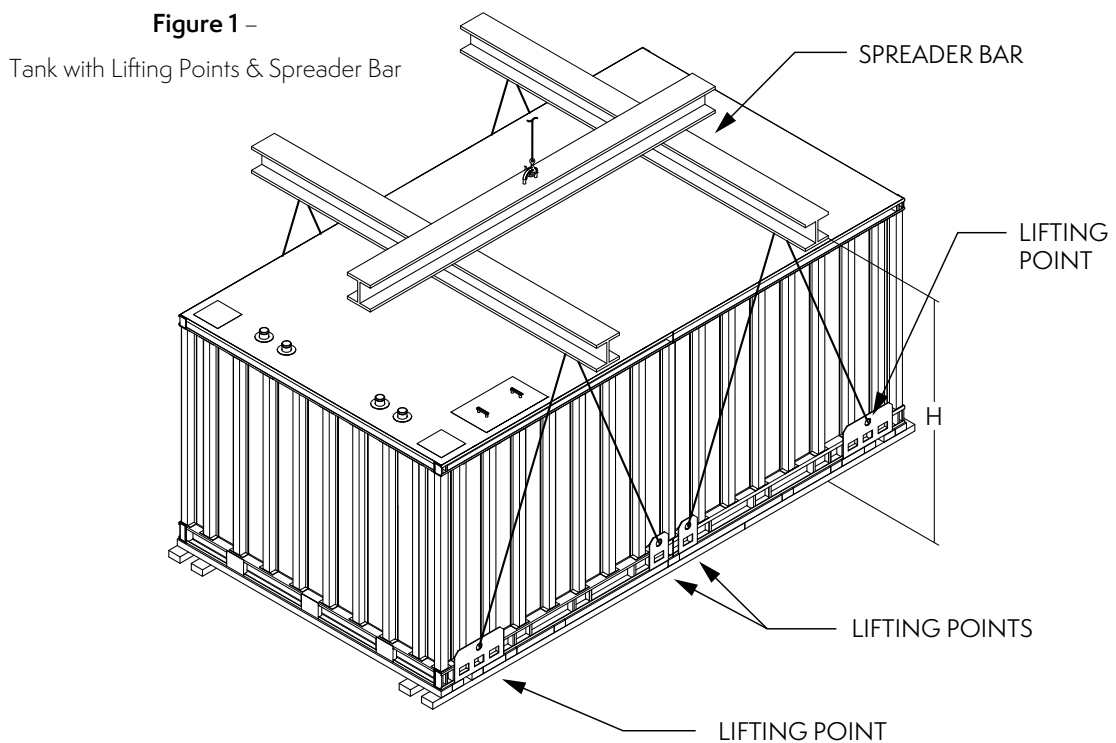



For reference, you'll find the minimum height requirements for each ICE-PAK® model in **Table 2**.

**Table 2 – Minimum Height Requirements**

ICE-PAK® Model	Minimum Height (H)	
	Customary (U.S.)	Metric
TD	7' 8"	2.34 m
TE	9' 2"	2.79 m
TH	11' 6"	3.51 m

If mechanical rollers or air lift glides are to be used to move or position the tank, the rollers or glides are to be located under the rigging points of the tank, as illustrated in **Figure 2**.

**Figure 2 –**  
Mechanical Rollers and/or Air Lift Glides Placement

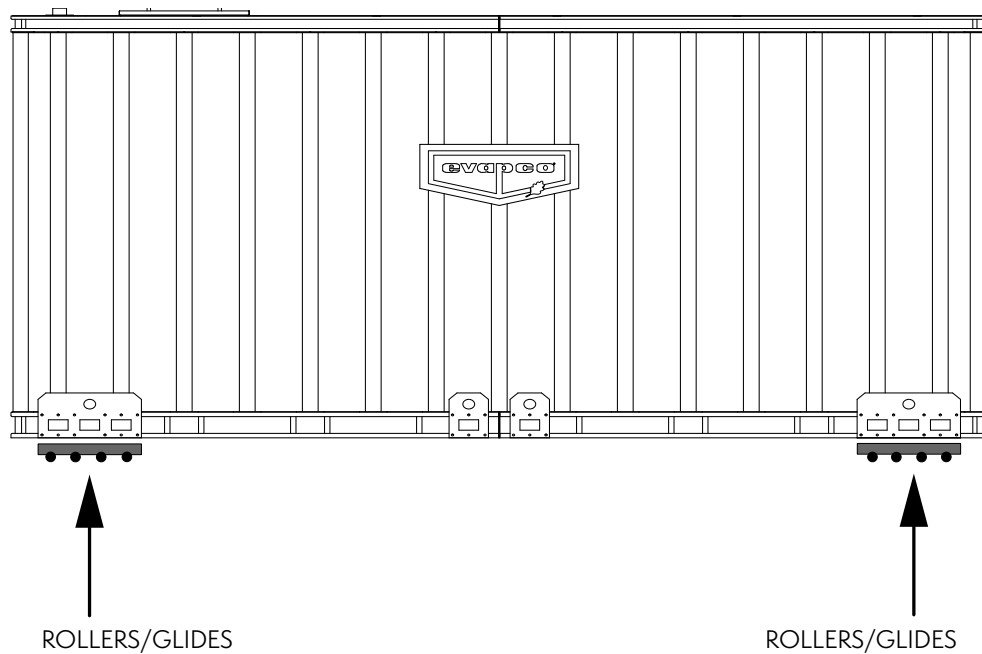

## Site Preparation

The site levelness is required to be flat and level to 1/4" (or 0.635 cm) within a ten (10) foot span (or three meter span). No shimming is allowed. The use of an elevated platform constructed of steel is not permitted. The concrete pad must be capable of supporting the ICE-PAK® unit filled with water and glycol solution. Refer to the unit's certified drawing for this operating weight.

## Glycol Connections

Standard inlets and outlets (as illustrated in **Figure 3**) are grooved for Victaulic connection. Welding is not recommended at these connections, as it will damage the tank cover and insulation.

Ensure that all external pipework is properly supported. There should not be any stress on the ICE-PAK® connections.

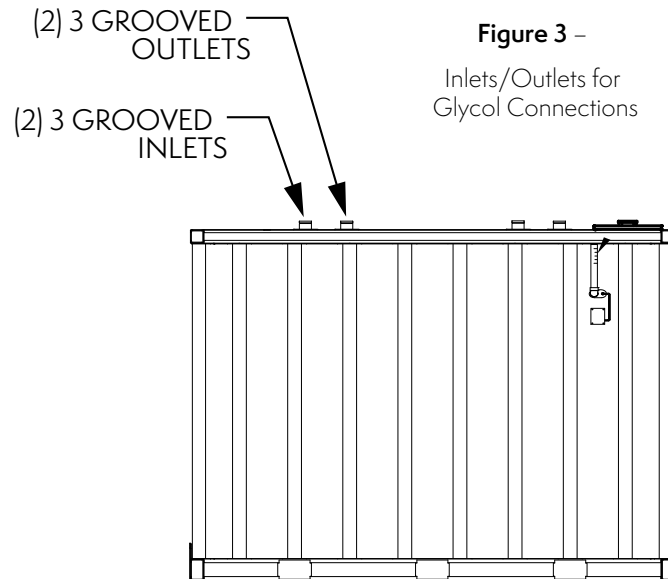

## Charging System with Glycol

Air vents are recommended at the high point of the system to aid in the filling and air evacuation of the filling process. ICE-PAK® units are not supplied with vents installed, unless noted on the certified drawing(s).

Isolation valves are recommended for each tank installed.

The system should be filled with an industrial grade **inhibited** glycol solution based on design criteria provided by EVAPCO, Inc. The glycol solution should be delivered premixed or mixed prior to filling the coils to prevent possible freeze damage caused by unmixed water and glycol during operations.

To fill the system:

1. Open high point vent.
2. Open all system valves—automated, service, and isolation—allowing the glycol to flow freely throughout the system.

This will push the air out of the system through the vents.



## Filling Tank with Water

Fill the tank with clean water meeting the specifications regarding water quality in **Table 3**. Fill level should be to the (0%) zero percent mark as indicated on the visual sight tube located on the connection end of the ICE-PAK® unit. The zero percent mark relates to approximately two (2) inches of water covering the uppermost part of the ice coils. Once the tank water is cooled to 40°F (4.44°C) during commissioning, then a calibration can be performed on the inventory controller, if provided, prior to the first ice build cycle.

## Water Quality

EVAPCO ice coils are hot dip galvanized to prevent corrosion. In addition, the very cold temperatures of the water in the ICE-PAK® tank inhibit the corrosion process. See **Table 3** below for the required water quality guidelines.

**Table 3 – Water Quality Guidelines**

Parameter	Range
pH	7.0 to 8.2
Hardness as CaCO <sub>3</sub>	50 to 500 ppm
Alkalinity as CaCO <sub>3</sub>	75 to 400 ppm
Chlorides as Cl	< 125 ppm
Total Dissolved Solids	< 1,000 ppm
Sulfates as SO <sub>4</sub>	Less than 250 ppm

**NOTE:**

- Tank water must **NOT** be treated with chemicals that will alter the freezing point of water.
- Your water treatment program should incorporate maintaining clean water, keeping suspended solids below limits as if left to accumulate on the coil surface, it may promote adverse conditions for the ice coils.



## ICE-PAK® Operating and Maintenance Instructions

Table 4 – Recommended Maintenance Schedule

Unit Service	Start Up	Quarterly	Monthly	Every 6 Months	Annually
Condition of Unit	X			X	X
Check Water Level	X			X	
Calibrate Inventory Controller	X			X	
Test Glycol Properties	X				X
Check Glycol Piping Loop	X				X
Check Controls for Proper Operation	X		X		
Analyze Water Quality (1st year of operation)	X	X			
If Water Quality is Holding After 1st Year Move				X	

**NOTE:** Maintenance should be performed more often than the recommended schedule in Table 4 if the ICE-PAK® unit is located or operated where conditions are unusually severe.

### Water Parameters:

Table 5 – Recommended Water Parameters

	Standard Operational Limits
pH	7.0 to 8.2
Calcium Hardness as CaCO <sub>3</sub> (ppm)	50 to 500 ppm
Sulfates as SO <sub>4</sub> (ppm)	Less than 250 ppm
Alkalinity as CaCO <sub>3</sub> (ppm)	75 to 400 ppm
Chlorides as Cl (ppm)	Less than 125 ppm
Total Dissolved Solids (ppm)	Less than 1000 ppm

**NOTE:**

- Tank water must **NOT** be treated with chemicals that will alter the freezing point of water.
- Your water treatment program should incorporate maintaining clean water, keeping suspended solids below limits as if left to accumulate on the coil surface, it may promote adverse conditions for the ice coils.



**NOTES:**



**NOTES:**



**EVAPCO, Inc.** • P.O. Box 1300 • Westminster, MD 21158 USA  
410.756.2600 • [marketing@evapco.com](mailto:marketing@evapco.com) • [evapco.com](http://evapco.com)

©2024 EVAPCO, Inc.



Printed on recycled paper  
using soy-based ink