

# EVAPCO, INC.



|                                      |                     |       |                             |           |                   |          |
|--------------------------------------|---------------------|-------|-----------------------------|-----------|-------------------|----------|
| UNIT<br><b>EVAPORATIVE CONDENSER</b> | MODEL #<br>PHC-L683 | SCALE | DWG. #<br>HCS1224S12-DRC-ST | REV.<br>- | DATE<br>11/2/2024 | SERIAL # |
|--------------------------------------|---------------------|-------|-----------------------------|-----------|-------------------|----------|

**NOTES:**

- (M)- FAN MOTOR LOCATION
- HEAVIEST SECTION IS UPPER SECTION
- MPT DENOTES MALE PIPE THREAD  
FPT DENOTES FEMALE PIPE THREAD  
BFW DENOTES BEVELED FOR WELDING  
GVD DENOTES GROOVED
- +UNIT WEIGHT DOES NOT INCLUDE ACCESSORIES (SEE ACCESSORY DRAWINGS)
- MAKE-UP WATER PRESSURE  
20 psi MIN [137 kPa], 50 psi MAX [344 kPa]
- 3/4" DIA. MOUNTING HOLES. REFER TO RECOMMENDED STEEL SUPPORT DRAWING.
- \*- APPROXIMATE DIMENSIONS DO NOT USE FOR PRE-FABRICATION OF CONNECTION PIPING.
- \*\*-UNITS WITH 20HP PER FAN REQUIRE A TALLER FAN CYLINDER, ADD 5" TO THESE DIMENSIONS.
- DIMENSIONS LISTED AS FOLLOWS: ENGLISH IN [METRIC] [mm]

**FACE 2  
PLAN VIEW**

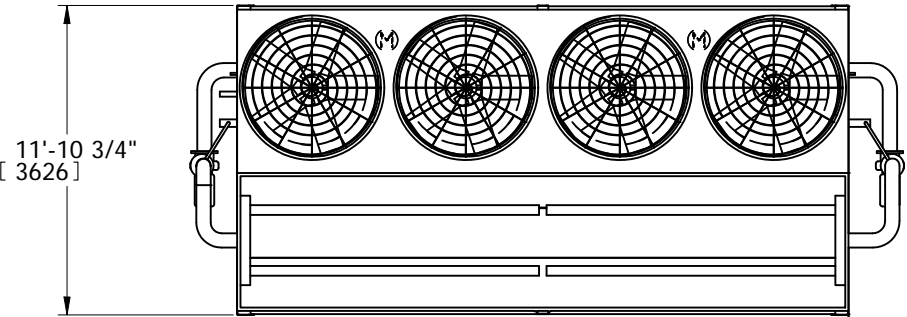

**FACE 1**

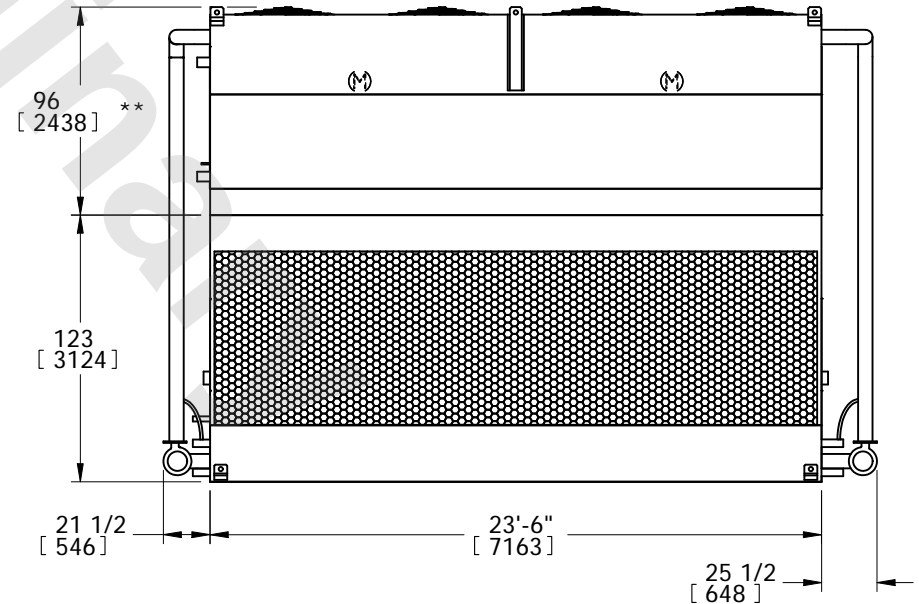
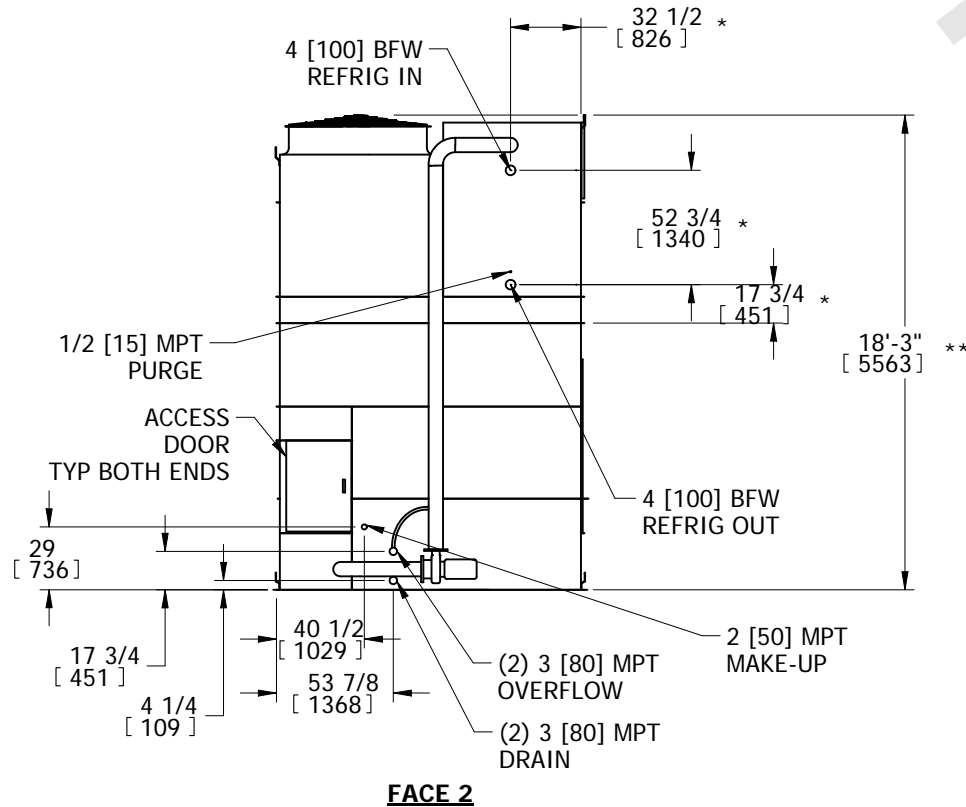

**FACE 1**

|   |  |  |                               |                  |
|---|--|--|-------------------------------|------------------|
| SHIPPING WEIGHT<br>27410 lbs+ [12435] kg+ | OPERATING WEIGHT<br>38290 lbs+ [17370] kg+ | HEAVIEST SECTION WEIGHT<br>18610 lbs+ [8445] kg+ | NO. OF SHIPPING SECTIONS<br>2 | DRAWN BY:<br>TLS |
|---|--|--|-------------------------------|------------------|