



Rigging & Assembly Instructions

AT

INDUCED DRAFT
COUNTERFLOW
COOLING TOWERS



Mr. GoodTower®



BULLETIN AT24RIG

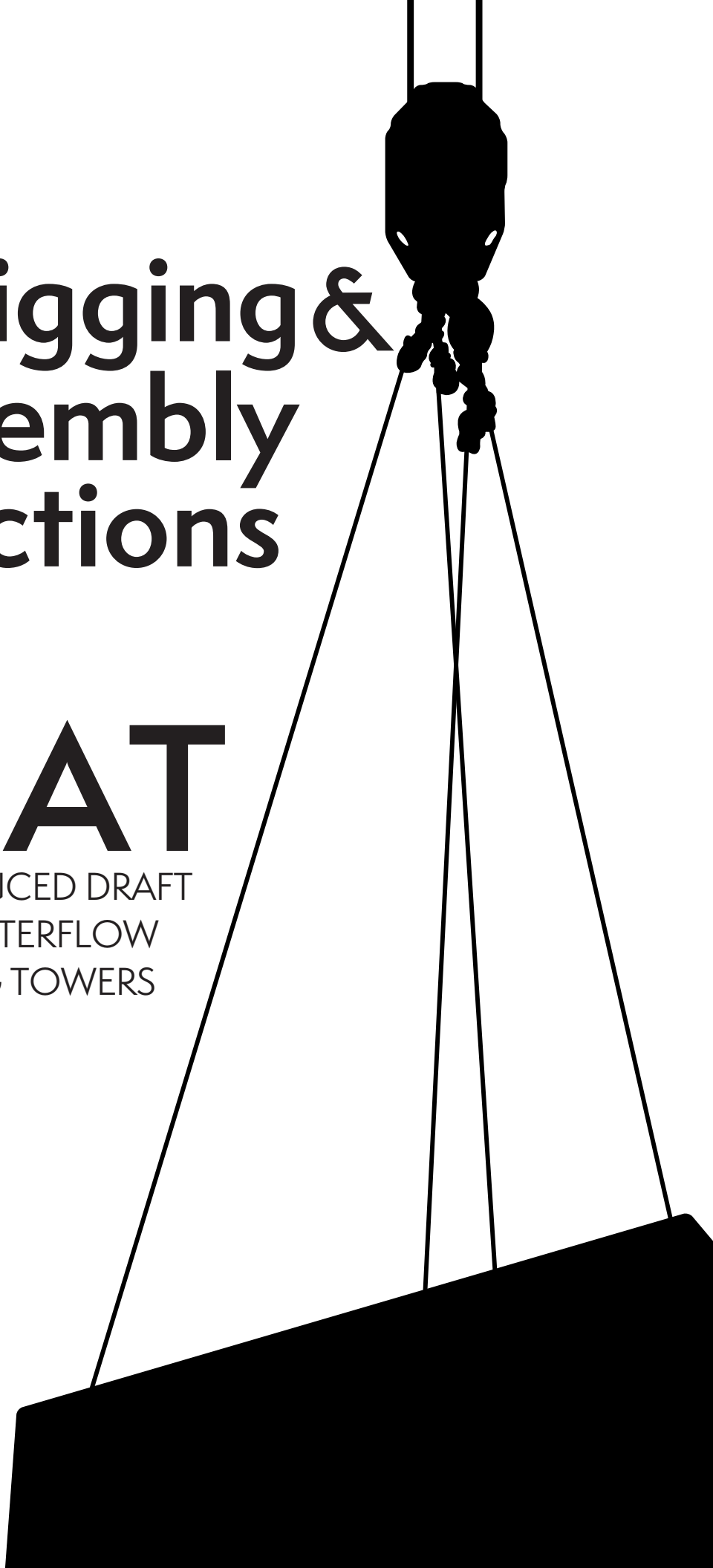



Table of Contents

Introduction	1
Shipping.....	1
Nomenclature	1
Structural Steel Support	2
Rigging Bottom Sections.....	3
Joining Multi-Cell Units Bottom Sections	6
Equalizer Blank-Off Plate: Multi Cell Units.....	8
Application of Sealer Tape.....	8
Rigging Upper Sections.....	9
Extended Lifts.....	10
3-Section Shipments.....	10
Casing Section Rigging	10
Fan Section Rigging.....	11
Assembly of the Upper Section to the Bottom Section	12
Using Drift Pins for Final Positioning	12
Containerized Unit Assembly.....	14
Installing Watertight Partitions & Firewalls.....	17
Rigging Fully Assembled Units	18
External Motor Installation – Belt Drive.....	19
Optional Motor & Gear Box Davit Installation.....	20
External Motor Installation – Gear Drive.....	20
Floating Shaft Installation & Alignment	21
Mounting Fan Screens	22
Sloped Ladder Installation	24
External Platform and Vertical Ladder Installation.....	26
External Platform and Vertical Ladder Installation Continued.....	27
ASME Flange Pattern Sealing Instructions	28
Field Assembly of Bottom Inlet.....	29
Appendix A.....	30
Notes	31

The AT INDUCED DRAFT COUNTERFLOW COOLING TOWERS should be rigged and assembled using the instructions and recommendations outlined in this bulletin.

All personnel should review these procedures, as well as the latest industry-approved installation practices, prior to rigging and assembly. The information in this bulletin is for informational purposes only. These instructions do not purport to cover all variations and possible contingencies in connection with installation. Additionally, the procedures described therein are subject to change without prior notice, due to EVAPCO, Inc.'s ongoing research and development.

EVAPCO, Inc. makes no representations or warranties with respect to these instructions or the products described herein. Nor shall EVAPCO, Inc. be responsible for any loss or damage (direct, indirect, consequential, or other) during installation or handling of equipment after shipment.

For a full description of EVAPCO's liability policy, please visit www.evapco.com to access our Terms and Conditions.

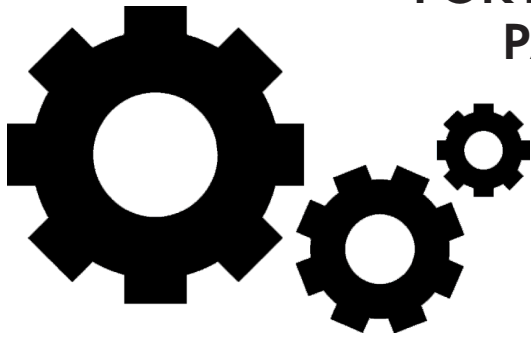

**FOR EVAPCO AUTHORIZED
PARTS AND SERVICE,
CONTACT YOUR
LOCAL EVAPCO
REPRESENTATIVE
OR THE LOCAL
SERVICE CENTER**



Mr. GoodTower®



EVAPCO, Inc. — World Headquarters & Research / Development Center

P.O. Box 1300 • Westminster, MD 21158 USA
410.756.2600 • marketing@evapco.com • evapco.com

North America

**EVAPCO, Inc.
World Headquarters**
Westminster, MD USA
410.756.2600
marketing@evapco.com

EVAPCO East
Taneytown, MD USA

EVAPCO East
Key Building
Taneytown, MD USA

EVAPCO Midwest
Greenup, IL USA
217.923.3431
evapcomw@evapcomw.com

Evapcold Manufacturing
Greenup, IL USA

EVAPCO West
Madera, CA USA
559.673.2207
contact@evapcowest.com

EVAPCO Alcoil, Inc.
York, PA USA
717.347.7500
info@evapco-alcoil.com

EVAPCO Iowa
Lake View, IA USA

EVAPCO Iowa
Sales & Engineering
Medford, MN USA
507.446.8005
evapcomn@evapcomn.com

EVAPCO LMP ULC
Laval, Quebec, Canada
450.629.9864
info@evapcolmp.ca

EVAPCO Select Technologies, Inc.
Belmont, MI USA
844.785.9506
emarketing@evapcoselect.com

**Refrigeration Vessels &
Systems Corporation**
Bryan, TX USA
979.778.0095
rvs@rvscorp.com

Tower Components, Inc.
Ramseur, NC USA
336.824.2102
mail@towercomponentsinc.com

EvapTech, Inc.
Edwardsville, KS USA
913.322.5165
marketing@evaptech.com

EVAPCO Dry Cooling, Inc.
Bridgewater, NJ USA
908.379.2665
info@evapcodc.com

EVAPCO Dry Cooling, Inc.
Littleton, CO USA
908.895.3236
info@evapcodc.com

EVAPCO Power México S. de R.L. de C.V.
Mexico City, Mexico
(52) 55.8421.9260
info@evapcodc.com

Asia Pacific

**EVAPCO Asia Pacific
Headquarters**
Baoshan Industrial Zone Shanghai, P.R. China
(86) 21.6687.7786
marketing@evapcochina.com

**EVAPCO (Shanghai)
Refrigeration Equipment Co., Ltd.**
Baoshan Industrial Zone, Shanghai, P.R. China

**EVAPCO (Beijing)
Refrigeration Equipment Co., Ltd.**
Huairou District, Beijing, P.R. China
(86) 10.6166.7238
marketing@evapcochina.com

**EVAPCO Air Cooling Systems
(Jiaxing) Company, Ltd.**
Jiaxing, Zhejiang, P.R. China
(86) 573.8311.9379
info@evapcochina.com

EVAPCO Australia (Pty.) Ltd.
Riverstone, NSW, Australia
(61) 02.9627.3322
sales@evapco.com.au

**EvapTech (Shanghai)
Cooling Tower Co., Ltd**
Baoshan District, Shanghai, P.R. China.
Tel: (86) 21.6478.0265

EvapTech Asia Pacific Sdn. Bhd.
Puchong, Selangor, Malaysia
(60) 3.8070.7255
marketing-ap@evaptech.com

Europe | Middle East | Africa

**EVAPCO Europe
EMENA Headquarters**
Tongeren, Belgium
(32) 12.39.50.29
evapco.europe@evapco.be

EVAPCO Europe BV
Tongeren, Belgium

EVAPCO Europe, S.r.l.
Milan, Italy
(39) 02.939.9041
evapcoeuropa@evapco.it

EVAPCO Europe, S.r.l.
Sondrio, Italy

EVAPCO Europe A/S
Aabybro, Denmark
(45) 9824.4999
info@evapco.dk

EVAPCO Europe GmbH
Meerbusch, Germany
(49) 2159.69560
info@evapco.de

EVAPCO Middle East DMCC
Dubai, United Arab Emirates
(971) 56.991.6584
info@evapco.ae

Evap Egypt Engineering Industries Co.
A licensed manufacturer of EVAPCO, Inc.
Nasr City, Cairo, Egypt
(20) 10.054.32.198
evapco@tiba-group.com

EVAPCO S.A. (Pty.) Ltd.
A licensed manufacturer of EVAPCO, Inc.
Isando, South Africa
(27) 11.392.6630
evapco@evapco.co.za

South America

EVAPCO Brasil
Equipamentos Industriais Ltda.
Indaiatuba, São Paulo, Brazil
(55) 11.5681.2000
vendas@evapco.com.br

FanTR Technology Resources
Itu, São Paulo, Brazil
(55) 11.4025.1670
fantr@fantr.com

TECHNOLOGY FOR THE FUTURE, AVAILABLE TODAY
Visit EVAPCO's website: evapco.com



Introduction

Thank you for purchasing your EVAPCO AT induced draft, counterflow cooling tower. This manual provides instructions and recommendations to safely and correctly install all AT cooling towers. It is recommended that all the instructions provided in this manual be reviewed in detail prior to rigging and assembly. If at any point, specific circumstances not covered by this manual arise, please contact your local EVAPCO representative for assistance.

Proper care must be taken by all parties involved in handling and assembling the equipment to ensure that safe and thorough installation practices are implemented to prevent damage or injury to the equipment, persons and environment involved.

Shipping

Unless otherwise noted in the factory submittal, all EVAPCO AT towers ship in two (2) sections per cell (upper and lower). In some cases, units are shipped completely knocked down, in three (3) sections per cell, or one (1) section per cell. Any special shipping configurations will be listed in the factory submittal. Please contact your local EVAPCO representative for more information on alternate shipping configurations.

Nomenclature

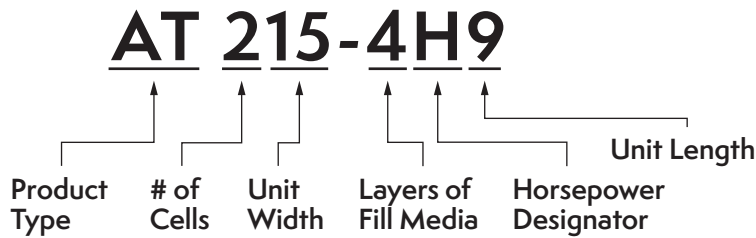

Product Type

AT – Indicates an Advanced Technology (AT) tower

of Cells

Determined by the number of inlet connections, can be 1, 2, 3, or 4

Unit Width

The total width of the unit, in feet, all cells included. This value is rounded to the closest whole number

Layers of Fill Media

Determined by the number of 1-foot-tall fill layers. Can be 2, 3, 4, or 5

Horsepower Designator

Determined by the horsepower per fan motor. Available from E = 2 HP to R = 100 HP

Unit Length

The total length of the unit, in feet, all cells included. This value is rounded to the closest whole number

Structural Steel Support

Two structural I-beams running the length of the unit are required for support of each cell of the units. These beams should be located underneath the outer flanges of the unit (See **Table 1**). Mounting holes 3/4" (19mm) in diameter are located in the bottom flanges of the unit for bolting to the structural steel (See steel support print in unit submittal for exact bolt hole location). Bolt the bottom section to the steel support before rigging the top section.

Beams should be sized in accordance with accepted structural practices. Maximum deflection of the beam under the unit to be 1/360th of the unit length, not to exceed 1/2" (13mm). Deflection may be calculated by using 55% of the operating weight of the unit as a uniform load on each beam (See certified print in unit submittal for operating weight).

The supporting I-beams should be level before setting the unit. Do not level the unit by shimming between the bottom flanges and the beams as this will not provide proper and continuous longitudinal support. Support beams and anchor bolts are to be furnished by others. Always refer to the certified print in the unit submittal for unit weights, dimensions and technical data.

Please refer to the unit submittal for detailed, project specific steel support arrangement.

<p>4' (1.2m), 7' (2.24m), 8' (2.4m), 8.5' (2.6m), 10' (3m), 12' (3.6m) and 14' (4.3m) wide single & multi-cell units</p>	
<p>14' (4.3m), 15' (4.6m), 16' (4.8m), 17' (5.2m), 20' (6m), 24' (7.3) and 28' (8.6m) wide multi-cell units</p> <p>*6x17, 8x17 and 12x8.5 cooling towers will use this steel arrangement</p>	
<p>42' (12.8m) wide multi-cell units</p>	
<p>56' (17.2m) wide multi-cell units</p>	

Table 1 – Standard Longitudinal Steel Support Arrangement



Rigging Bottom Sections

Lifting devices are located along the inside corners of the bottom section for lifting and final positioning purposes as shown in **Figures 1a through 1d**. The hook of the crane must be a minimum dimension of "H" above the lifting devices to prevent undue strain on the lifting devices. See **Table 2** for the minimum "H" dimension. These lifting devices should not be used for extended lifts or where any hazard exists unless safety slings are employed under the section. See "Extended Lifts" on page 10 for proper arrangement. The unit must be lifted from all lifting devices provided in the section, consult **Table 2** for number of devices per box size.

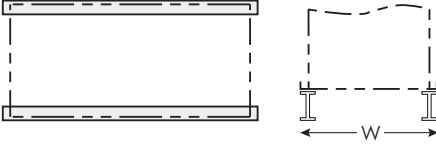
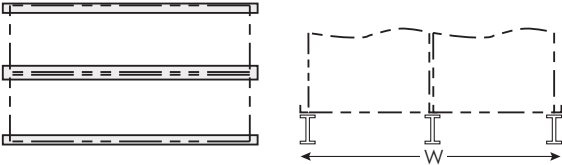
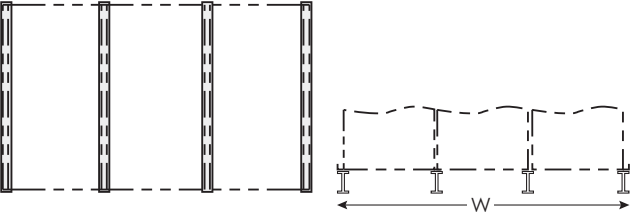
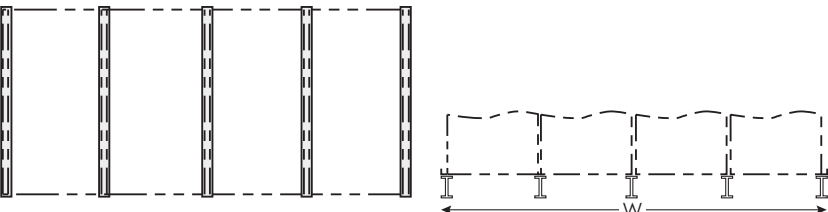
Bolt the bottom section to the steel support before rigging the top section.

Section Width		Section Length		Minimum "H" Dimension		Number of Lifting Devices
Feet	Meters	Feet	Meters	Feet	Meters	Number
4	1.2	4	1.2	5	1.5	4
		6	1.8	5	1.5	4
		9	2.7	9	2.7	4
		12	3.6	11	3.4	4
6	1.8	8.5	2.6	9	2.7	4
7	2.24	9	2.7	10	3	4
		12	3.6	12	3.7	4
		18	5.5	19	5.8	4
8/8.5	2.4/2.6	7.5	2.4	10	3	4
		9	2.7	10	3	4
		10.5	3.2	11	3.4	4
		12	3.6	12	3.7	4
		14	4.3	15	4.6	4
		18	5.5	19	5.8	4
10	3	21	6.4	22	6.7	4
		12	3.6	15	4.6	4
12	3.6	18	5.5	19	5.8	4
		12	3.6	15	4.6	4
		14	4.3	17	5.2	4
		18	5.5	19	5.8	4
		20	6	21	6.4	4
		24	7.3	24	7.3	8
		28	8.5	27	8.2	8
		36	11	33	10.1	8
14	4.3	40	12.2	37	11.3	8
		18	5.5	19	5.8	4
		24	7.3	21	5.2	6
		26	7.8	22	6.7	6

Table 2 – Minimum "H" Dimension when Lifting Bottom Sections

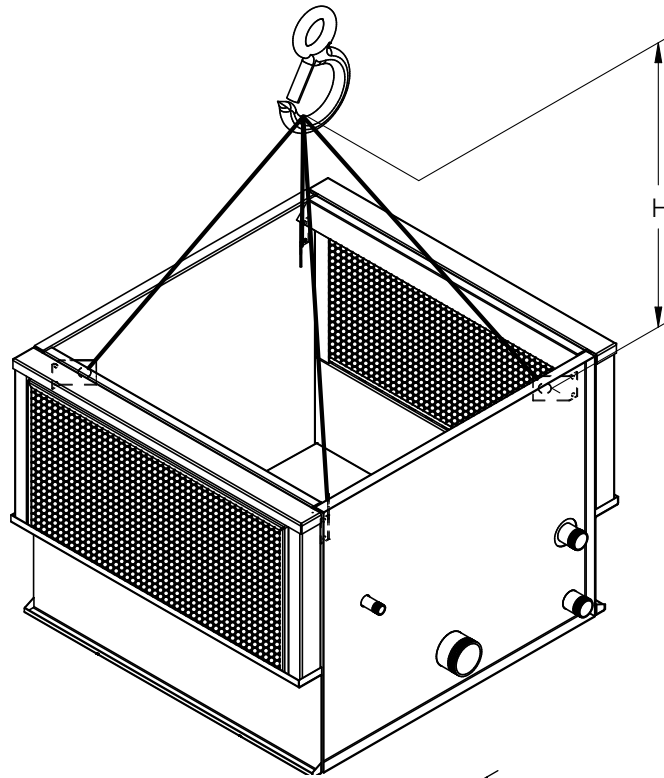

Figure 1a – 4' (1.2m) Wide Unit Bottom Section

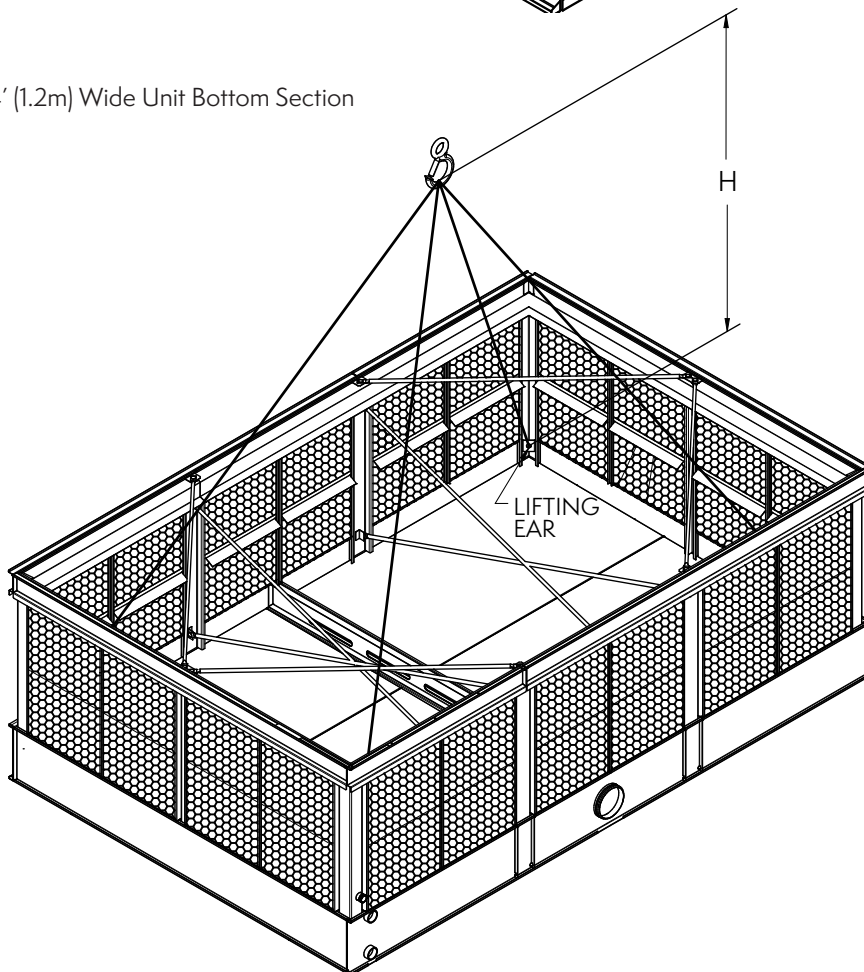

Figure 1b – 12' (3.6m) Wide Unit Bottom Section

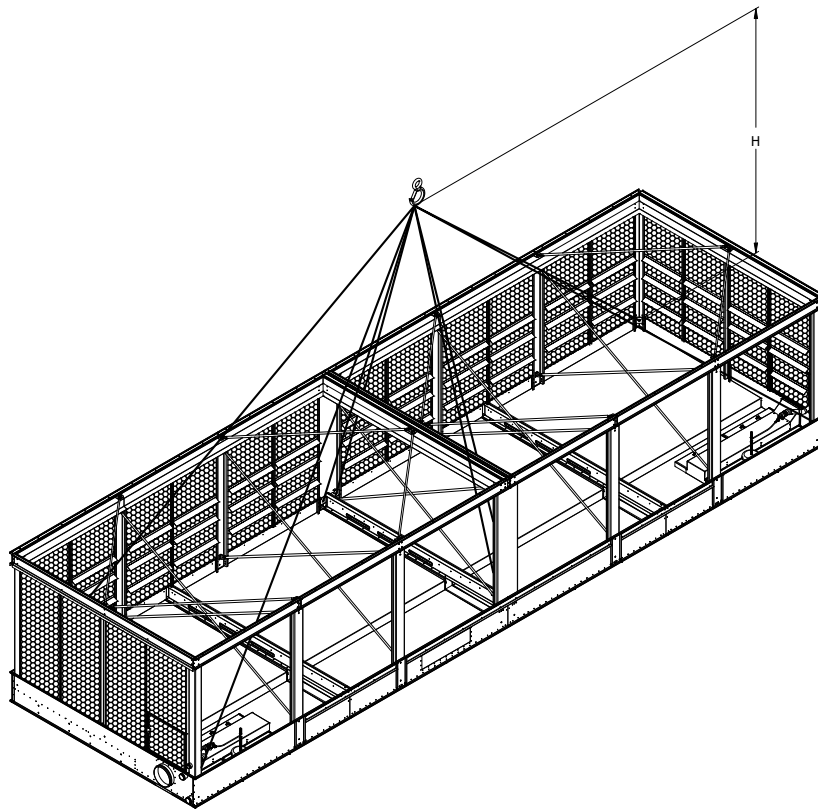

Figure 1c – 12'x24' (3.7 m x 12.2 m) through 40 bottom section

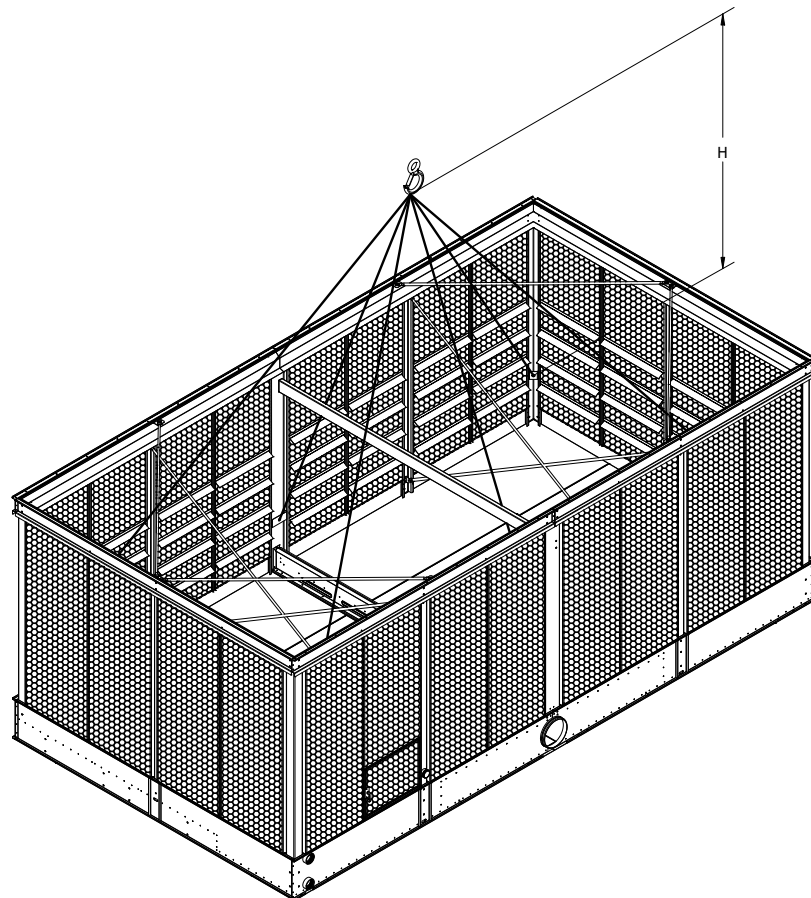

Figure 1d – 14x (4.3 m) wide bottom section

Joining Multi-Cell Units Bottom Sections

On all 2-cell models, the two bottom sections are shipped separately and are typically furnished with a connecting equalizer flume box between them. On all 3-cell models, the three bottom sections are shipped separately and are typically furnished with two connecting equalizer flumes between them.

In addition to the equalizer flumes, these units are provided with horizontal drip channels and vertical splash guards to keep water from splashing out from between the cells. All units have one or more horizontal drip channels and two vertical splash guards per flume box.

Flume boxes are a standard offering on multi-cell units. Multi-cell units are also available with external equalizer connections, which can be connected by field installed piping. **The flume box(es) will be deleted when external equalizer connections are provided.**

For units on which the flume box ships loose:

1. Rig one of the bottom sections of the multi-cell cooling tower. Bolt to steel support.
2. One face of the flume box is provided with 3/8" (10mm) welded bolts. Clean the mating flume opening on the rigged bottom section and apply a layer of sealer tape on this surface, centered between the hole centers and the outside edge. Remove paper backing strip from sealer tape.
3. Align the bolt holes in the rigged bottom section with the welded 3/8" (10mm) bolts on the flume box.
4. Install 3/8" (10mm) nuts and washers on every bolt around the flume opening and tighten.
5. Follow steps 4 through 12 as shown below.

For units on which the flume box ships mounted to one cell:

1. Install the bottom section with the factory installed flume box on it as described above.
2. Clean the flanges on the flume box on the end to be field connected. Apply a layer of sealer tape on the flange, centered between the hole centers and the outside edge. Remove paper backing strip from the sealer tape.
3. Clean the mating surface of the flume opening of any dirt, grease, or moisture.
4. Rig the second bottom section adjacent to the equalizer flume on the steel support as shown in the sequential figures that follow.
5. Align the bolt holes in the flume box and flume opening with drift pins (by others) while drawing the second bottom section against the flanged connection.
6. Install 3/8" (10mm) bolts, nuts, and washers in every hole around the flume opening and tighten.
7. Bolt the second bottom section to the steel support.
8. Remove the 1/4" (6mm) bolts which hold the drip channel retaining clips to the panel. Place the drip channel over the adjoining panel section flanges. Turn around the retaining clips and install them using the same hardware.
9. If there are multiple drip channels, apply sealer tape as shown in **Figure 2b**, fasten them together end-to-end by driving a self-tapping 5/16" (8mm) screw through the section end with the larger hole into the mating end with the smaller hole. Stainless steel units will use 5/16" (8mm) stainless steel nuts and bolts.
10. Place the vertical splash guard in the bend of the vertical supports. On galvanized units, attach the vertical splash guard using 5/16" (8mm) self-tapping screws. On stainless steel units, attach the vertical splash guards using 5/16" (8mm) stainless steel nuts and bolts. (See **Figure 2b**)
11. Attach the bottom of the vertical splash guard to the drip channel using 5/16" (8mm) hardware and sealer tape as shown in **Figure 2b**.
12. This step only applies to units with a 5-1/8" (130mm) spacing between cells. Place the filler cap channel in the upper flanges of the bottom section as shown in **Figure 2b**. Attach to vertical splash guards using 5/16" (8mm) tappers (for galvanized units) or stainless steel nuts and bolts (for stainless steel units)

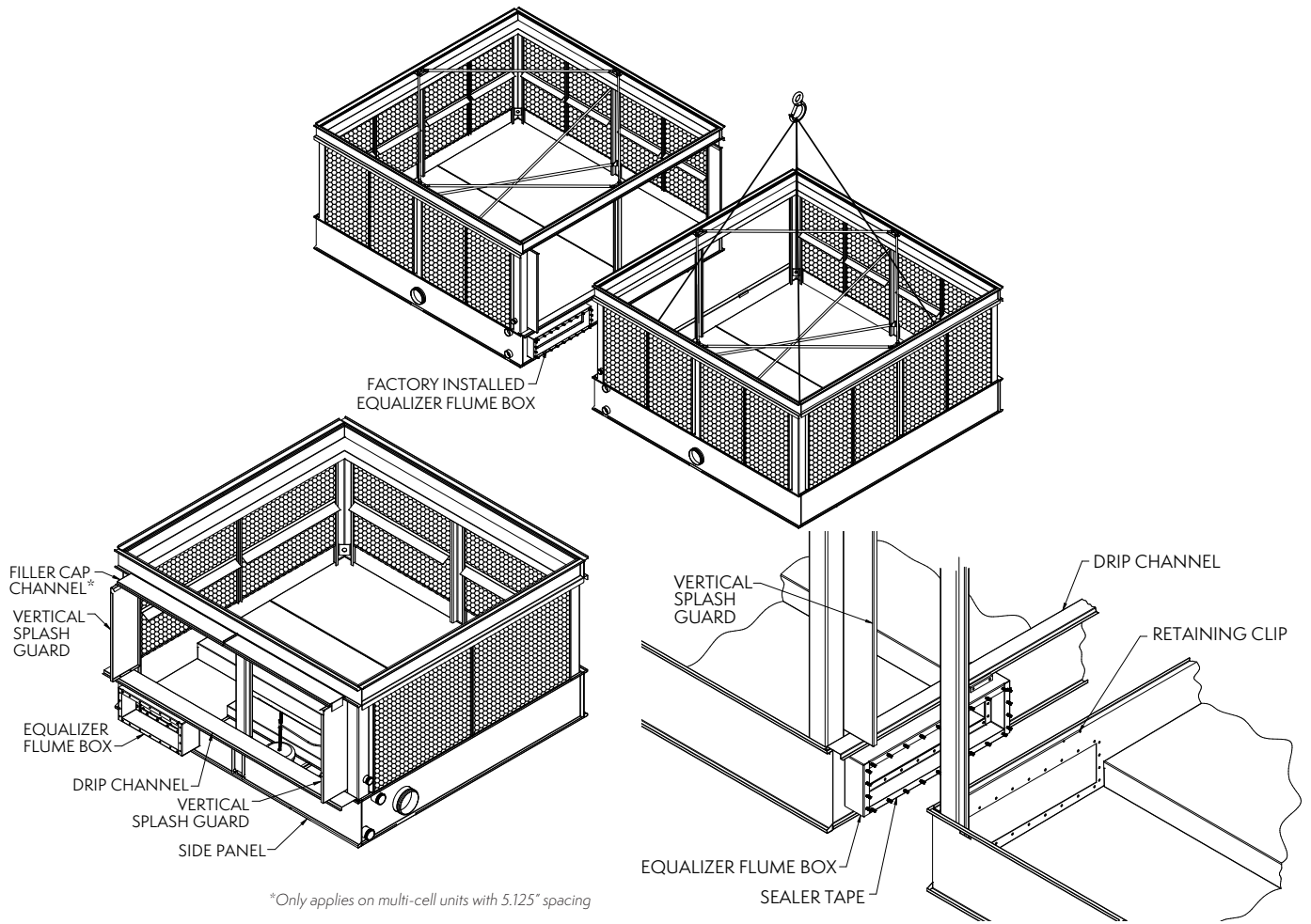

Figure 2a – Joining Bottom Sections on Multi-Cell Units

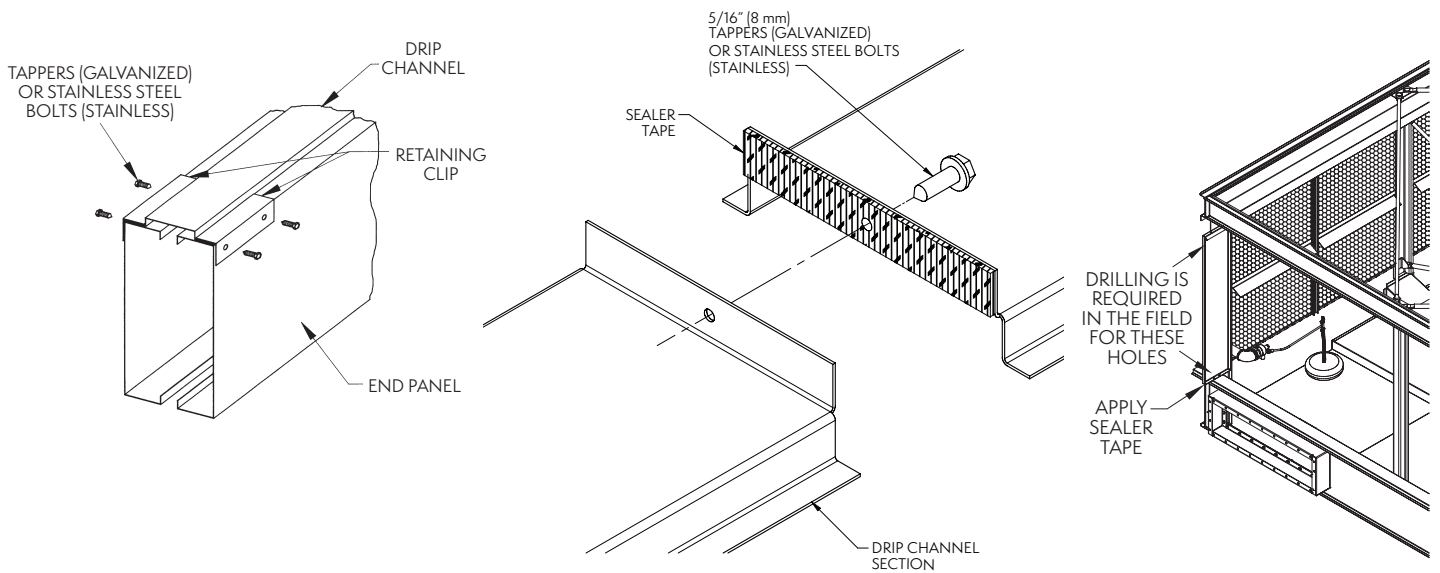

Figure 2b – Drip Channel and Vertical Splash Guard Installation

Equalizer Blank-Off Plate: Multi Cell Units

Equalizer blank-off plate(s) are available to isolate the bottom sections for individual cell operation, periodic cleaning, or maintenance. The optional equalizer blank-off plate is factory installed on the equalizer flume and secured by wing nuts. This plate is also known as a “flume plate” or “positive closure plate.”

For units not requiring the blank-off plate under normal operating conditions, remove the wing nuts, washers, plate and gasket. Reinstall washers and wing nuts for proper leak free operation of the equalizer flume box.

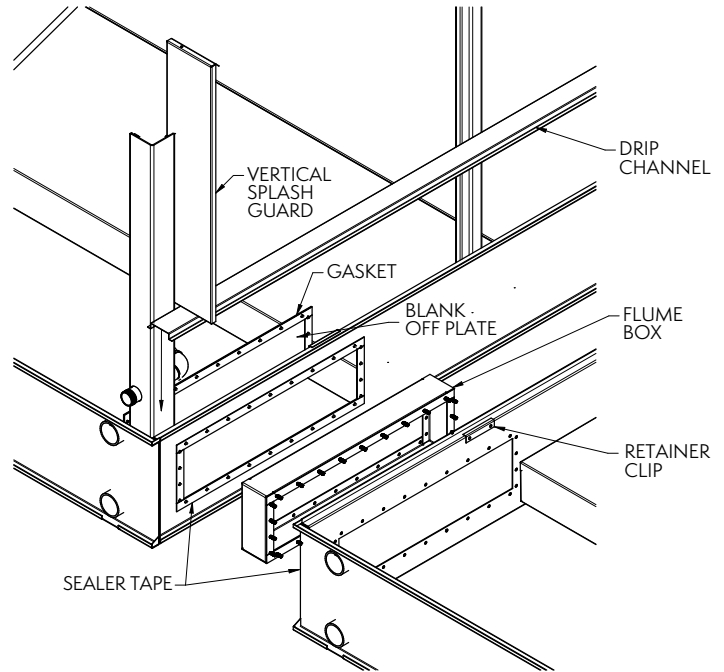

Figure 3 – Equalizer Blank-Off Plate Installation

Application of Sealer Tape

Once the bottom section has been set on the supporting steel and bolted in place, the top flanges should be wiped down to remove any dirt or moisture. Sealer tape should be placed over the mounting hole centerline on the side flanges along the entire length of all sides. Apply two strips of sealer tape, one partially overlapping the other, on the entire length of the end flanges (flanges with no bolt holes).

The sealer tape **should overlap on the corners** as shown in **Figure 4a**. Do not splice the sealer tape along the end flanges and preferably not on the side flanges if it can be avoided.

Always remove the paper backing from the sealer tape.

All models with two or more top sections must have sealer tape applied along the entire length of all internal flanges, as shown in **Figure 4b**.

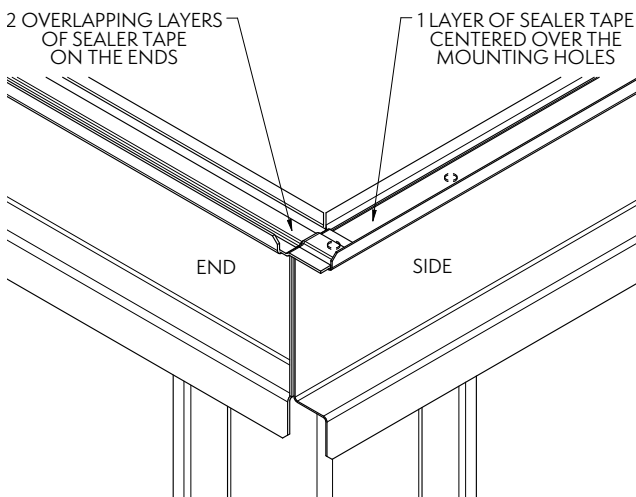

Figure 4a – Sealer Tape on Flange of Bottom Section

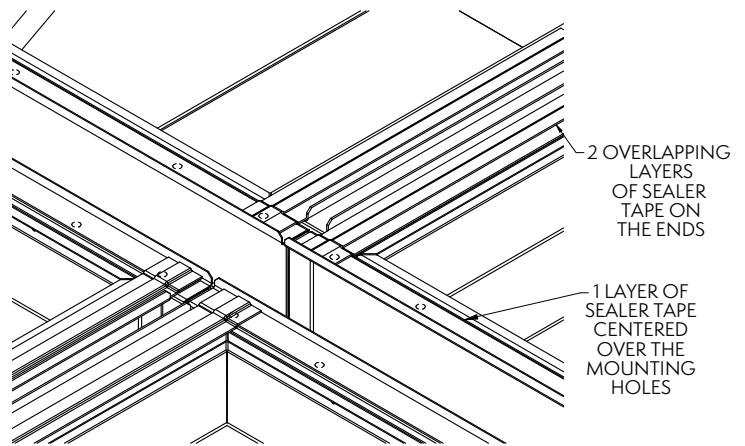

Figure 4b – Sealer Tape Detail for Center Joint of Units with Four Top Sections

Rigging Upper Sections

U-bolts are provided in the corners of the top section for lifting and final positioning. The hook of the crane must be a minimum dimension "H" above the top section being lifted to prevent undue strain on the U-bolts. See **Table 3** below for the minimum "H" dimension. These lifting devices should not be used for extended lifts or where any hazard exists unless safety slings are employed under the section. See "Extended Lifts" on page 10 for proper arrangement. The unit must be lifted from all lifting devices provided in the section, consult **Table 3** for number of devices per box size.

Section Width		Section Length		Minimum "H" Dimension		Number of Lifting Devices
Feet	Meters	Feet	Meters	Feet	Meters	
4	1.2	4	1.2	5	1.5	4
		6	1.8	6	1.8	4
		9	2.7	8	2.4	4
		12	3.6	11	3.4	4
6	1.8	8.5	2.6	9	2.7	4
7	2.24	9	2.7	9	2.7	4
		12	3.6	10	3	4
		18	5.5	14	4.3	8
8/8.5	2.4/2.6	6	1.8	7	2.1	4
		7.5	2.4	8	2.4	4
		9	2.7	9	2.7	4
		10.5	3.2	10	3	4
		12	3.6	10	3	4
		14	4.3	12	3.6	4
		18	5.5	14	4.3	8
10	3	12	3.6	12	3.6	4
		18	5.5	14	4.3	4
12	3.6	12	3.6	12	3.6	4
		14	4.3	13	4	4
		18	5.5	14	4.3	4
		20	6	15	4.6	4
14	4.3	18	5.5	14	4.3	4
		24	7.3	17	5.2	4
		26	7.8	22	6.7	8

Table 3 – Minimum "H" Dimension when Lifting Upper Sections

For units that ship in 3 sections per cell, refer to 3-section shipment section on page 10.

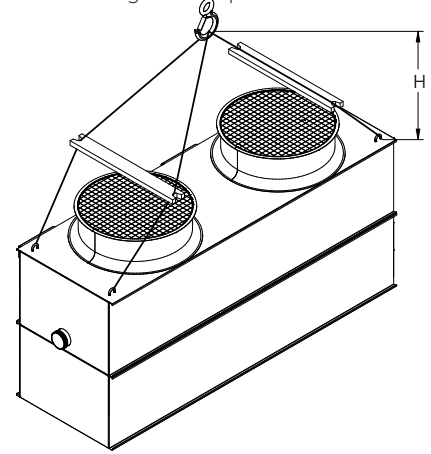

Figure 5a – 4' (1.2m) Wide Two-Fan Unit Upper Section

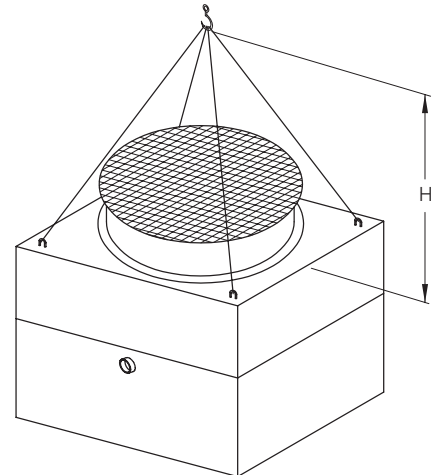

Figure 5b – 10' (3m) Wide Unit Upper Section

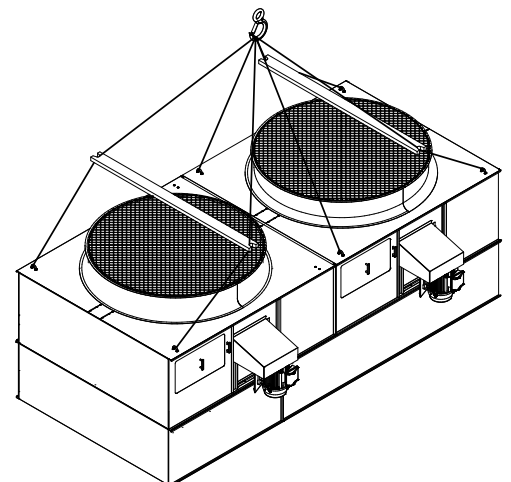

Figure 5c – 8.5' (2.6m) Wide Two-Fan Unit Upper Section

Extended Lifts

NOTE: The lifting devices and U-bolts should be used for final positioning only and for lifting where no danger exists. If they are used for extended lifts, safety slings should be provided under the sections.

Safety slings and skids must be removed before final positioning of the unit.

The preferred method for extended lifts is to use slings under the unit, as shown in **Figure 6** below. Spreader bars should always be used between the cables at the top of the section to prevent damage to the upper flanges or fan cylinders.

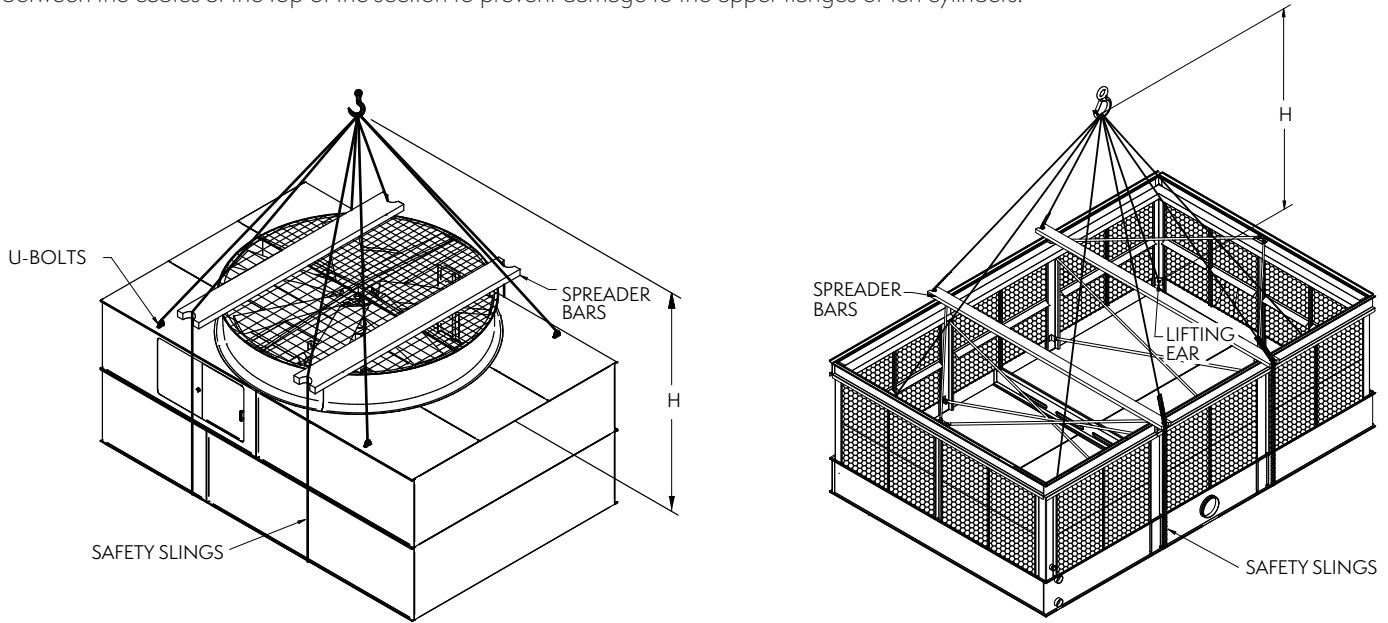

Figure 6 – Extended Lifts

3-Section Shipments

In some cases, a unit is shipped in 3 sections (Fan, Casing and Basin) in lieu of the standard 2 sections (Fan + Casing, and Basin). This is often done to reduce the shipping weight of each individual section, which in turn may reduce the size of the crane required to rig the unit. 3-section shipments also apply to containerized units, which are often shipped in 3 sections in order to fit in a shipping container.

Casing Section Rigging

The unit must be lifted from all lifting devices provided in the section, consult **Table 4** for number of devices per box size.

Section Width		Section Length		Minimum "H" Dimension		Number of Lifting Devices
Feet	Meters	Feet	Meters	Feet	Meters	
10 or 12	3 or 3.6	12	3.6	12	3.6	4
12	3.6	14	4.3	14	4.3	4
10 or 12	3 or 3.6	18	5.5	17	5.2	4
12	3.6	20	6	18	5.5	4
14	4.3	18	5.5	17	5.2	4
14	4.3	24	7.3	17	5.2	6
14	4.3	26	7.8	22	6.7	6

Table 4 – Minimum "H" Dimension and number of devices for Lift of Tower Casing Sections

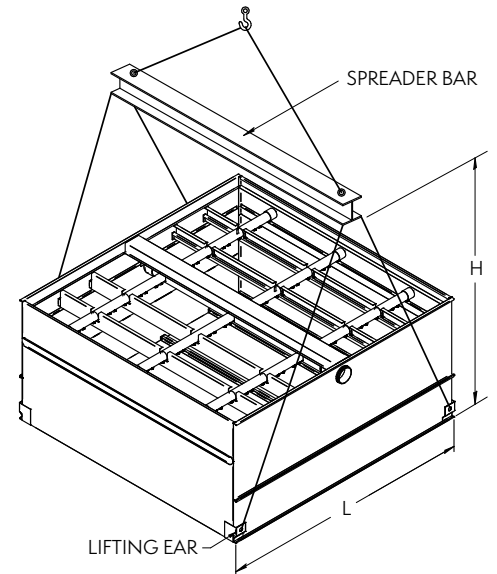

Figure 7a – Four-Point Rigging of Tower Casing Section with Added Lifting Ears



The 14' x 24' and 14' x 26' unit's casing sections will be provided with six lifting ears and should be rigged as a six-point lift as shown in **Figure 7b** below.

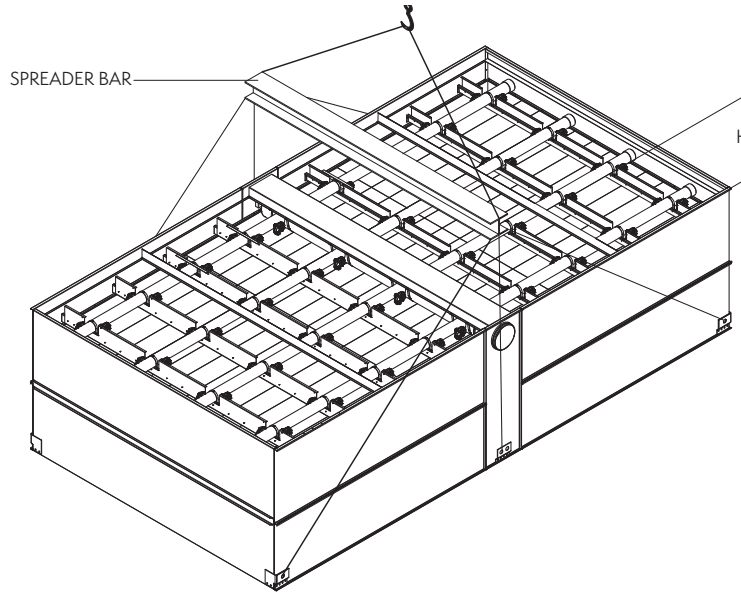

Figure 7b – Six-Point Rigging of 14' x 24' and 14' x 26' Tower Casing Section with Added Lifting Ears

Fan Section Rigging

NOTE: This section is only applicable for 10', 12' and 14' wide units. For all other box sizes reference Rigging Upper Sections on page 9.

When lifting the fan section separate from the casing section, the center of gravity of the fan section is heavily biased towards the location of the fan motor and major drive components. In order to avoid lifting the fan section at a lopsided angle, a three-point lift is necessary.

In such a case, an additional lifting ear is provided by the factory on the mechanical bearing support assembly. The U-bolts on the fan deck which are located close to the fan motor are removed.

Figure 8 shows the proper three-point lifting method for the fan section. The hook of the crane must be a minimum dimension "H" above the top of the section being lifted to prevent undue strain on the U-bolts. **Figure 9** shows the proper six-point lifting method for a 14' x 26' fan section.

See **Table 5** below for minimum "H" dimension to safely lift the fan section during a three-point or a six-point lift.

Section Length		Minimum "H" Standard Fan		Minimum "H" Dimension SLSF		Number of Lifting Dimension
Feet	Meters	Feet	Meters	Feet	Meters	Number
12	3.6	12	3.6	15	4.6	3
14	4.3	13	4	17	5.2	3
18	5.5	14	4.3	19	5.8	3
20	6	15	4.6	21	6.4	3
24	7.3	17	5.2	18	5.5	3
26	7.8	22	6.7	27	8.2	6

Table 5 – Minimum "H" Dimension for lift of Fan Sections

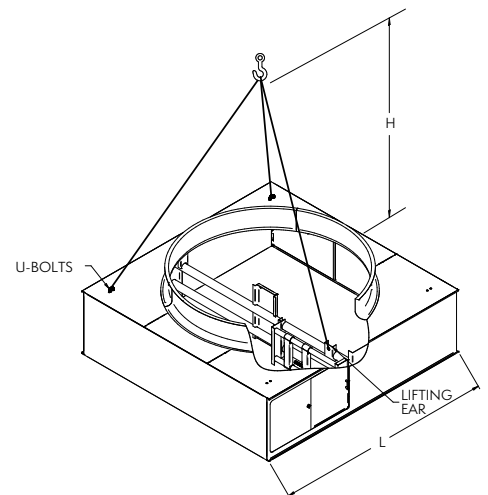

Figure 8 – Three-Point Lift

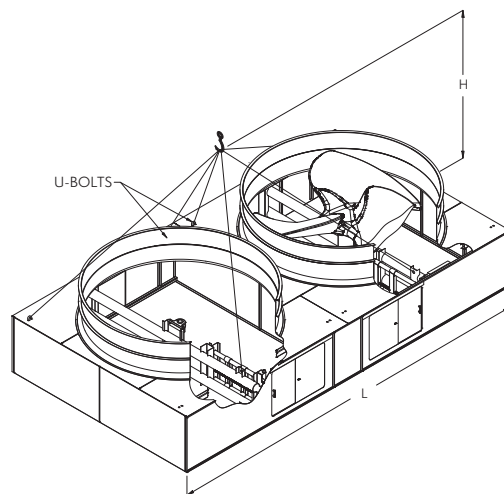

Figure 9 – Six-Point Lift 14' x 26' Fan Section

Prior to lowering the fan section onto the casing section, the side flanges on the casing sections must be cleaned by the installer and have sealer tape applied to them. The ends will need to be cleaned and have 2 overlapping layers of sealer tape applied to them. Follow instructions from the "Application of Sealer Tape" section of this manual.

Drift pins should be used to align the fan section with the casing section. The installer will need to attach the fan section *end panels* to the casing section *end panels* and the fan section *side panels* to the casing section *side panels* with self-threading tappers (galvanized units) or bolts (stainless units).

NOTE: Fan screen and fan screen support will be shipped loose in the event of a 3-section shipment. Both these items need to be installed after rigging.

Assembly of the Upper Section to the Bottom Section

Before securing the upper section to the bottom section, remove any loose parts shipped in the basin.

Wipe the flanges on the bottom of the upper section. Check to see that the water distribution connection on the top section is in the correct position relative to the bottom section (see unit certified drawing). Units are also provided with match markings on each section, as shown in Appendix A.

Lower the upper section to within several inches of the bottom section making sure the two sections do not touch and the sealer tape is not disturbed. Fasten all four corners. Make use of drift pins to simplify the fastening process.

Install the remaining fasteners, working from the corners towards the center. Fasteners must be installed in every hole in the side flanges. No fasteners are required on the end flanges.

Use of Drift Pins for Final Positioning

Drift pins are tools used to align holes in the flanges of the upper and lower sections of the unit prior to final fastening. By the time drift pins are needed, the lower section of the unit has already been anchored to its support structure. The sealer tape has been laid down on the lower section's flanges, and the upper section is now hovering over the lower section.

A drift pin should be driven into each of the corner bolt holes such that the upper and lower flanges are aligned as best as possible with sideways motion restricted.

On units which are longer than 12' ("L" > 12'), a drift pin should be used at an intermediate pair of bolt holes in the rigging seam to allow for proper alignment.

NOTES:

For multi-cell units, the side flanges located in between cells can be accessed from inside the unit.

Bolts can be driven upward through the mating flanges if access is restricted.

All rigging hardware is provided by EVAPCO. Drift pins are by others.

Units	Hardware Sizes
4' (1.2m) Wide Units	5/16" (8mm) Self-Tapping (If Galvanized) 5/16" (8mm) Nuts & Bolts (If Stainless)
All Others	3/8" (10mm) Nuts & Bolts (Galvanized or Stainless)

Table 6 – Hardware Sizes

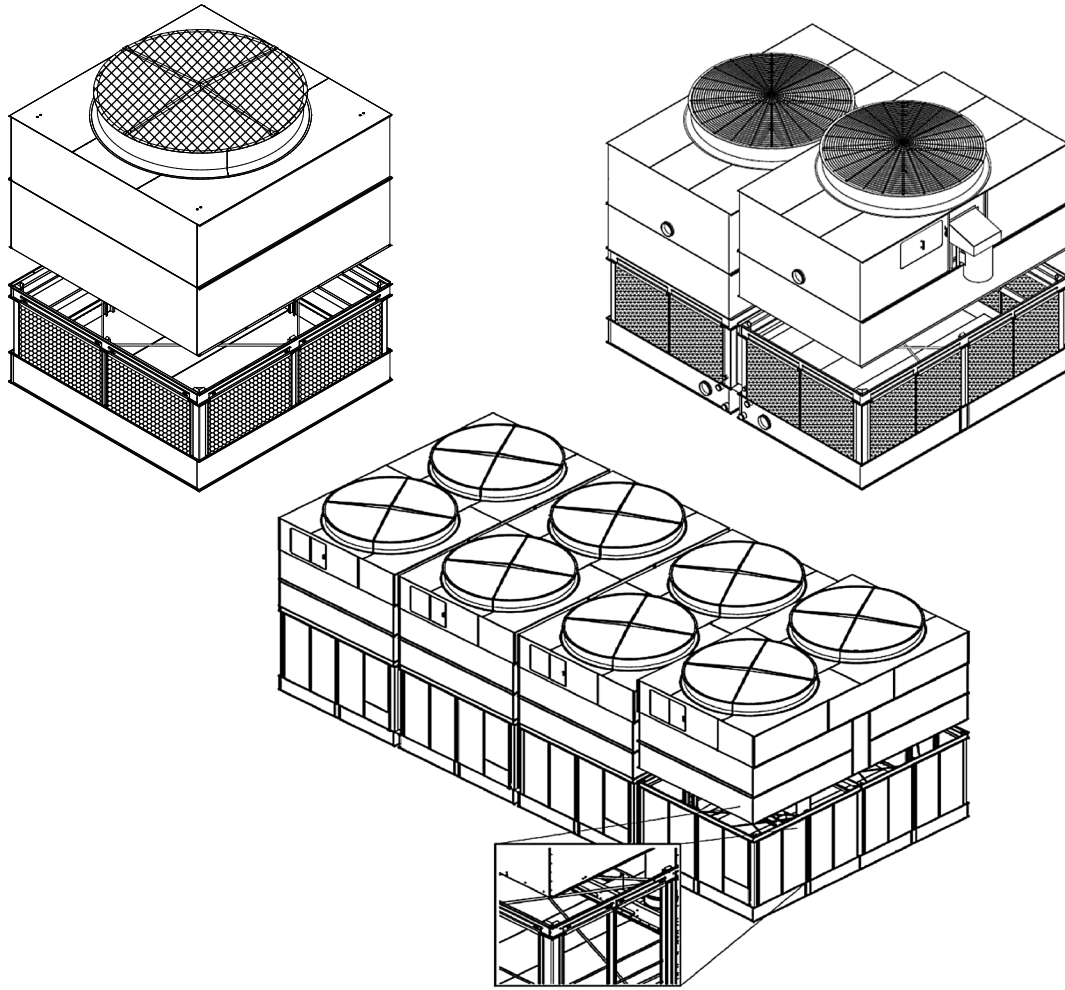

Figure 10 – Assembly of Upper Section to Bottom Section – Single & Multi-Cell Units

Containerized Unit Assembly

7' (2.24m) wide AT units are optimized to be transported in export containers for overseas shipment. Depending on the size of the unit and accessory options, there are a few different shipping configurations as outlined below in **Table 7**.

Configuration	Nominal Box Size	Standard Fan	Low Sound Fan	Super Low Sound Fan
Single Cell	7' x 9'	(1) 20'	(1) 20'	(1) 20'
	7' x 12'	(1) 40'	(1) 40'	(1) 40'
	7' x 14'	(1) 40' HC	(1) 40' HC	(1) 40' & (1) 20'
	7' x 18'	(1) 40' HC	(1) 40' & (1) 20'	(1) 40' & (1) 20'
Multi-Cell	14' x 9'	(1) 40' HC	(1) 40' & (1) 20'	(1) 40' & (1) 20'
	14' x 12'	(1) 40' HC & (1) 20'	(2) 40'	(2) 40'
	14' x 14'	(3) 40'	(3) 40'	(3) 40'
	14' x 18'	(3) 40' HC	(3) 40' HC	(3) 40' HC
	7' x 24'	(1) 40' HC & (1) 20'	(2) 40'	(2) 40'
	7' x 28'	(3) 40'	(3) 40'	(3) 40'
	7' x 36'	(3) 40'	(3) 40'	(3) 40'

Table 7 – Shipping Containers Required

NOTES:

- HC indicates “High Cube.” High cube containers provide an additional foot of container height
- Number of containers required based on standard unit. Any customizations or accessories could change number of containers required

Figure 11 below shows an example of a 7' x 18' unit shipping in a 40' high cube container. A high cube container is used so that the fan cylinders can ship mounted to the fan section. In such a case, the fan section is loosely bolted to the basin section.

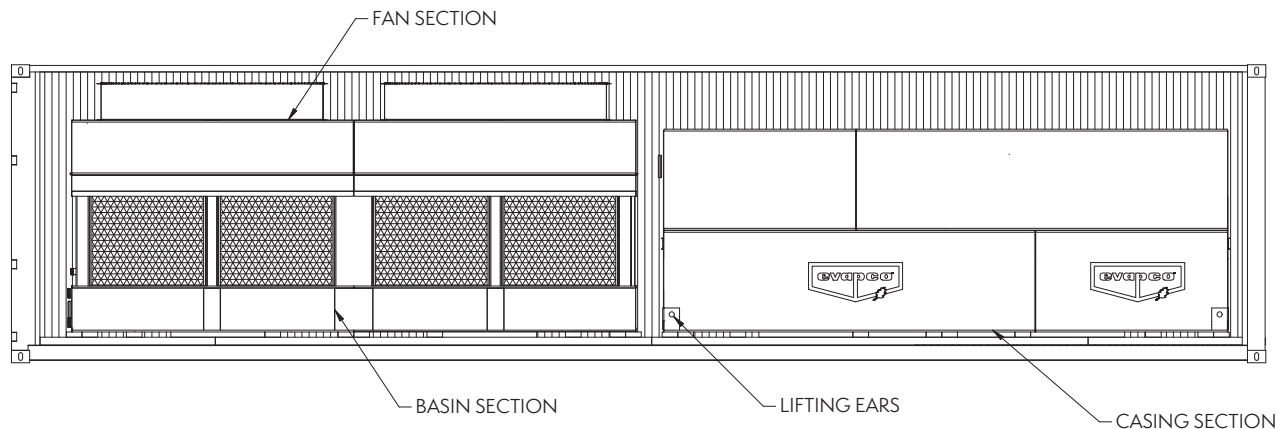

Figure 11 – 40' High Cube Container Shipment

Figure 12 shows a 7' x 9' unit shipping in a 20' standard height container. 20' containers are not available in high cube configuration, therefore fan cylinders are required to ship loose and be assembled in the field.

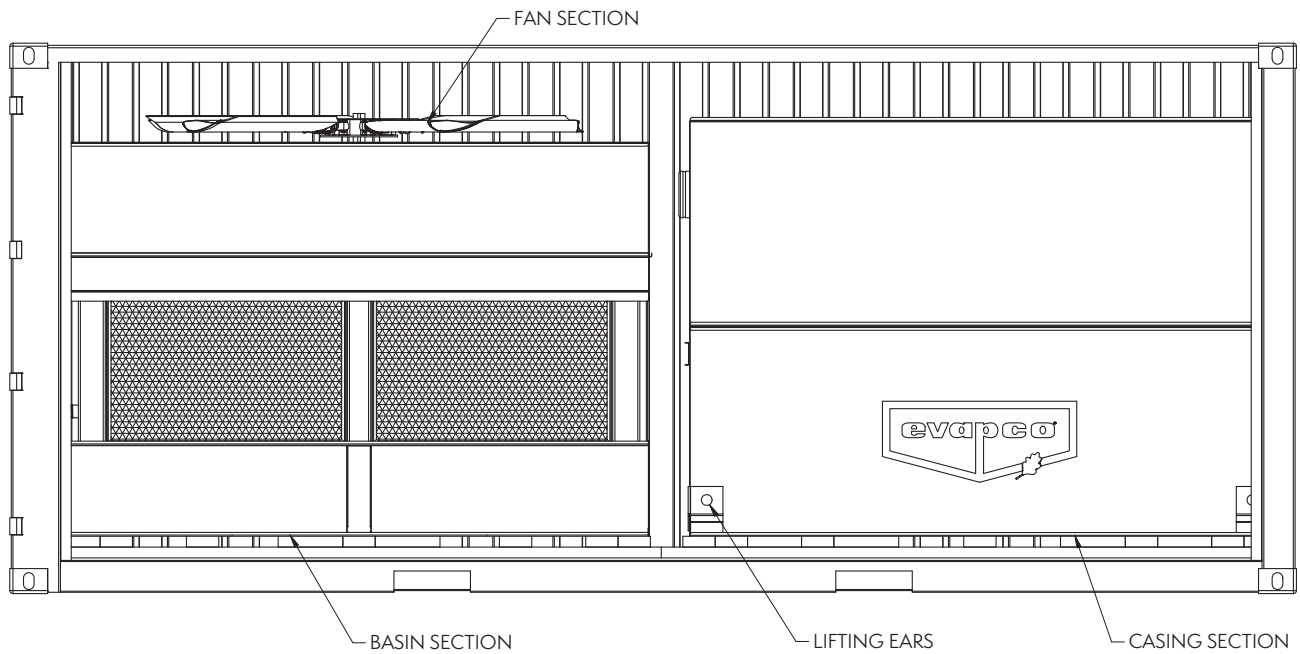

Figure 12 – 20' Standard Height Container Shipment

Instructions to put together fan cylinder:

1. Line up match-markings on the fan deck to ensure proper alignment if supplied.
2. Make sure fan assembly is centered within cylinder before attaching to fan section.

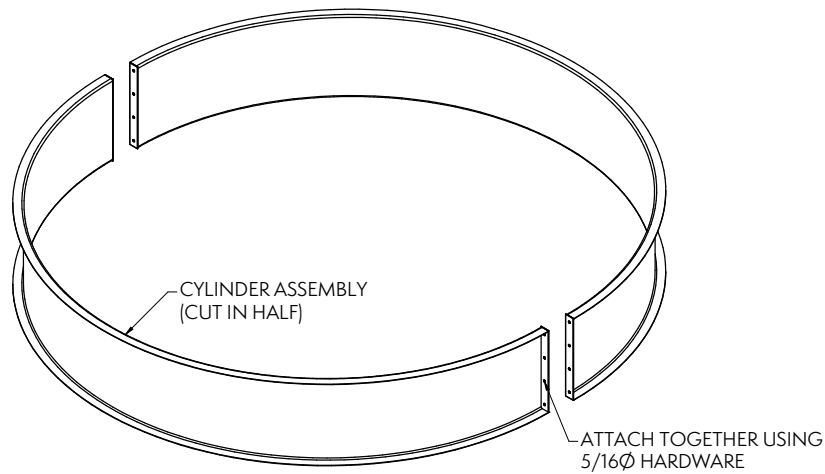

Figure 13 – Split Fan Cylinder for Standard Height Container Shipment

Figure 14 shows a 7' x 12' unit with super low sound fan shipping in a 40' standard height shipping container. Any containerized unit selected with Super Low Sound Fans will ship in 3 pieces as shown below.

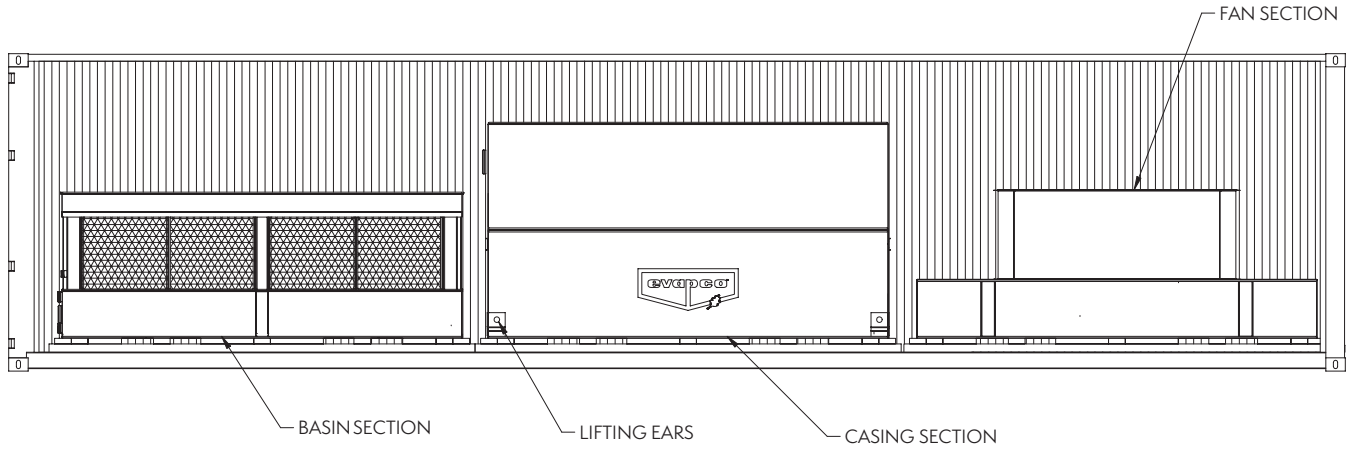
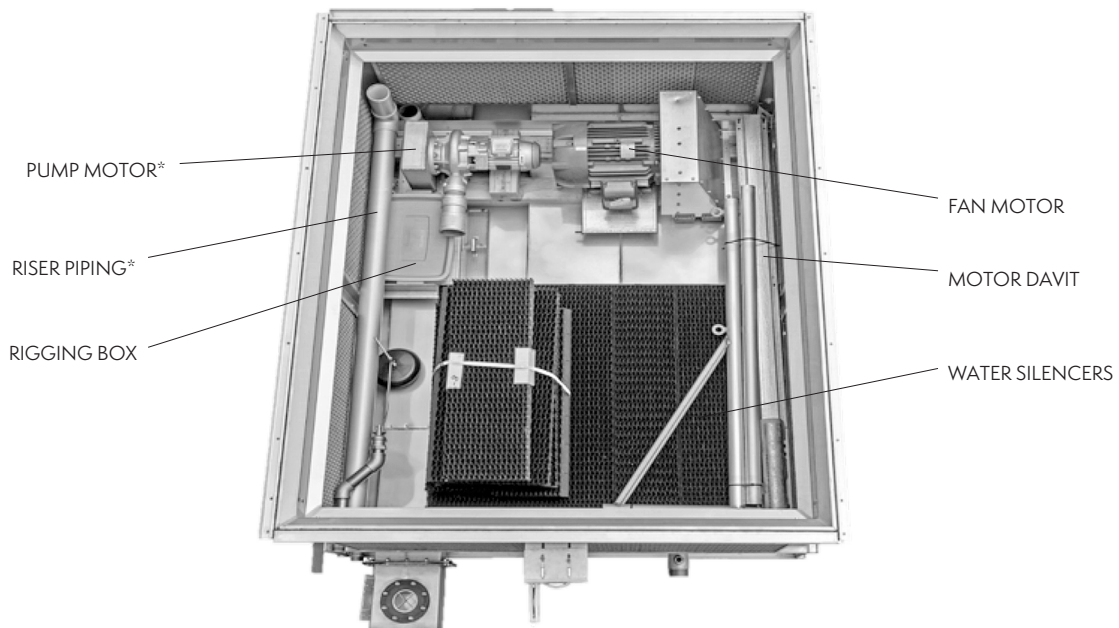

Figure 14 – 40' Standard Height Container, Unit with Super Low Sound Fan

Once the sections have been unloaded from the shipping container, follow the below steps to complete assembly. Please check table of contents for associated page numbers to get to the instructions referenced below.

1. Unbolt fan section from basin section.
2. Lift fan section and rig to casing section using instructions from **“3-Section Shipments.”**
3. Rig basin section using instructions from **“Rigging Bottom Sections.”**
4. Lift upper section (fan + casing) and rig to basin using instructions from **“Rigging Upper Sections,”** and **“Assembly of Upper Sections to Bottom Sections.”**

While the image below is not representative of all possible accessory options, but it provides an example of how containerized unit basins are set up for shipment. Platforms and ladders are strapped to the top of the casing.



* On Coolers & Condensers only. Not applicable to towers.

Installing Watertight Partitions & FM Partition Panels

In some cases, a multi-cell unit is ordered with watertight partitions to allow for independent cell operation. To correctly assemble the upper sections to the bottom sections, access to the rigging seams in between cells is necessary. To facilitate with this access, the upper watertight partition is shipped loose for installation in the field. **Figure 15** below provides instruction to install these in the field.

NOTE: The below instruction and arrangement also applies for Factory Mutual (FM) Approved multi-cell units, in which case these partitions will be referred to as FM Partition Panels.

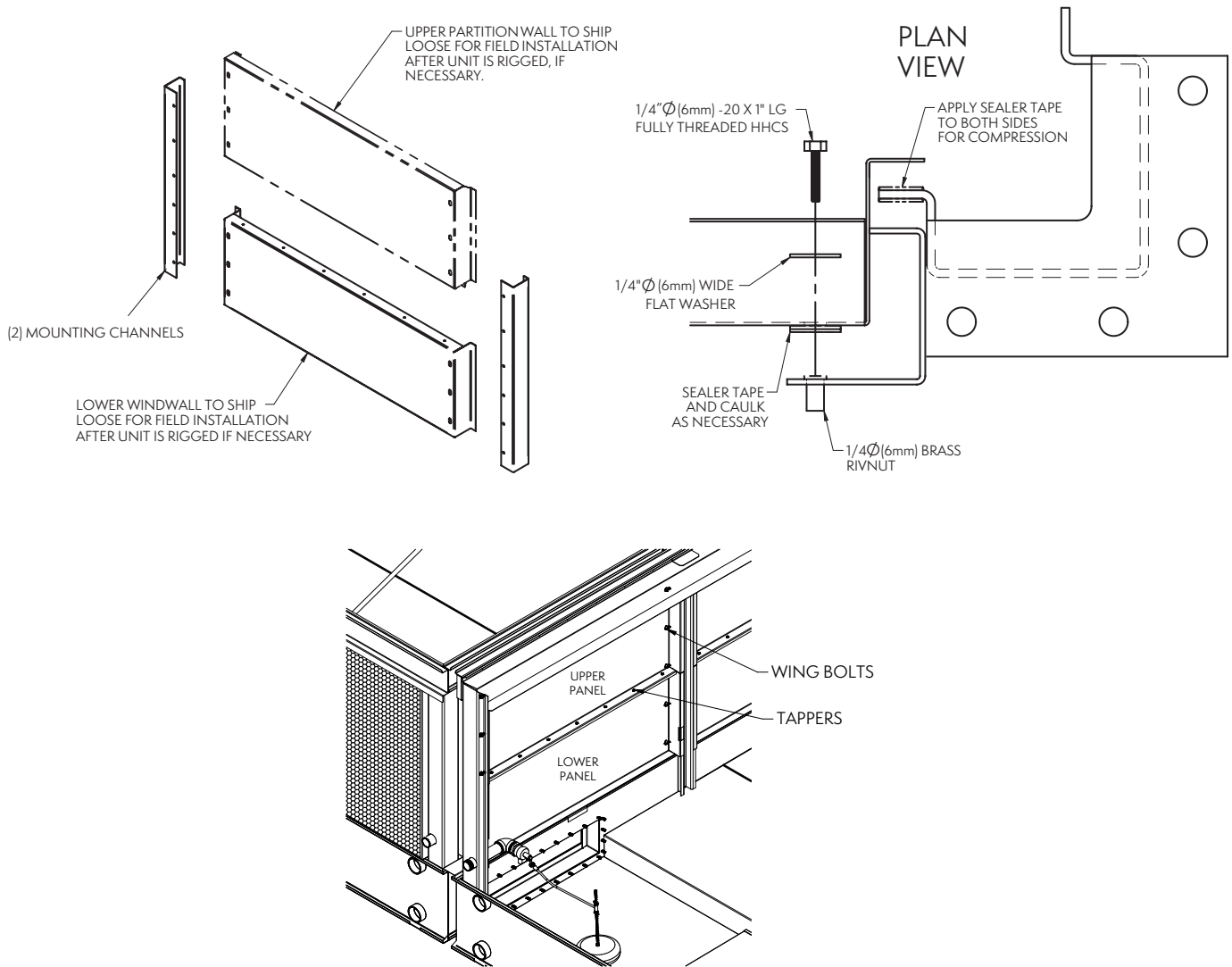

Figure 15 – Upper Partition/Firewall Installation in Field

Rigging Fully Assembled Units

Table 8 lists units which can be rigged with upper and lower section fully assembled and provides the recommended minimum “H” dimension. 10’ (3m), 12’ (3.6m), and 14’ (4.3m) wide single cell units cannot be rigged fully assembled without modification. Multi-cell units cannot be rigged fully assembled.

NOTES:

Any unit not listed in the table below cannot be rigged fully assembled.

On units with two fans per top section, models AT 14-2E9 through AT 14-3G12, spreader bars must always be used between the cables at the top of the unit to prevent damage to the fan cylinders.

Section Width		Section Length		Minimum “H” Dimension	
Feet	Meters	Feet	Meters	Feet	Meters
4	1.2	4	1.2	5	1.5
		6	1.8	6	1.8
		9	2.7	8	2.4
		12	3.6	11	3.4
6	1.8	8.5	2.6	7	2.7
7	2.24	9	2.7	9	2.7
		12	3.6	10	3
8/8.5	2.4/2.6	6	1.8	7	2.7
		7.5	2.4	8	2.4
		9	2.7	9	2.7
		10.5	3.2	10	3
		12	3.6	10	3
		14	4.3	12	3.6

Table 8– Minimum “H” Dimension for Lifting Fully Assembled Units

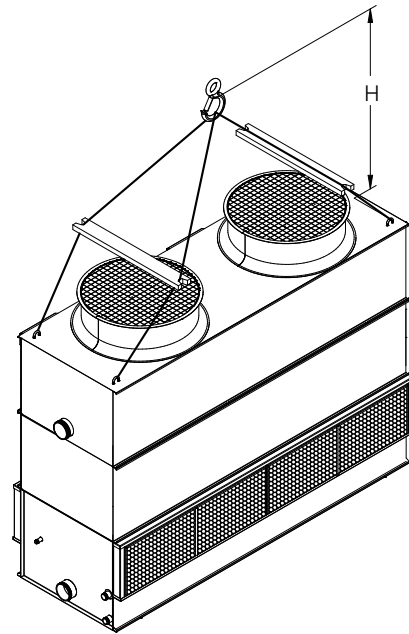

Figure 16a – 4’ (1.2m) Wide Two-Fan Fully Assembled Unit

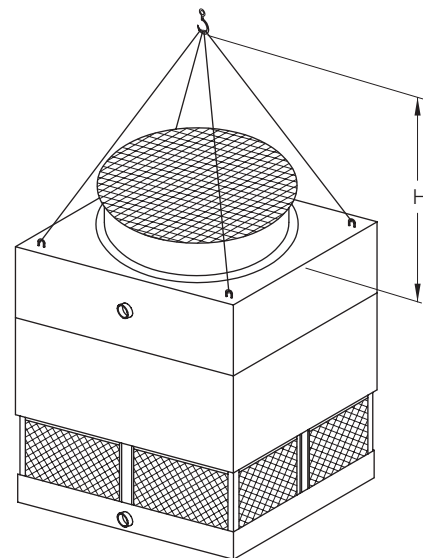

Figure 16b – 8.5’ (2.6m) Wide Fully Assembled Unit

External Motor Installation – Belt Drive

All units narrower than 10' (3m) wide have their motors installed outside the unit in a shaft up configuration as shown in **Figures 17a** and **17b** below. Due to shipping width restrictions, these motors cannot ship mounted on the units since they would extend past the width of the truck. For this reason, the motor(s), motor base(s), motor guard(s), J-bolts, pivot pins and belt(s) are shipped in the cold-water basin of the cooling tower. Please follow the step-by-step instructions below to properly install these components.

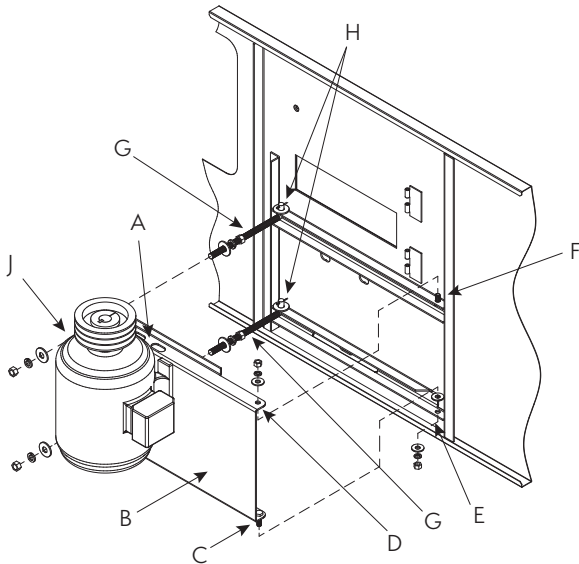

Figure 17a – External Motor Installation

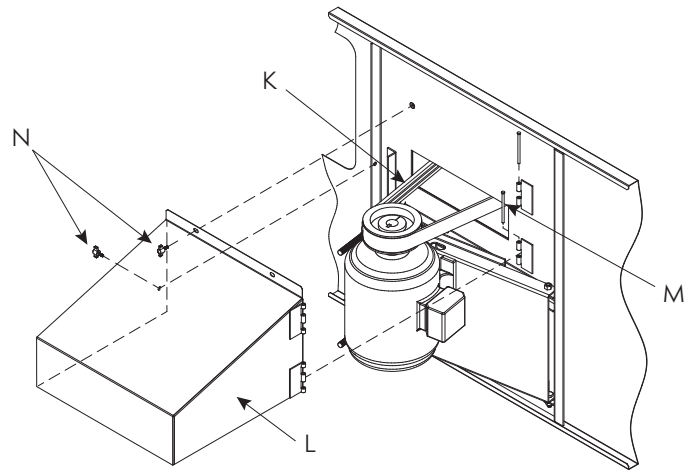

Figure 17b – Motor Guard and Power-Band Belt Installation

1. Study **Figure 17a** above before installing the motor base on the unit.
2. Insert the lifting device into the slots **A** located on the top of the motor base.
3. Lift the motor base **B** and insert the pivot pin **C** down into hole **E** and pivot pin **F** into hole **D**.
4. Install washer and nut (do not overtighten) on pivot pins. Install jam nut on pivot pin **C**.
5. Insert J-bolts **G** into holes **H**. Install flat washers and cotter pins. Place nuts and washers on threaded portion of J-bolts. These will be behind the motor base installed in the next step.
6. Install J-bolts **G** into holes **J** in the motor base. Install flat washers, lock washer and nuts. Remove lifting device from the motor base. Position motor base towards top section of unit for belt installation.
7. Install Power-Band belt **K** (**Figure 17b**) around fan sheave and motor sheave. Tighten belt by adjusting nuts on J-bolts. Do not overtighten the belts. The center of the belt should deflect approximately 1/2" (13 mm) in the horizontal plane with moderate hand pressure.
8. Measure to see that the top and bottom of the motor base are the same distance out from the casing of the unit. This will ensure that the sheaves are properly aligned since the driven sheave on the fan shaft comes preset from the factory.
9. As a final check, lay a straight edge from sheave to sheave as shown below in **Figure 18**. There should be four-point contact. Adjust the position of the motor sheave as necessary until four-point contact is achieved.
10. To install motor guard **L**, match up hinges and install hinge pins **M** as shown in **Figure 17b**.
11. Close motor guard **L** and install wing bolts **N**.

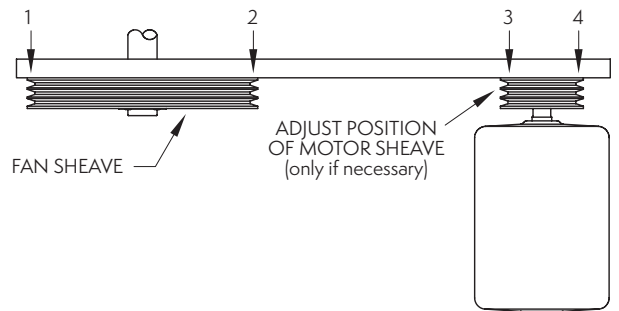

Figure 18 – Sheave Alignment Check

NOTE: For European markets, additional belt cover plate needs to be installed.

Optional Motor & Gear Box Davit Installation

Motor davits, also known as jib-booms, are offered by EVAPCO as an optional accessory to facilitate removal of the motor, fan assembly or gear box. The assembly consists of a davit and a mounting base that is to be attached to the side of the unit next to the access door, as shown below in **Figure 19**. Both these items will ship loose in the unit's basin. On multi-cell units, there will be provisions to install a mounting channel on each cell. Use the following procedure to install the mounting channel:

1. Align the mounting channel with 3/8" (10mm) bolts and flat washers to the factory installed mounting brackets.
2. Use 3/8" (10mm) flat washers, lock washers and nuts to secure the mounting channel to the bracket, as shown in **Figure 20**.

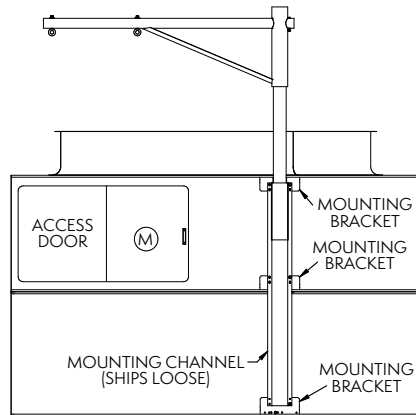

Figure 19 – Dual-Point Davit Arrangement

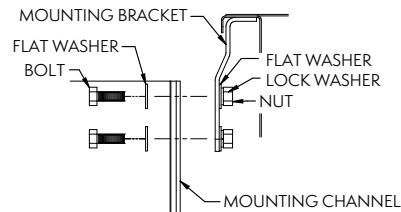

Figure 20 – Mounting Channel Installation

External Motor Installation – Gear Drive

1. Mount the motor base assembly to the motor base yoke using (4)* 3/8" (10mm) x 1-1/2" (38mm) grade 5 bolts on each side of the motor base assembly. Do not fasten any hardware until step 2 is complete.
2. In addition to the grade 5 bolts, install (2) 5/16" (8mm) spring pins on each side of the motor base assembly as shown in **Figure 21**.
3. Use flat washers, lock washers and nuts to secure the grade 5 bolts mentioned in step 1.

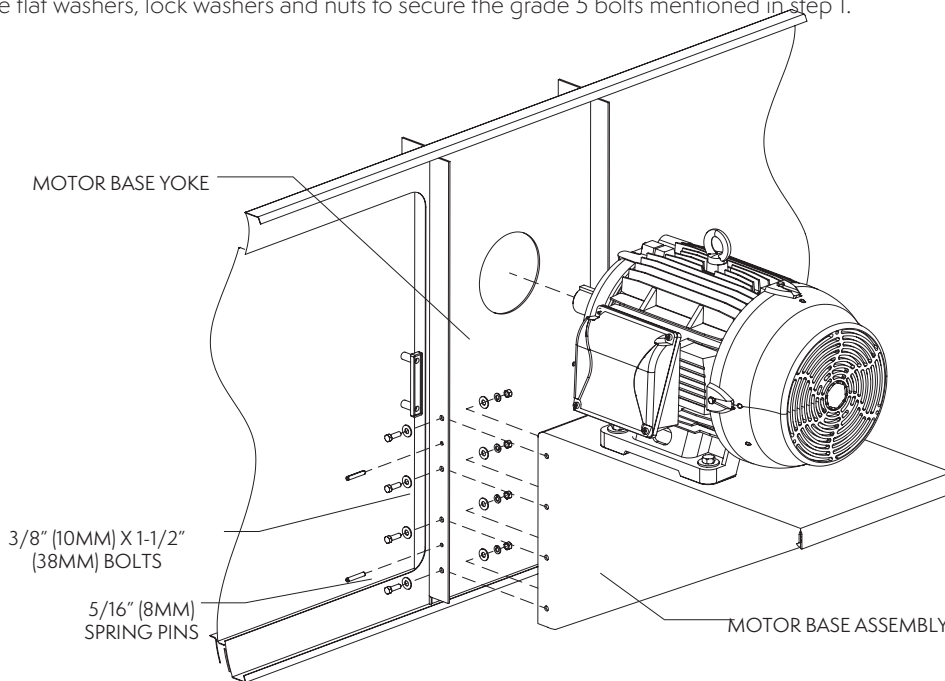

Figure 21 – External Motor Installation for Gear Drive Applications

**8.5' Wide Cooling Towers will require (5) 3/8" (10mm) x 1-1/2" (38mm) grade 5 bolts on each side of the motor base assembly.*

Floating Shaft Installation & Alignment

Before proceeding with the steps that follow, please ensure that the motor and the gearbox are level with respect to themselves.

1. Mount the drive shaft with the flexible element assembly on the gear drive input shaft using the supplied 3/8" (10mm) hardware. All bolts, lock washers and nuts are supplied with the drive shaft kit.
2. Insert steel bushings into the composite flexible elements on the motor and gear sides.
3. Mount the drive shaft with the flexible element assembly on the motor output shaft using the supplied 3/8" (10mm) hardware. All bolts, lock washers and nuts are supplied with the drive shaft kit.
4. Torque requirements for the bolts are listed in the table below; These values are dependent upon the shaft model.

Shaft Model	Torque Requirement
LR_350	400 in-lbs (33 ft-lbs 45 Nm)
LR_375	400 in-lbs (33 ft-lbs 45 Nm)
LR_450	145 in-lbs (12 ft-lbs 16 Nm)
LR_485	240 in-lbs (20 ft-lbs 27 Nm)
Amarillo Model 52	100 in-lbs (8.33 ft-lbs 11.30 Nm)
Amarillo Model 60	310 in-lbs (25.83 ft-lbs 35.03 Nm)

Table 9 – Torque Requirements for Floating Shaft Assemblies

5. Check angular and axial misalignment between the drive shaft and both the motor and gear couplings.

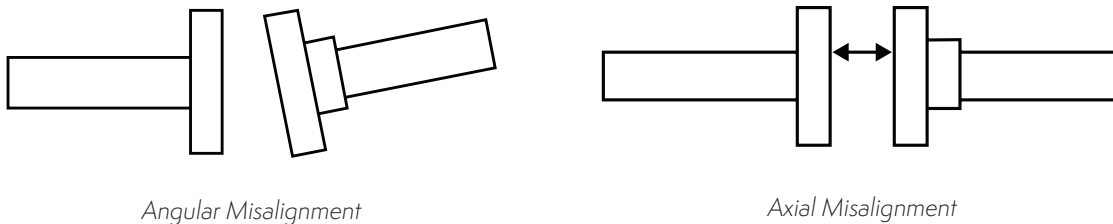

Figure 22 – Checking Angular and Axial Misalignment

6. Check angular misalignment with a dial indicator on *gear drive side*, as shown in **Figure 23**.
7. Attach the dial indicator support to the drive shaft and position the indicator tip to read off the opposite side flange.
8. With the dial indicator set to zero, rotate the shaft 360° and record the indicator readings at 90° increments.
9. Acceptable angular alignment shown in Table 10.

Shaft Model	Angular Alignment
LR_350	0.010 in (0.25 mm)
LR_375	0.010 in (0.25 mm)
LR_450	0.010 in (0.25 mm)
LR_485	0.010 in (0.25 mm)
Amarillo Model 52	0.030 in (0.76 mm)
Amarillo Model 60	0.035 in – 0.89 MM

Table 10 – Angular Alignment

10. When the angular alignment is within the acceptable ranges as mentioned in step 9, securely tighten all gear drive hardware.

11. Repeat steps 7, 8 and 9 to check angular misalignment with a dial indicator on *motor side*.
12. When the angular alignment is within the acceptable ranges as mentioned in step 9, securely tighten all motor hardware.
13. Re-check alignment with the dial indicator at both the gear drive and the motor ends to ensure that misalignment did not occur during final bolt tightening.

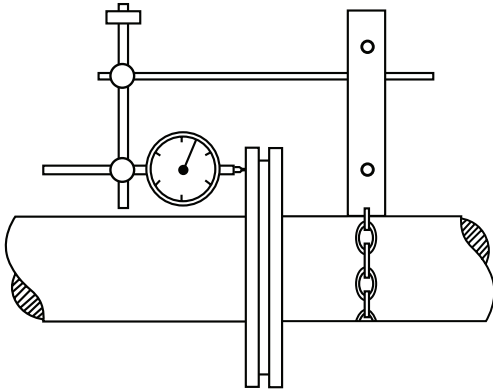

Angular Misalignment Check with Dial Indicator

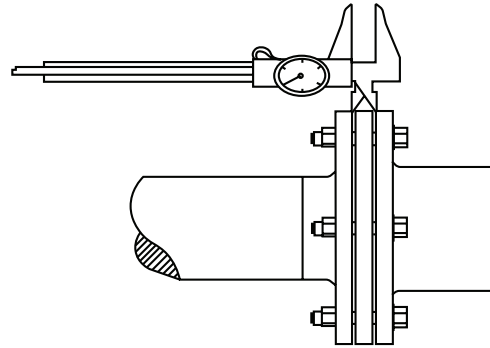

Axial Misalignment Check with Dial Caliper

Figure 23 – Checking Angular and Axial Misalignment

14. Check axial misalignment (hub separation) with the dial caliper on both the gear drive side and the motor side (See **Figure 23**).
15. Without rotating the shaft, measure the gap between the shaft flange and the hub flange on both ends. Take four (4) readings around the perimeter at 90° intervals.
16. Acceptable axial alignment shown in Table 11.

Shaft Model	Nominal Gap	Tolerance
LR_350	0.43 in (10.92 mm)	+/- 0.01 in (+/- 0.25 mm)
LR_375	0.54 in (13.72 mm)	+/- 0.01 in (+/- 0.25 mm)
LR_450	0.43 in (10.92 mm)	+/- 0.01 in (+/- 0.25 mm)
LR_485	0.60 in (15.24 mm)	+/- 0.02 in (+/- 0.51 mm)
Amarillo Model 52	0.785 in (19.94 mm)	+/- 0.03 in (+/- 0.76 mm)
Amarillo Model 60	0.785 in (19.94 MM)	+/- 0.03 in (+/- 0.76 MM)

Table 11 – Axial Alignment

17. Your floating shaft assembly installation is now complete.

NOTE: All floating shafts ship loose for field installation and alignment by others.

Mounting Fan Screens

On 10' (3m) wide units and larger, a conical fan screen support is used in order to prevent the fan screen from sinking down into the fan cylinder. In some cases, shipping height restrictions may require the fan screen support(s) and fan screen(s) to ship loose for installation in the field. Please follow the below instructions to install these components on the fan cylinder(s).

1. Set the fan screen support across the top of the fan cylinder as shown in **Figure 24**.
2. Place both halves of the fan screen on top of the fan screen support. Each half will be tagged to match markings on the cylinder. Align the eyelets of the fan screen with the holes on the cylinder perimeter.
3. Join the two screen halves with U-bolts, as shown in **Figure 25**.
4. At each hole, attach the fan screen to the fan cylinder as shown in **Figure 24**. At the four* points where the fan screen support meets the cylinder, bolt the support to the cylinder together with the fan screen.

*Fan Screens on units with Super Low Sound Fans have eight points.

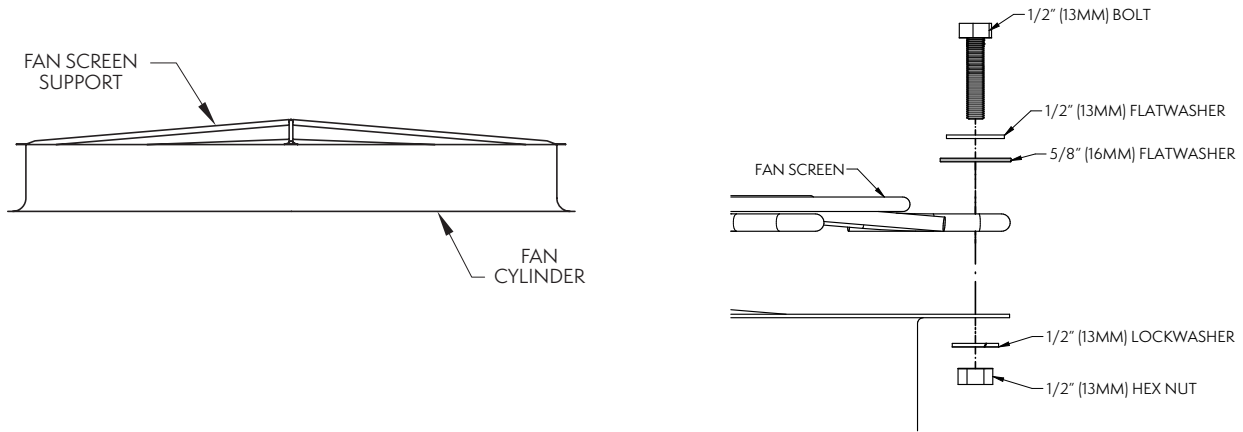

Figure 24 – Fan Screen Support & Fan Screen installation

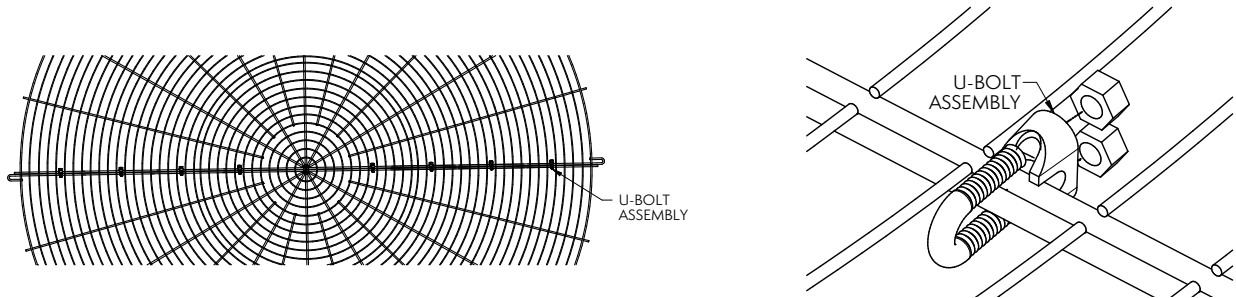

Figure 25 – U-Bolt Assembly Spacing & Arrangement

NOTE: European market sometimes utilizes alternative CE compliant fan screen with 30mm x 30mm mesh. Screen has 120mm clearance from trailing edge of fan blades.

Sloped Ladder Installation

When sloped ladders are supplied with a unit, they are shipped in the unit's basin. One sloped ladder will be provided for each cell. Assembly is identical for each cell, unless otherwise noted in the submittal.

Sloped ladders are attached at a minimum of three points. At each point of attachment, the ladder will be fitted with a ladder bracket assembly. The ladder bracket assembly looks like a metal box and is shown as component (d) in **Figure 26** below. The upper two assembly brackets will be rigidly mounted to the ladder and are not adjustable. These two brackets define the slope of the ladder. The lower bracket(s) are adjustable.

To install the ladder assembly, complete the steps that follow. Refer to **Figure 26**:

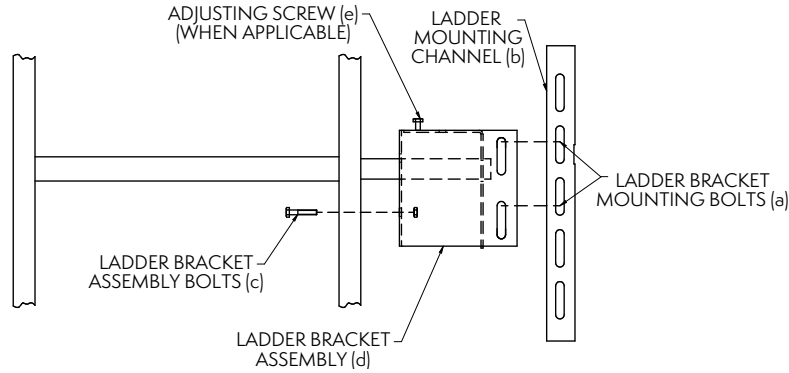

Figure 26 – Detail of Ladder, Ladder Bracket Assembly & Mounting Channel

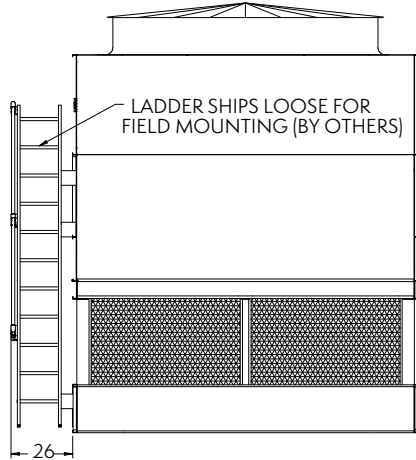

Figure 27a – End View of Ladder Assembly

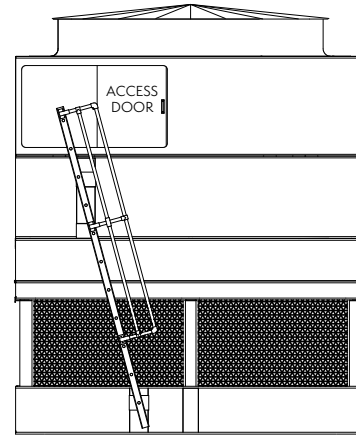

Figure 27b – Side View of Ladder Assembly

1. Remove the ladder bracket mounting bolts (a) from the ladder mounting channels (b) on basin and casing sections.
2. Loosen, but do not remove, the ladder bracket and assembly bolts (c).
3. Slide the bracket assembly (d) over the ladder mounting channels (b) located on the pan and casing sections. Do not remove the ladder bracket assembly (d) from the ladder.
4. Align the bolts and reinstall the ladder bracket assembly mounting bolts (a) through the ladder bracket assembly and the ladder mounting channels (b).
5. Tighten all bolts.
6. Tighten the adjusting screw (e) in the adjustable mounting bracket where applicable.

NOTES:

Upper section of unit must be properly oriented with respect to the lower section.

All mounting brackets must be on the same side of the unit. Refer to submittal for proper orientation.

Sloped ladders are not CE compliant & are not available for European market.

External Platform and Vertical Ladder Installation

If your unit is accessorized with an external service platform assembly with a vertical ladder, this equipment is shipped in the basin of your unit. In some cases, they are shipped separately due to other basin accessories that may interfere with storage. The platform is partially assembled prior to shipment to minimize field assembly.

Typically, there is one working platform and ladder assembly per fan section. Refer to your factory submittal for details.

The platform and ladder assembly should be attached after the unit is fully rigged, by following the instructions in the drawing below.

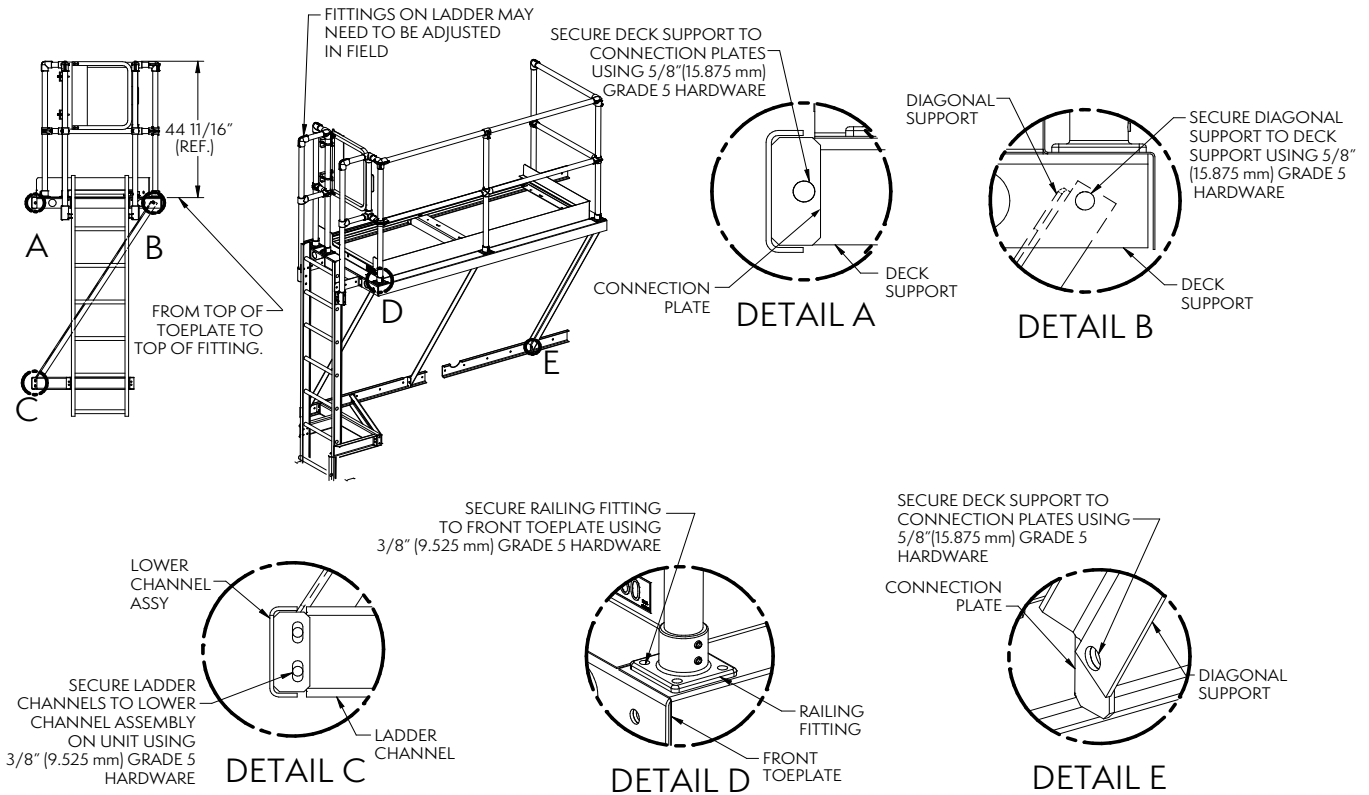

NOTE:
PLATFORM GRATING NOT SHOWN FOR CLARITY

Figure 28a – Platform Mounting General Arrangement - Configuration A



External Platform and Vertical Ladder Installation

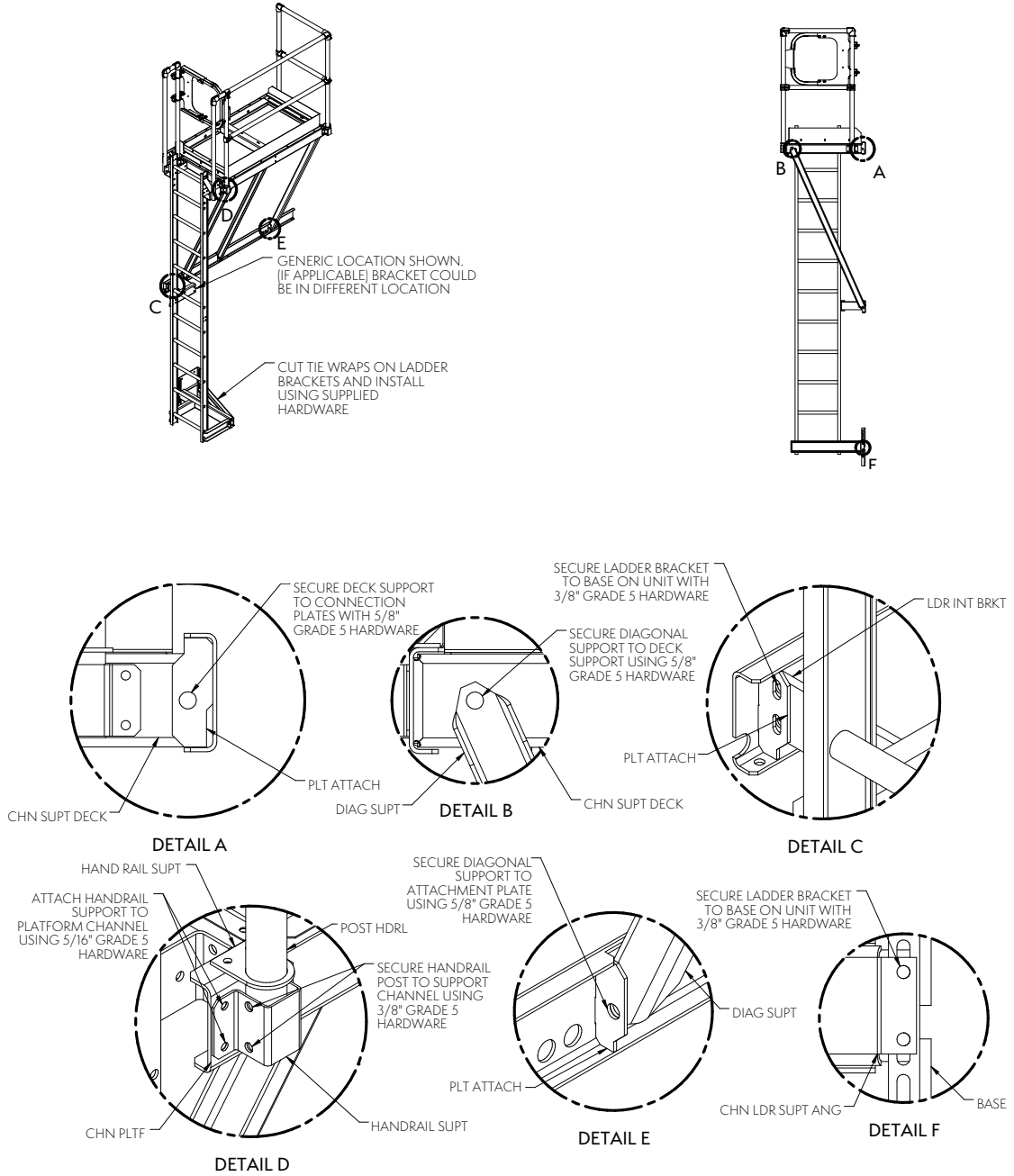

NOTE:
PLATFORM GRATING NOT SHOWN FOR CLARITY

Figure 28b – Platform Mounting General Arrangement - Configuration B

ASME Flange Pattern Sealing Instructions

If unit is provided with optional Bolt Pattern, follow the instructions below for proper connection of flange. EVAPCO will provide the sealer tape and backer plate. **Flange, gasket, and hardware are provided by others.**

NOTES:

Flange connection conforms to ASME B16.5 class 150 specification. Flat face flange, full face gasket, and fasteners supplied by others. All piping shall be externally supported by others. Piping must not be supported by the tower. Caulk all bolt heads and flat washers after all bolts are tightened. Caulk perimeter backer plate.

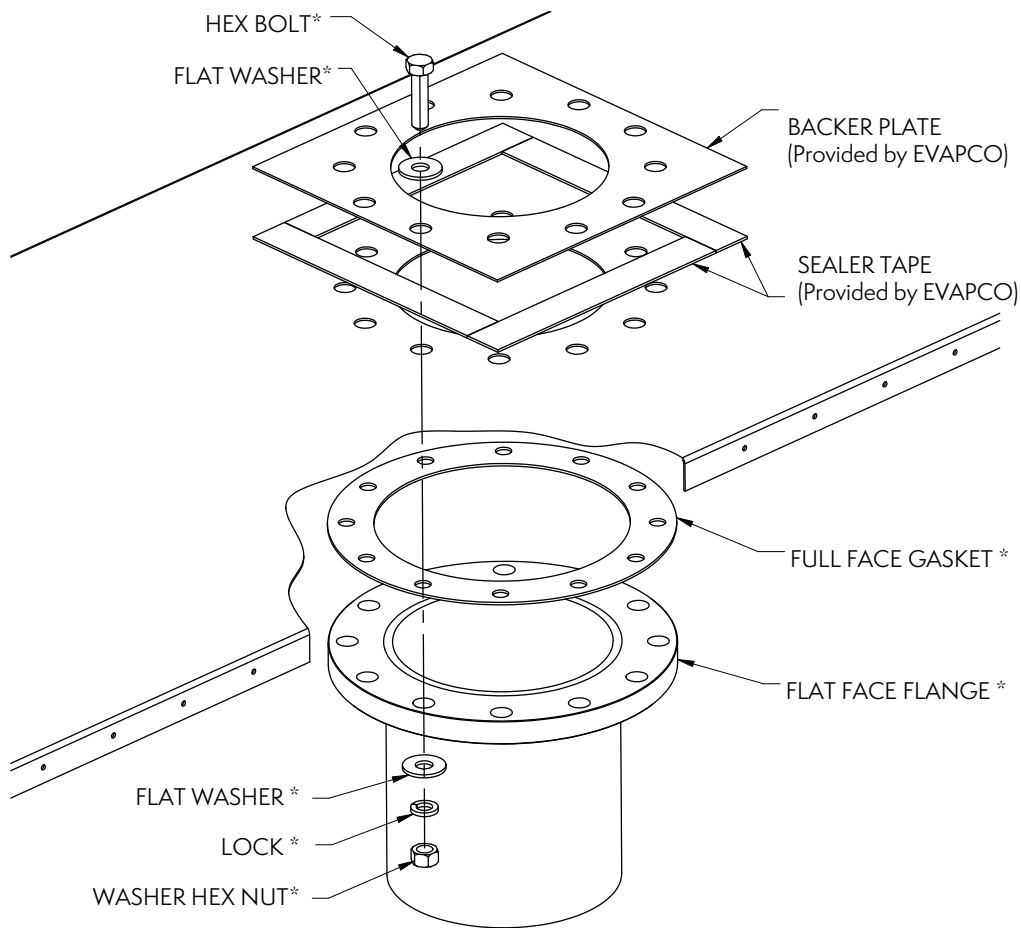

* Supplied by others

Figure 29 – ASME Flange Pattern Sealing

Field Assembly of Bottom Inlet

On 10' (3m) wide units and larger, the option is available to locate the inlet connection on the bottom of the unit. In such cases, internal piping is provided which allows the process water to make its way to the hot water distribution system. Please follow the below steps to complete field installation of the bottom inlet option after the unit is rigged.

1. Assemble the cooling tower in accordance with the rigging and assembly instructions provided.
2. Locate the bottom inlet assembly components, namely the riser pipe, two flexible reinforced pipe connectors and four pipe clamps per cell. 14' (4.3m) wide AT towers have eight pipe clamps per cell. These components are fastened securely in the unit's basin prior to shipment.
3. Remove the shipping strap supporting the upper pipe in the casing. This must be removed prior to installing the riser pipe.
4. Position the riser pipe assembly above the lower pipe nipple in the basin section.
5. Loosen the pipe clamps and slip the pipe connector down over the lower pipe nipple.
6. Align the bottom inlet connection assembly with the upper pipe nipple in the bottom of the fill/casing section, loosen the pipe clamps and slip the pipe connector up over the upper pipe nipple.
7. Tighten all pipe clamps. A ratchet wrench is recommended.
8. Repeat this process for each cell in a multi-cell arrangement.

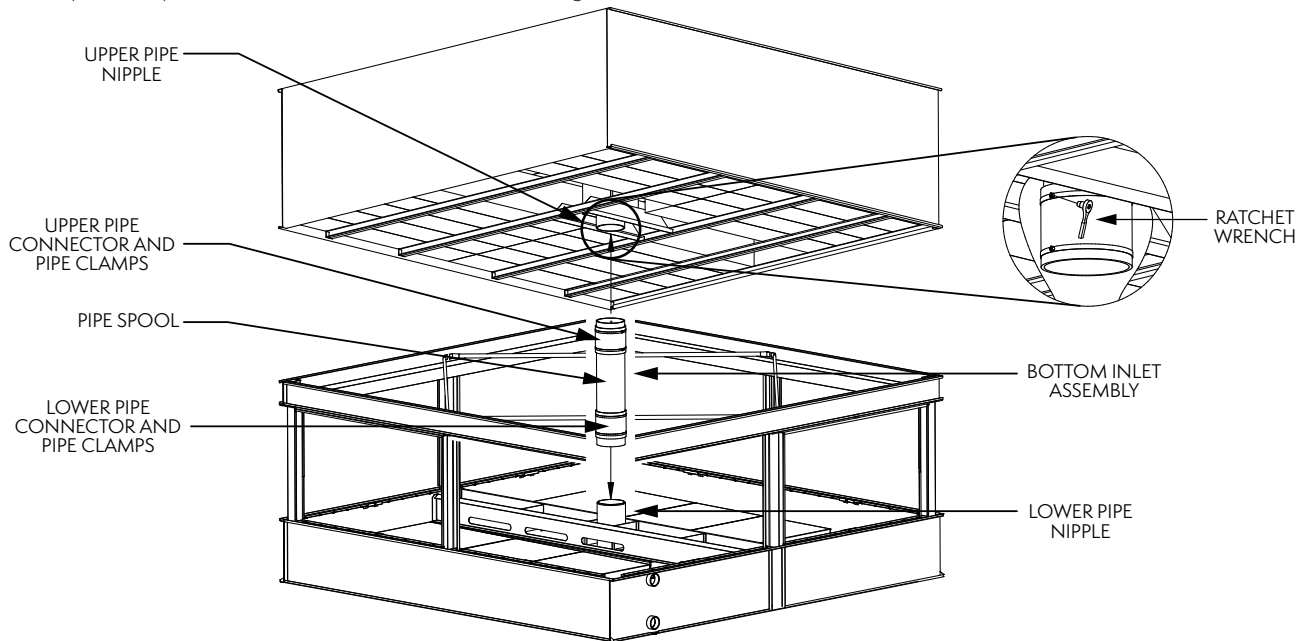
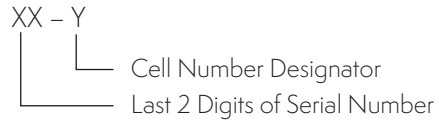

Figure 30 – Bottom Inlet Riser Pipe Installation

Appendix A

Units are provided with match markings on each section. Standard match marking location is at the rigging seam on the connection face. Standard match marking designation is shown below:



Example:

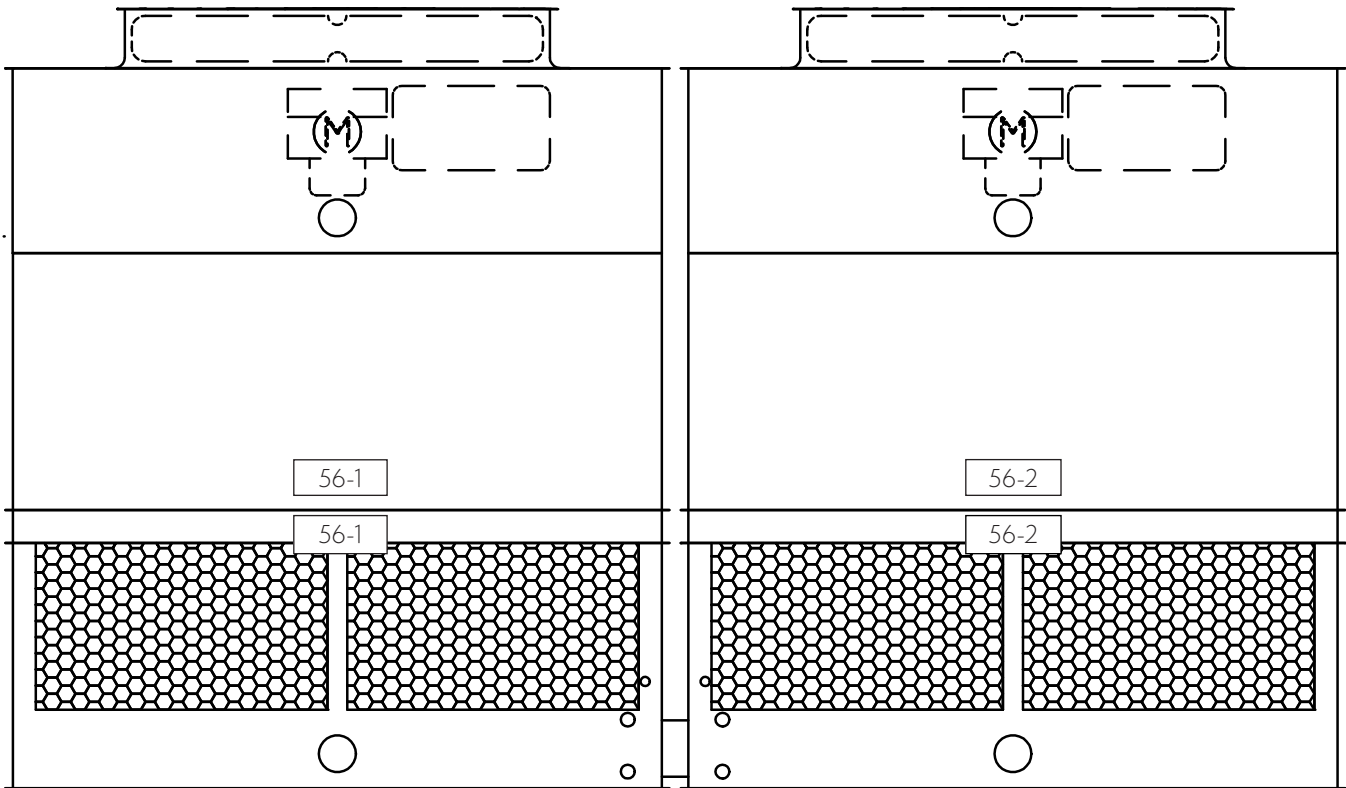
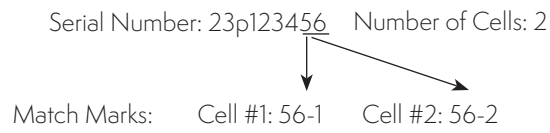



EVAPCO, Inc. • P.O. Box 1300 • Westminster, MD 21158 USA
Phone: 410.756.2600 • Fax: 410.756.6450 • E-mail: marketing@evapco.com

©2024 EVAPCO, Inc.



Printed on recycled paper
using soy-based ink