

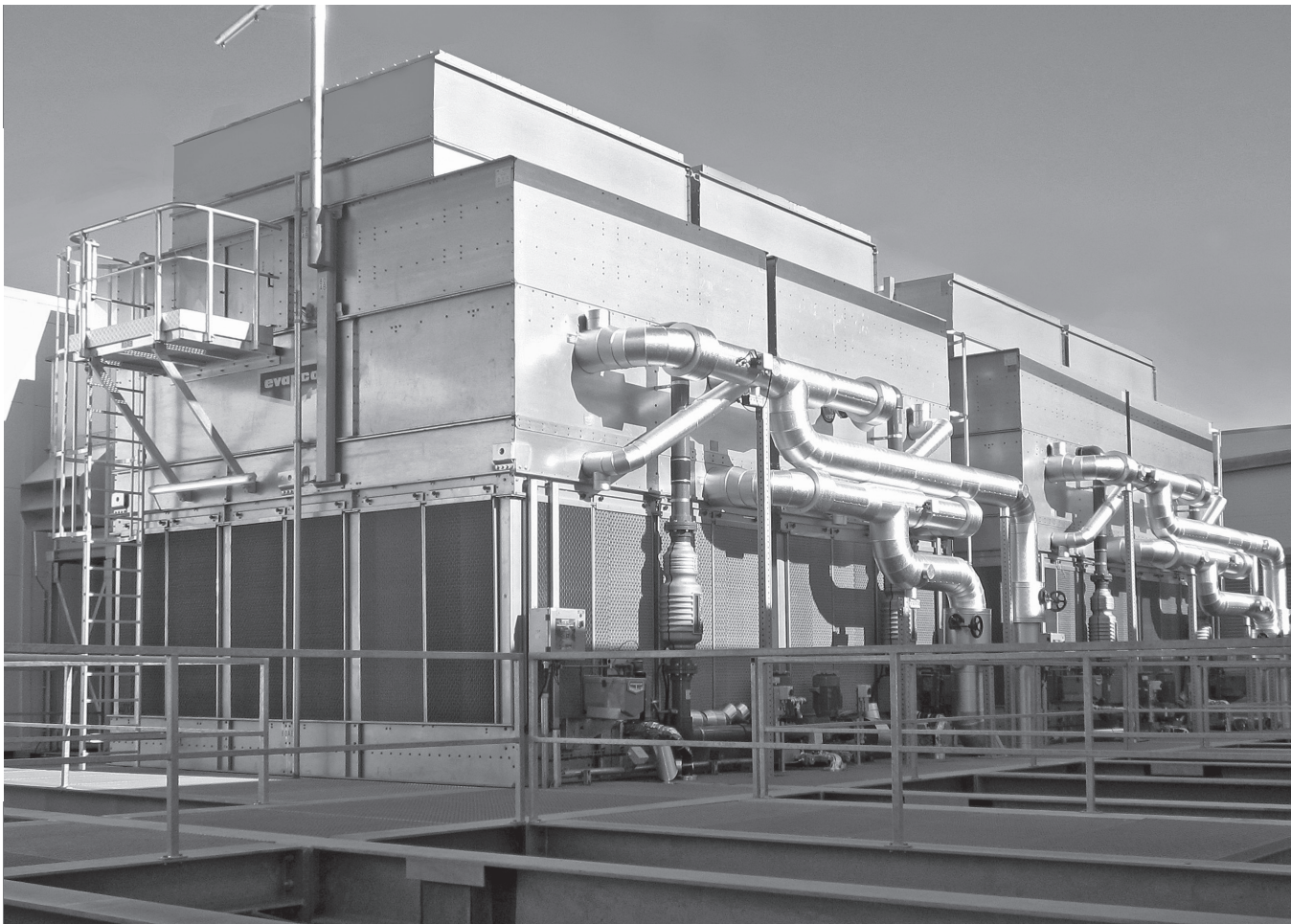

Operation and Maintenance Instructions

For EVAPCO Closed Circuit Coolers and Evaporative Condensers



[†] Mark owned by the Cooling Technology Institute

Table of Contents

3	Introduction	
3	Safety Precautions	
3	Terminology	
4	Initial Storage and/or Idle Period Recommendations	
5	International Building Code Provision	
5	Initial and Seasonal Startup Checklist	
6	General	
6	Initial and Seasonal Startup	
7	Recommended Maintenance Schedule	
9	Seasonal Shutdown Checklist	
10	Basic Closed Circuit Cooler/Condenser Sequence of Operation	
11	Fan System	
11	Fan Motor Bearings	
11	Fan Shaft Ball Bearings	
12	Fan Belt Adjustment	
13	Fan Belt Adjustment – Induced Draft	
14	Fan Belt Adjustment – Forced Draft	
14	Gear Drives	
14	Air Inlet	
14	Coil Inlet	
15	Fan System – Capacity Control	
15	Fan Motor Cycling	
15	Sequence of Operation for Fan Motor Cycling	
15	Variable Frequency Drives	
15	Sequence of Operations / Guidelines for Multi-fan Units with a VFD during Peak Load	
16	Two-Speed Motors	
16	Sequence of Operation for Two Fan Units with Two-Speed Motors during Peak Load	
17	Recirculated Water System - Routine Maintenance	
17	Suction Strainer in Cold Water Basin	
18	Cold Water Basin	
18	Operating Level of Water in Cold Water Basin	
19	Water Makeup Valve	
19	Pressurized Water Distribution Systems	
20	Bleed-Off Valve	
20	Pump (When Supplied)	
21	Water Treatment and Water Chemistry	
21	Water Chemistry Parameters	
21	Acid	
21	Air Contamination	
22	Bleed or Blowdown	
22	Galvanized Steel - Passivation	
22	Control of Biological Contamination	
23	Gray Water and Reclaimed Water	
23	Soft Water	
24	Cold Weather Operation	
24	Unit Layout	
24	Freeze Protection of Recirculating Water	
26	Freeze Protection of Closed Circuit Cooler Coils	
27	Unit Accessories	
27	Cold Water Basin Heaters	
27	Remote Sumps	
27	Electric Water Level Control (EWLC)	
27	Vibration Cutout Switches	
27	Capacity Control Methods for Cold Weather Operation	
27	Induced Draft Unit Capacity Control	
28	Forced Draft Unit Capacity Control	
28	Ice Management	
28	Induced Draft Units	
29	Forced Draft Units	
30	Troubleshooting	
33	Replacement Parts	
33	Part Identification Drawings	
34	ATC-E/ATWB/eco-ATWB 4'x6' Wide Units	
35	ATC-E/ATWB/eco-ATWB 4'x9' & 4'x12' Wide Units	
36	ATC-E/ATWB/eco-ATC-A/eco-ATWB 7' Wide Units	
37	ATC-E/ATWB/eco-ATC-A/eco-ATWB 8' & 8.5' Wide Units	
38	eco-ATC-H/eco-ATWB-H 8.5' Wide Units	
39	ATC-E/ATWB/eco-ATC-A/eco-ATWB 10' & 12' Wide Units	
40	eco-ATC-H/eco-ATWB-H 10' & 12' Wide Units	
41	ESW4 8.5' Wide Units	
42	ESW4 12' Wide Units	
43	ESW4 14' Wide Units	
44	LSC-E/LSWE/eco-LSWE 4' Wide Units	
45	LSC-E/LSWE/eco-LSWE 5' Wide Units	
46	LSC-E/LSWE/eco-LSWE 8' Wide Units (Single Side Fans)	
47	LSC-E/LSWE/eco-LSWE 10' Wide Units	
48	LRC/LRWB/eco-LRWB 3' Wide Units	
49	LRC/LRWB/eco-LRWB 5' Wide Units	
50	LRC/LRWB/eco-LRWB 8' Wide Units	
51	PMC-E/eco-PMC 5' Wide Units	
52	PMRC and eco-PMRC 10' and 12' Units	
53	PHC-S 2.24m Wide-Single Side Air Inlet Units	
54	PHC-S 8.5' Wide-Single Side Air Inlet Units	
55	PHC-S 10' and 12' Wide-Single Side Air Inlet Units	
56	PHC-D 12' and 14' Wide-Two Sided Air Inlet Units	
57	PHW 12' and 14' Wide-Two Sided Air Inlet Units	
58 - 59	Notes	

Introduction

Congratulations on the purchase of your EVAPCO evaporative cooling unit! EVAPCO equipment is constructed of the highest quality materials and designed to provide years of reliable service when properly maintained.

Thoroughly clean road salt, dirt and debris from unit immediately after delivery. Residue left on product surfaces can cause damage that is not covered by any warranty.

Evaporative cooling equipment is often remotely located and periodic maintenance checks are often overlooked. It is important to establish a regular maintenance program and be sure that the program is followed. This bulletin should be used as a guide to establish a program. A clean and properly serviced unit will provide a long service life and operate at peak efficiency.

This bulletin includes recommended maintenance services for unit start up, unit operation and unit shutdown and the frequency of each. Please note: the recommendations of frequency of service are minimums. Services should be performed more often when operating conditions necessitate.

Become familiar with your evaporative cooling equipment. Refer to the isometric drawings located on pages 34-57 for information on the arrangement of components in your equipment.

If you should require any additional information about the operation or maintenance of this equipment, contact your local EVAPCO representative. You may also visit www.evapco.com for more information.

Safety Precautions

Qualified personnel should use proper care, procedures and tools when operating, maintaining or repairing this equipment in order to prevent personal injury and/or property damage. The warnings listed below are to be used as guidelines only.



This equipment should never be operated without fan screens and access doors properly secured and in place.



A lockable disconnect switch should be located within sight of the unit for each fan motor associated with this equipment. Before performing any type of service or inspection of the unit make certain that all power has been disconnected and locked in the "OFF" position.



The top horizontal surface of any unit is not intended to be used as a working platform. No routine service work is required from this area.



Building water systems receive potable and non-potable water from either a public or private entity for their water supply. This water supply for the building water system can contain various waterborne pathogens, including *Legionella* bacteria, which can cause or contribute to various illnesses if aspirated, ingested or inhaled. Since evaporative cooling equipment uses the same building water, there is some potential that these pathogens might propagate in the equipment. Therefore, careful consideration should be undertaken with respect to equipment location and the implementation of effective water management, inspection and cleaning protocols. (See Control of Biological Contaminants in these Operation and Maintenance Instructions.)

Terminology

Throughout this manual, the terms "Induced Draft" and "Forced Draft" are used. Below is a list of EVAPCO closed circuit cooler and condenser products offerings and associated terminology.

Induced Draft equipment includes the following EVAPCO product models:

- **ESW4 - Closed Circuit Cooler**

■ AT Product Lines

- ATWB - Closed Circuit Cooler
- ATC-E - Evaporative Condenser
- eco-ATWB - Wet/Dry Closed Circuit Cooler
- eco-ATWB-H - Wet/Dry Closed Circuit Cooler
- eco-ATC-A - Wet/Dry Evaporative Condenser
- eco-ATC-H Wet/Dry Evaporative Condenser

■ PHC-E - Parallel Hybrid Evaporative Condenser

■ PHW Parallel Hybrid Closed Circuit Cooler

Forced Draft equipment includes the following EVAPCO product models:

■ LR Product Lines

- LRWB - Closed Circuit Cooler
- LRC - Evaporative Condenser
- eco-LRWB - Wet/Dry Closed Circuit Cooler

■ LS Product Lines

- LSWE - Closed Circuit Cooler
- LSC-E - Evaporative Condenser
- eco-LSWE - Wet/Dry Closed Circuit Cooler

■ PM Product lines

- PMC-E - Evaporative Condenser
- eco-PMC - Wet/Dry Evaporative Condenser
- PMRC
- eco-PMRC - Wet/Dry Evaporative Condenser

Initial Storage and/or Idle Period Recommendations

If the unit will sit in storage or idle for long periods of time it is recommended that the following be performed in addition to all component manufacturers recommended maintenance instructions.

- If the unit(s) are going to be stored for longer than 3 weeks before being installed, all non-wired electrical components must be brought to a covered area. These items include, but not limited to, basin heater(s), heater controls, electronic water level controller(s), and vibration switch(es). Once in a covered area, follow component manufacturers recommended storage and maintenance instructions.
- The fan/motor/pump bearings need to be turned by hand at least once a month. This can be accomplished by tagging and locking out the unit's disconnect, grasping the fan assembly (or removing the pump motor fan guard), and rotating it several turns. If motor(s) are to sit longer than 3 months not wired, it must be brought to a covered area and continue to follow motor manufacturers recommended storage and maintenance instructions.
- If unit sits longer than a few weeks, run gear reducer (if equipped) for 5 minutes weekly, or check sheaves and bushings for corrosion. Scrape and coat with a $\geq 95\%$ zinc-rich compound (ZRC).
- If unit sits longer than 3 weeks, completely fill gear reducer with oil. Drain to normal level prior to running.
- If the unit sits longer than 3 weeks, lubricate the fan shaft bearings and motor adjustment all-thread bolt.
- If unit sits longer than one month, insulation test motor windings semi-annually.
- If fan motor sits idle for at least 24 hours while the spray pumps are energized distributing water over the coil, motor space heaters (if equipped) should be energized. Alternatively, fan motors may be energized for 10 minutes, twice daily, to drive any moisture out of the motor windings.
- If coil sits longer than one month, nitrogen charge the coil.
- Energize fan motors space heaters.

International Building Code Provisions

The International Building Code (IBC) is a comprehensive set of regulations addressing the structural design and installation requirements for building systems – including HVAC and industrial refrigeration equipment. The code provisions require that evaporative cooling equipment and all other components permanently installed on a structure must meet the same seismic design criteria as the building.

All items attached to EVAPCO closed circuit coolers or evaporative condensers must be independently reviewed and isolated to meet applicable wind and seismic loads. This includes piping, ductwork, conduit, and electrical connections. These items must be flexibly attached to the EVAPCO unit so as not to transmit additional loads to the equipment as a result of seismic or wind forces.

Initial and Seasonal Startup Checklist

General

- 1. Verify that the overall installation reflects the requirements of the installation guidelines found in EVAPCO Bulletin 311 – Equipment Layout Manual available at www.evapco.com.
- 2. Fan motor space heaters: To prevent any moisture buildup in the windings and bearings, space heaters are provided as standard on every fan motor. These should be wired prior to operation.
- 3. For multi-speed fan motors, verify that 30 second or greater time delays are provided for speed changes when switching from high to low speed. Also check to see if interlocks are provided to prevent simultaneously energizing high and low speed, and confirm both speeds operate in the same direction.
- 4. Verify all safety interlocks work properly.
- 5. For units operating with a variable frequency drive, make certain that minimum speed requirements have been set. Check with VFD manufacturer for recommended minimum speeds. See “Fan System - Capacity Control” section for more information, and recommendations on locking out resonance frequencies.
- 6. Verify that a water treatment plan has been implemented including passivation of galvanized steel units. See “Water Treatment and Water Chemistry” section for more details.
- 7. If the unit is going to sit idle for an extended period of time, follow all manufacturers’ fan motor and pump instructions for long-term storage. Plastic sheets or tarps should never be used to protect a unit during storage. This practice can trap heat inside the unit, and could potentially cause damage to plastic components. See your local EVAPCO representative for additional information on unit storage.

BEFORE BEGINNING ANY MAINTENANCE, BE CERTAIN THAT THE POWER IS TURNED OFF AND THE UNIT IS PROPERLY LOCKED AND TAGGED OUT!

Initial and Seasonal Startup

- 1. Clean and remove any debris, such as leaves and dirt from the air inlets.
- 2. Flush the cold water basin (with the strainer screens in place) to remove any sediment or dirt.
- 3. Remove the strainer screen, clean **and reinstall**.
- 4. Check mechanical float valve to see if it operates freely.
- 5. Inspect water distribution system nozzles and clean as required. Check for proper orientation.
(This is not required at initial startup. The nozzles are clean and set at the factory).
- 6. Check to ensure drift eliminators are securely in place and in the proper orientation.

Initial and Seasonal Startup Checklist (Continued)

- 7. Adjust fan belt tension as required. See "Fan Belt Adjustment" section.
- 8. Lubricate fan shaft bearings prior to seasonal startup.
- 9. Turn the fan(s) and pumps by hand to insure it turns freely without obstructions.
- 10. Visually inspect the fan blades. Blade clearance should be approximately 3/8" (1/4" minimum) from tip of blade to the fan cowl. The fan blades should be securely tightened to the fan hub.
- 11. If any stagnant water remains in the system including "dead legs" in the piping, the unit must be disinfected prior to the fans being energized. Please refer to ASHRAE Guideline 12 and CTI Guideline WTP-148 for more information.
- 12. Manually fill the cold water basin up to the overflow connection.
- 13. For closed circuit coolers, fill the heat exchanger coil with the specified fluid and "burp" air from the system before pressurizing, using vents on coil inlets. Do not do this for evaporative condensers.

NOTE: Closed circuit coolers should only be used on sealed, pressurized systems. Continual aeration of the water in an open system can cause corrosion inside the tubes of the cooler leading to premature failure.

For closed circuit coolers with optional controls, see controls O&M for proper startup procedure.

After the unit has been energized, check the following:

- 1. Adjust mechanical float valve as required to the proper water level.
- 2. Unit basin should be filled to the proper operating level. See "Recirculating Water System Operating Levels" section for more details.
- 3. Verify fan(s) is rotating in proper direction.
- 4. Start the spray water pump(s) and check for proper rotation as indicated by the arrow on the front cover.
- 5. Measure voltage and current on all three power leads of pump and fan motor. The current should not exceed the motor nameplate full load amp rating taking the service factor into account.
- 6. Consult your qualified water treatment company to fine tune the minimum bleed necessary, see "Water Treatment and Water Chemistry" section.
- 7. See fan and pump motor manufacturer maintenance and long-term storage instructions for more detailed information. The motors should be lubricated and serviced in accordance with manufacturer's instructions.
- 8. All new evaporative cooling equipment and associated piping should be precleaned and flushed to remove grease, oil, dirt, debris, and other suspended solids prior to operation. Any precleaning chemistry should be compatible with the cooling equipment's materials of construction. Alkaline formulations should be avoided for systems which include galvanized materials of construction.

Closed hydronic systems connected to either a closed circuit cooler or dry cooler should be precleaned and flushed to remove debris, grease, flash rust, oil, and other suspended solids prior to operation. EVAPCO recommends the use of inhibitor chemistry or inhibited glycol to minimize corrosion and scale during normal operation. EVAPCO recommends a minimum of 25% inhibited glycol to minimize corrosion.

Recommended Maintenance Schedule

PROCEDURE	FREQUENCY
1. Clean pan strainer	Monthly or as needed
2. Clean and flush pan**	Quarterly or as needed
3. Check bleed-off valve to make sure it is operative	Monthly
4. Check operating level in pan and adjust float valve if necessary	Monthly
5. Check water distribution system and spray pattern	Monthly
6. Check drift eliminators	Quarterly
7. Check the fan blades for cracks, missing balancing weights, loose weight port caps, open drain holes (Super Low Sound Fans) and vibrations	Quarterly
8. Check sheaves, bushings, fan shafts and fan hubs for corrosion. Scrape and coat with ZRC	Annually
9. Inspect lubrication lines to bearings	Quarterly
10. Lubricate fan shaft bearings*	Every 1000 hours of operation (or every three months)
11. Check belt tension and adjust	Monthly
12. Sliding motor base – Inspect and grease	Annually or as needed
13. Check fan screens, inlet louvers and fans. Remove any dirt or debris	Monthly or as needed
14. Inspect and clean protective finish - Galvanized: scrape and coat with ZRC - Stainless: clean and polish with a stainless steel cleaner.	Annually
15. Check water quality for biological contamination. Clean unit as needed and contact a water treatment company for recommended water treatment program**	Regularly

OPTIONAL ACCESSORIES:

1. Gear Reducer – Check oil level with unit stopped	24 hours after startup & monthly
2. Gear Reducer/Piping – Do visual inspection for oil leaks, auditory inspection for unusual noises and vibrations	Monthly
3. Gear Reducer – Replace oil	Semiannually
4. Oil Pump – Do visual inspection for leaks and proper wiring	Monthly
5. Gear Reducer/Coupling – Check alignment of the system	24 hours after startup & monthly
6. Coupling/Shaft – Inspect flex elements and hardware for tightness, proper torque & crack/deterioration	Monthly
7. Heater Controller – Inspect controller and clean probe ends	Quarterly
8. Heater – Inspect junction box for loose wiring and moisture	One month after startup and semiannually

* See maintenance manual for startup instructions and lubrication recommendations.

** Cooling towers must be cleaned on a regular basis to prevent the growth of bacteria including Legionella Pneumophila.

Recommended Maintenance Schedule (Continued)

OPTIONAL ACCESSORIES:

9. Heater – Inspect elements for scale buildup	Quarterly
10. Electronic Water Level Controller – Inspect junction box for loose wiring and moisture	Semiannually
11. Electronic Water Level Controller – Clean probe ends of scale buildup	Quarterly or as needed
12. Electronic Water Level Controller – Clean inside the standpipe	Annually
13. Solenoid Makeup Valve – Inspect and clean valve and strainer of debris	As needed
14. Vibration Switch (mechanical) – Inspect enclosure for loose wiring and moisture	One month after startup and monthly
15. Vibration Switch – Adjust the sensitivity	During startup and annually
16. Sump Sweeper Piping – Inspect and clean piping of debris	Semiannually
17. Water Level Indicator – Inspect and clean	Annually

DURING IDLE PERIODS: Refer to recommendations on page 4.

Seasonal Shutdown Checklist

When the system is to be shut down for an extended period of time, the following services should be performed.

- 1. The evaporative cooling unit cold water basin should be drained.
- 2. The cold water basin should be flushed and cleaned with the suction strainer screens in place.
- 3. The suction strainer screens should be cleaned and reinstalled.
- 4. The cold water basin drain should be left open.
- 5. The fan shaft bearings and motor base adjusting screws should be lubricated. This should also be performed if the unit is going to sit idle prior to initial startup.
- 6. The makeup water supply, overflow and drain lines, as well as the recirculating pump and pump piping up to the overflow level, must be heat traced and insulated to account for any residual water.
- 7. The finish of the unit should be inspected. Clean and refinish as required.
- 8. The fan, motor, and pump bearings need to be turned at least once a month by hand. This can be accomplished by making sure the unit's disconnect is tagged and locked out, and grasping the fan assembly, rotating it several turns.
- 9. Energize fan motor space heaters.
- 10. CLOSED CIRCUIT COOLERS ONLY - EVAPCO is not responsible for ensuring that the product is adequately protected against the heat transfer fluid freezing. If the recommended minimum fluid flows through the heat transfer coil cannot be maintained, and an antifreeze solution is not in the coil, the coil must be drained immediately whenever the system pumps are shut down or flow stops during freezing conditions. This is accomplished by having automatic drain valves and air vents in the piping to and from the cooler.

NOTE: Opening the air vent and drain connections is not sufficient to fully drain the coil and prevent damage due to freezing. Pressurized air assist is required to fully drain the coil and prevent damage due to freezing.

Care must be taken to ensure that the piping is adequately insulated and sized to allow the water to flow quickly from the coil. This method of protection should be used only in emergency situations and is neither a practical nor recommended method of freeze protection. Coils should not be drained for an extended period of time, as internal corrosion may occur. See the "Cold Weather Operation" section of this document for more details.

See fan and pump manufacturer maintenance and long-term storage instructions for more detailed instructions.

Basic Closed Circuit Cooler/Condenser Sequence of Operation for Wet or Evaporative Mode

System Off / No Load

The system pumps and fans are off. If the basin is full of water a minimum basin water temperature of 40°F must be maintained to prevent freezing. This can be accomplished with the use of optional basin heaters. If provided, the starter interlock will energize any optional basin heaters in cold weather. See the "Cold Weather Operation" section of this bulletin for more details on cold weather operation and maintenance.

The recirculation pump should not be used as a means of capacity control, and should not be cycled frequently. Excessive cycling can lead to scale buildup, and reduce wet and dry performance.

System/Condensing Temperature Rises

The recirculation pump turns on. The unit will provide approximately 10% cooling capacity with only the pump running. If the unit has positive closure dampers they should be fully opened before the pumps turn on.

If the system temperature continues to rise, the unit fan is cycled on. For a variable speed controller, the fans are turned on to minimum speed. See the "Fan System – Capacity Control" section of this bulletin for more details on fan speed control options. If the system temperature continues to rise, then the fan speed is increased as required, up to full speed.

NOTE: *During subfreezing weather the minimum recommended speed for variable speed controllers is 50%. ALL FANS IN OPERATING CELLS OF MULTIPLE CELL UNITS MUST BE CONTROLLED TOGETHER TO PREVENT ICING ON THE FANS.*

System/Condensing Temperature Stabilizes

Control the leaving fluid temperature (closed circuit coolers) or condensing temperature (evaporative condensers) by modulating the fan speeds with variable speed drives or by cycling fans on and off with single or two-speed drives.

System/Condensing Temperature Drops

Decrease the fan speed, as required.

Dry Operation

During colder winter months it is possible to turn off the spray pump, drain the cold water basin, and just cycle the fans. Be sure to leave the basin drain open during this time to prevent collection of rain water, snow, etc. If the unit has positive closure dampers they should be fully opened before the fans turn on. If dry operation will be used on a centrifugal fan, forced draft unit, be sure to verify that the motor and drives have been properly sized to handle the reduction in static pressure experienced when the spray water is turned off.

NOTE: *Minimum control point for process fluid should never be lower than 42° F.*

NOTE: *When a unit is provided with a discharge damper assembly, the control sequence should cycle the dampers open and closed once a day regardless of capacity requirements to prevent the assembly from seizing. The fan motor should be shut off whenever the dampers are closed.*

NOTE: *ESW4 or PHC product lines should not operate dry.*

NOTE: *The eco-ATWB and eco-ATWB-H sequence of operation is unique and is explained in detail in the Sage® Control System manual.*

Fan System

The fan systems of both centrifugal and axial driven units are rugged; however, the fan system must be checked regularly and lubricated at the proper intervals. The following maintenance schedule is recommended.

Fan Motor Bearings

EVAPCO evaporative cooling units use either a TEAO (Totally Enclosed Air Over) or a TEFC (Totally Enclosed Fan Cooled) fan motor. These motors are built to “Cooling Tower Duty” specifications. They are supplied with permanently lubricated bearings and special moisture protection on the bearings, shaft and windings. After extended shutdowns, the motor should be checked with an insulation tester prior to restarting the motor.

Fan Shaft Ball Bearings

For induced draft units, lubricate the fan shaft bearings every 1,000 hours of operation or every three months. For forced draft units, lubricate the fan shaft bearings every 2,000 hours of operation or every six months. Use any of the following synthetic waterproof, polyurea inhibited greases which are suitable for operation between -20°F and 350°F. (for colder operating temperatures, contact the factory).

Mobil Polyrex™ EM

Chevron® SRI Grease

Timken® Ball Bearing Pillow Block Grease

Feed grease slowly into the bearings or the seals may be damaged. A hand grease gun is recommended for this process. When introducing new grease, all grease should be purged from the bearings.

Most EVAPCO units are supplied with extended grease lines to allow easy lubrication of the fan shaft bearings as shown in Table 1.

UNIT DESCRIPTION	LOCATION OF LUBE LINE FITTINGS
Induced Draft Units: 4', 7', 8', 8.5', 14' (ATWB), 17' wide	Located just beside the fan casing access door
Induced Draft Units: 10', 12', 14' (ESW4), 20', 24', 28' wide	Located inside the fan casing access door
Forced Draft Units	Located on the bearing support or on the side of the unit
PHW/PHC-E Units	Located inside access door at bottom of casing/ above the field seam

Table 1 — Location of Grease Lube Line Fittings for Belt Driven Units

Fan System (Continued)

Fan Belt Adjustment *(Direct drive units do not require any adjustment)*

The fan belt tension should be checked at startup and again after the first 24 hours of operation to correct for any initial stretch. To properly adjust the belt tension, position the fan motor so that the fan belt will deflect approximately 3/8" when moderate pressure is applied midway between the sheaves. Figure 1 and Figure 2 show two ways to measure this deflection. Belt tension should be checked on a monthly basis. A properly tensioned belt will not "chirp" or "squeal" when the fan motor is started.

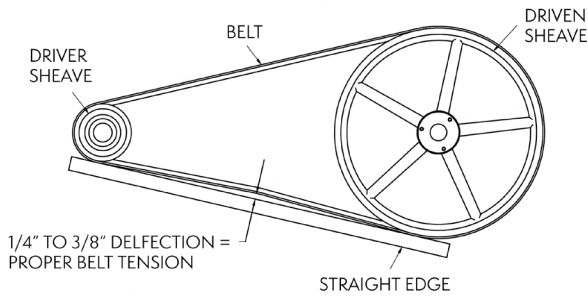

Figure 1 – Method 1

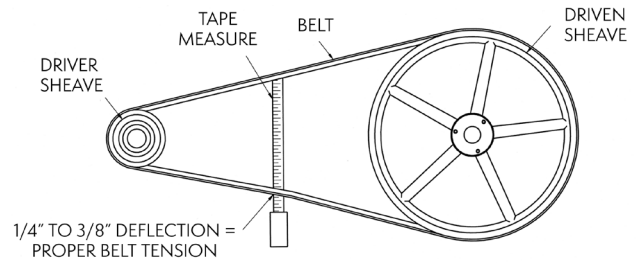

Figure 2 – Method 2

Induced Draft: On induced draft belt-driven units provided with externally mounted motors, see Figure 3.

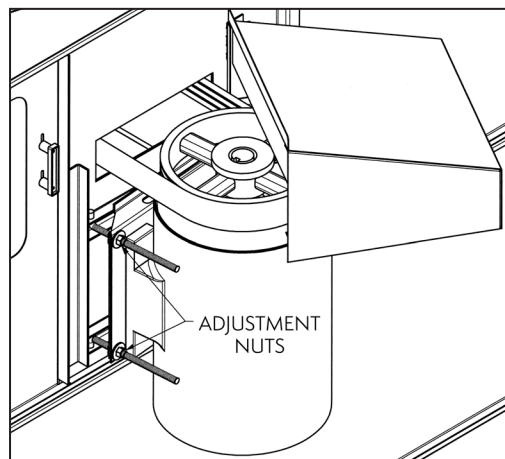

Figure 3 – Externally Mounted Motor, Induced Draft

Fan System (Continued)

On induced draft belt driven-units with internally mounted motors (10-, 12-, 14-, 20-, 24-, and 28-foot wide units). PHW, PHC-S and D units, a motor adjustment tool is provided on the adjustment nut. To use, place the hex end over the adjustment nut and tension the belt by turning the nut counterclockwise. When the belts are properly tensioned, tighten the lock nut.

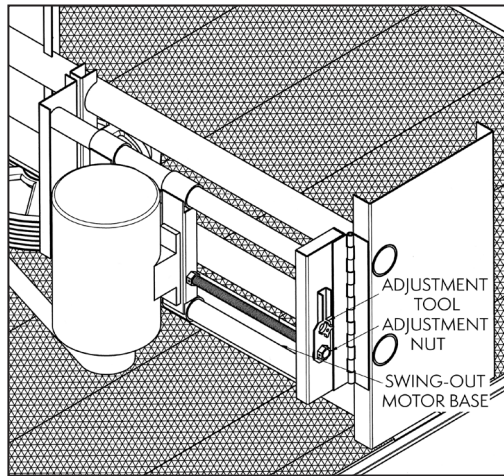

Figure 4 — Internally Mounted Motor, Induced Draft

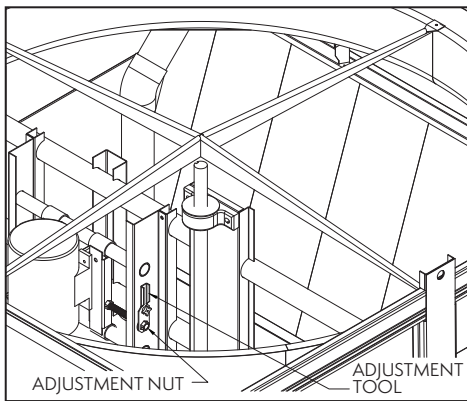

Figure 5 — Internally Mounted Motor, PHW/PHC-D Unit

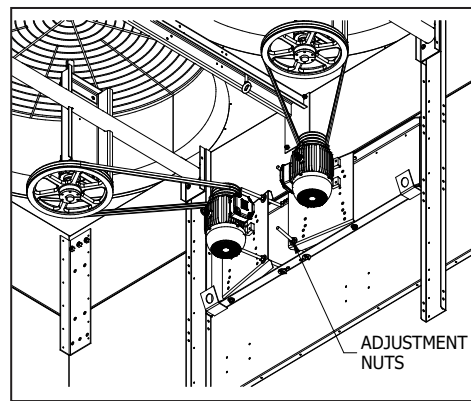

Figure 6 — Internally Mounted Motor, PHC-S Tandem Fan Units

Fan System (Continued)

Forced Draft: LS and PM Style forced draft units, both J-type adjustment bolts on the adjustable motor base should have an equal amount of exposed thread for proper sheave and belt alignment.

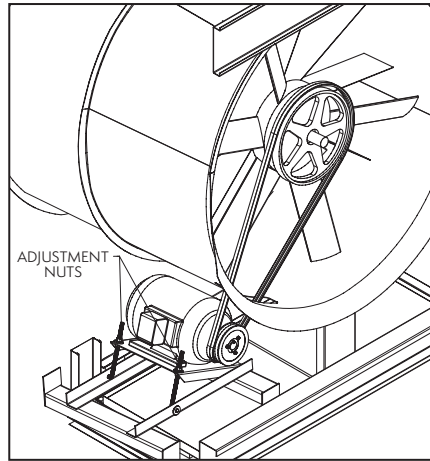

Figure 7 – PM Style Motor Adjustment

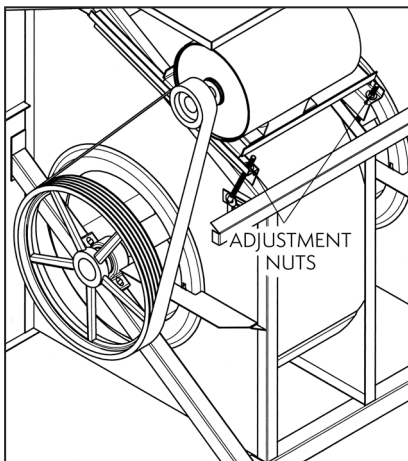

Figure 8a — Externally Mounted Motor, Large LS, 8X & 3M Units

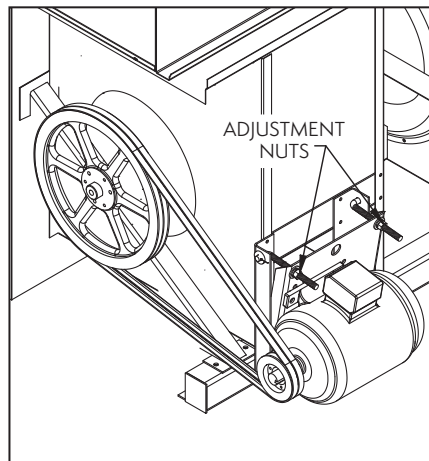

Figure 8b — Externally Mounted Motor, Small LS, 4X & 5X Units

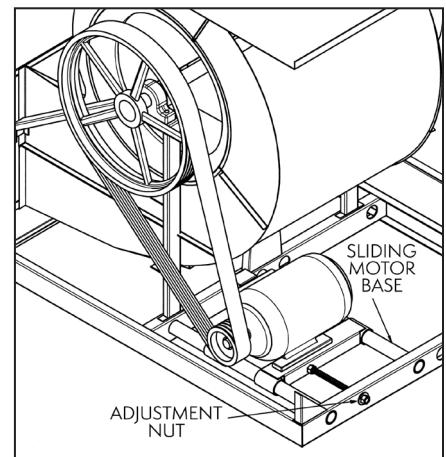

Figure 9 — LR Motor Adjustment

Gear Drives

Induced draft units with gear drive systems require special maintenance. Please refer to the gear manufacturer's recommended maintenance instructions. These will be enclosed and shipped with the unit.

Air Inlet

Inspect the air inlet louvers (induced draft units) or fan screens (forced draft units) monthly to remove any paper, leaves or other debris that may be blocking airflow into the unit.

Coil Inlet

Inspect the top coil, air inlet, and spray section on all PHW/PHC units monthly.

Fan System - Capacity Control

There are several methods for capacity control of the evaporative cooling unit. Methods include: fan motor cycling, the use of two speed motors, and the use of variable frequency drives (VFDs).

NOTE: For the eco-ATWB series of closed circuit coolers with Sage® Control System, consult the manual.

Fan Motor Cycling

Fan motor cycling requires the use of a single stage thermostat which senses the fluid temperature (closed circuit coolers) or condensing temperature (evaporative condensers). The contacts of the thermostat are wired in series with the fan motor's starter holding coil. For individual fan motor cyclings, interlock fan motors before fan start to prevent issues with reversing idle fans.

Sequence of Operation for Fan Motor Cycling

Fan motor cycling is often found to be inadequate where the load has a wide fluctuation. In this method, there are only two stable levels of performance: 100% of capacity when the fan is on, and approximately 10% of capacity when the fan is off. Please note that rapid cycling of the fan motors can cause the fan motor to overheat. Controls should be set to only allow a maximum of six start/stop cycles per hour. The recirculation pump may not be used as a means of capacity control and should not be cycled frequently. Excessive cycling can lead to scale buildup, resulting in reduced wet and dry performance.

Variable Frequency Drives

The use of a variable frequency drive (VFD) provides the most precise method of capacity control. A VFD is a device that converts a fixed AC voltage and frequency into an adjustable AC voltage and frequency used to control the speed of an AC motor. By adjusting the voltage and frequency, the AC induction motor can operate at many different speeds.

The use of VFD technology can benefit the life of the mechanical components with fewer and smoother motor starts and built-in motor diagnostics. VFD technology has particular benefit on evaporative cooling units operating in cold climates where airflow can be modulated to minimize icing and reversed at low speed for de-icing cycles. Applications using a VFD for capacity control must also use an inverter-capable motor built in compliance with NEMA standard MG-1.

NOTE: VFDs should not be used on pump motors. The pumps are designed to be operated at full speed and are not intended to be used as capacity control.

The type of motor, manufacturer of the VFD, motor lead lengths (between the motor and the VFD), conduit runs and grounding can dramatically affect the response and life of the motor. Select a high quality VFD that is compatible with the fan motor(s) in the EVAPCO unit(s). Many variables in the VFD configuration and installation can affect motor and VFD performance. Two particularly important parameters to consider when choosing and installing a VFD are switching frequency and the distance between the motor and VFD often referred to as lead length. Consult the VFD manufacturer's recommendations for proper installation and configuration. The motor lead length restrictions can vary with the vendor. Regardless of motor supplier, minimizing lead length between the motor and drive is good practice.

VFD Lockout Notification

Sequence of Operations / Guidelines for Multi-fan Units with a VFD during Peak Load

For eco-ATWB and eco-ATWB-H, see Sage® Control Panel O&M

1. Both fan motors off – Pump running on one cell.
2. Both fan motors off – Pump running on both cells.
3. Both VFDs turn on at the manufacturer's recommended minimum operating speed (20%) – Pump running on both cells.
4. Both VFDs speed up uniformly (they should be synchronized on startup) – Pump running on both cells.
5. Both VFDs are on full speed – Pump running on both cells.

NOTE: The VFDs need to have a preset shutoff to prevent water temperatures from becoming too cold and to prevent the drive from trying to turn the fan at near zero speed. Operating below 20% of motor speed achieves very little return in fan energy savings and capacity control. Check with your VFD supplier if operating below 20% is possible.

Fan System - Capacity Control (Continued)

Variable Frequency Drive Lockout Notification



Qualified personnel should use proper care, procedures and tools when maintaining the fan/drive system in order to prevent personal injury and/or property damage.



Identify and lock out harmful resonant frequencies.

A variable frequency drive (VFD) fan system, unlike traditional fixed-speed systems, is designed to operate between 20% (12Hz) and 100% (60Hz) speeds, which creates an opportunity for operation where resonant frequencies exist. Sustained operation at resonant frequencies may lead to excessive vibration, fatigue of structural components, and/or drive system noise and failure. Owners and operators must anticipate the existence of resonant frequencies and lockout frequencies during startup and commissioning in order to prevent drive system operational problems and structural damage. As a part of the normal startup and commission processes, resonant frequencies should be identified and locked out in the VFD's software.

The unit's supporting structure, external piping, and accessories contribute to the overall harmonic makeup and stiffness of the system. The choice of VFD will also have a significant influence on how the system behaves. Consequently, not all resonant frequencies can be determined in advance at the manufacturer's factory during final inspection and testing. Relevant resonant frequencies (if they occur) can only be identified accurately after the unit installation in the system.

To check for resonant frequencies in the field, a run-up and run-down test must be performed. Additionally, VFD carrier frequencies should be adjusted to best align the VFD with the electrical system. Refer to your drive's startup procedures for additional information and instruction.

The procedure of checking for resonant frequencies requires stepping through the VFD's operating range at (2) Hz intervals from the lowest operating frequency to full speed. At each step, pause long enough for the fan to reach steady-state. Note changes in unit vibration during this time. Repeat from full speed to minimum speed. Should vibration-inducing frequencies exist, the run-up and run-down test will isolate the resonant frequencies which then must then be locked out in the VFD programming.

For more details on the use of variable frequency drives, please download a copy of EVAPCO's Engineering Bulletin 39 from evapco.com.

Two-Speed Motors

The use of a two-speed motor provides an additional step of capacity control when used with the fan cycling method. The low speed of the motor will provide approximately 60% of full speed capacity.

Two-speed capacity control systems require not only a two-speed motor, but also a two-stage thermostat and the proper two-speed motor starter. The most common two-speed motor is a single winding type. This is also known as a consequent pole design. Two-speed two-winding motors are also available. All multi-speed motors used in evaporative cooling units should be variable torque design.

NOTE: When two-speed motors are to be used, the motor starter controls must be equipped with a decelerating time delay relay. The time delay should be a minimum of 30 seconds when switching from high speed to low speed.

Sequence of Operation for Two Cell Units with Two Speed Motors during Peak Load

For the eco-ATWB and/or eco-ATWB-H, see Sage® Control System O&M.

1. Both fan motors off – Pump running on one cell.
2. Both fan motors off – Pump running on both cells.
3. One fan motor on low speed, one fan motor off – Pump running on both cells.
4. Both fan motors on low speed – Pump running on both cells.
5. One fan motor on high speed, one fan motor on low speed – Pump running on both cells.
6. Both fan motors on full speed – Pump running on both cells.

Recirculated Water System - Routine Maintenance

Suction Strainer in Cold Water Basin

The pan strainer as shown in Figures 10 through 14 should be removed and cleaned monthly or as often as necessary. The suction strainer is the first line of defense in keeping debris out of the system. Make certain that the strainer is properly located over the pump suction, alongside the anti-vortexing hood.

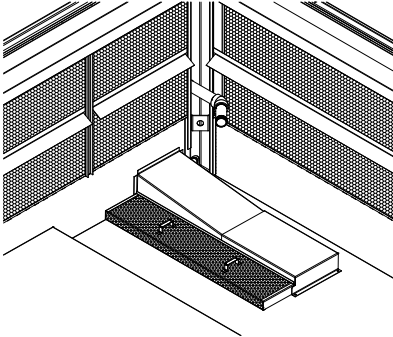

Figure 10 — ATC/ATWB Strainer Assembly

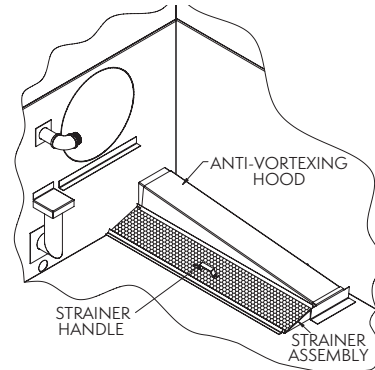

Figure 11 — LSWE/LSC-E/PMC-E Strainer Assembly

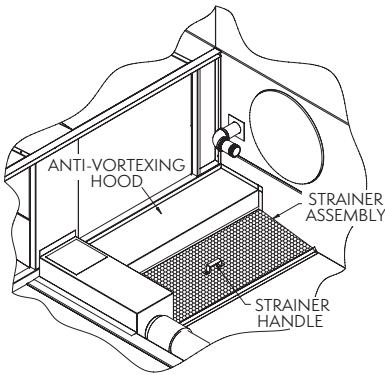

Figure 12 — LRWB/LRC Strainer Assembly

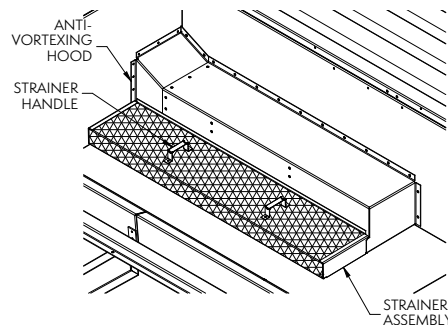

Figure 13 — PHC-S/PMRC Strainer Assembly

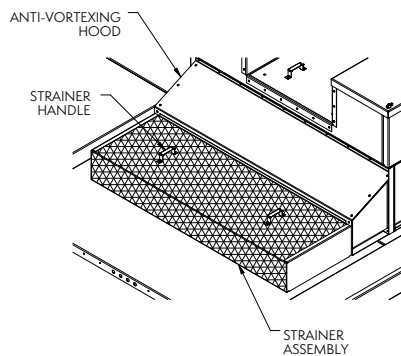

Figure 14 — PHW/PHC-D Strainer Assembly

Recirculated Water System - Routine Maintenance (Continued)

Cold Water Basin

The cold water basin should be checked monthly (or more often, if necessary) and flushed out quarterly to remove any accumulation of dirt or sediment which normally collects in the basin. Sediment can become corrosive and cause deterioration of basin materials. When flushing the basin, it is important to keep the suction strainers in place to prevent any sediment from entering the system. After the basin has been cleaned, the strainers should be removed and cleaned before refilling the basin with fresh water.

Operating Level of Water in Cold Water Basin

The operating level should be checked monthly to make sure the water level is correct. Refer to Table 2 for unit specific levels.

EVAPORATIVE CONDENSERS	CLOSED CIRCUIT COOLERS	OPERATING WATER LEVEL*
ATC-E Products 50E to 165E 170E to 3714E	ATWB & eco-ATWB Products 4' wide units 7' wide to 24' wide units	9" 11"
eco-ATC Products 122A to 3846A	—	11"
eco-ATC-H 8.5' wide to 24' wide units	eco-ATWB-H 8.5' wide to 24' wide units	11"
LRC Products 25 to 379	LRWB & eco-LRWB Products 3' wide to 8' wide units	8"
LSC-E Products 36 to 170 185 to 385 400 to 515, 800 to 1030 550 to 805, 1100 to 1610 PMC-E, PMRC, eco-PMC & eco-PMRC 175E to 375E, 183 to 387 332E to 2019E, 275 to 2191	LSWE & eco-LSWE Products 4'x6' to 4'x12' 5.5'x12', 5.5'x18' 8'x12', 8'x24', 10'x12', 10'x24' 8'x18', 8'x36', 10'x18', 10'x36'	11" 11" 12" 15" 10" 14"
—	ESW4 Products 8.5' and 14' wide units 12' wide unit	9" 10"
—	PHW Products 12' and 14' wide units	11"

*Measured from lowest point on basin floor.

Table 2 — Recommended Operating Water Level

At initial startup or after the unit has been drained, the unit must be filled to the overflow level. Overflow is above the normal operating level and accommodates the volume of water normally in suspension in the water distribution system and the riser piping.

The water level should always be above the strainer. Check by running the pump with the fan motors off and observing the water level through the access door or remove the air inlet louver.

Recirculated Water System - Routine Maintenance (Continued)

Water Makeup Valve

A mechanical float valve assembly is provided as standard equipment on the evaporative cooling unit (unless the unit has been ordered with an optional electronic water level control package or the unit is arranged for remote sump operation). The makeup valve is easily accessible from outside the unit through the access door or removable air inlet louver. The makeup valve is a bronze valve connected to a float arm assembly and is activated by a large foam filled plastic float. The float is mounted on an all-thread rod held in place by wing nuts. The water level in the basin is adjusted by repositioning the float and all-thread using the wing nuts. Refer to Figure 15 for details.

After initial startup or after the unit has been drained, the unit must be filled to the overflow level. Overflow is above the normal operating level and accommodates the volume of water normally in suspension in the water distribution system and the riser piping.

The makeup valve assembly should be inspected monthly and adjusted as required. The valve should be inspected annually for leakage and if necessary, the valve seat should be replaced. The makeup water pressure for the mechanical valve should be maintained between 20 and 50 PSIG.

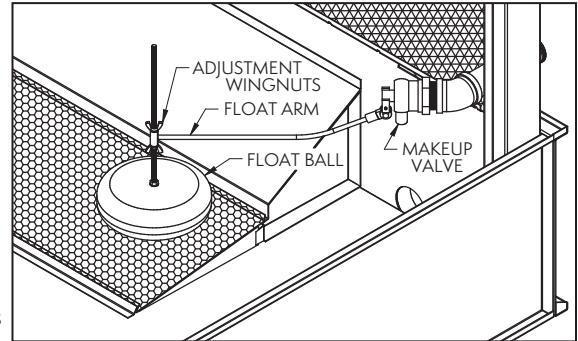

Figure 15 – Mechanical Water Makeup Valve

Pressurized Water Distribution Systems

Check the water distribution system monthly to make sure it is operating properly. Always check the spray system with the pump on and the fans off. On forced draft models, remove one or two eliminator sections from the top of the unit and observe the operation of the water distribution system. On induced draft models, lifting handles are provided along the top layer of eliminators. Eliminators can be easily removed from the access door and the distribution system observed. The diffusers are essentially non-clogging and should seldom need cleaning or maintenance.

If the water diffusers are not functioning properly, it is a sign that the pan or system strainer has not been working properly and that foreign matter or dirt has accumulated in the water distribution pipes. The nozzles can be cleared by taking a small pointed probe and moving it rapidly back and forth in the diffuser opening.

If an extreme buildup of dirt or foreign matter occurs, remove the end cap in each branch to flush the debris from the header pipe. The branches or header can be removed for cleaning, but do so only if necessary. Check the strainer in the pan to make sure it is in good condition and positioned properly so that cavitation or air entrainment does not occur.

All evaporative condensers and closed circuit coolers, except the ESW4 closed circuit coolers, are supplied with ZMII® spray nozzles as standard. The ZMII® spray nozzles do not need to be oriented a specific way to achieve proper coil coverage. Figure 16 shows the standard orientation of the ZMII® spray nozzles.

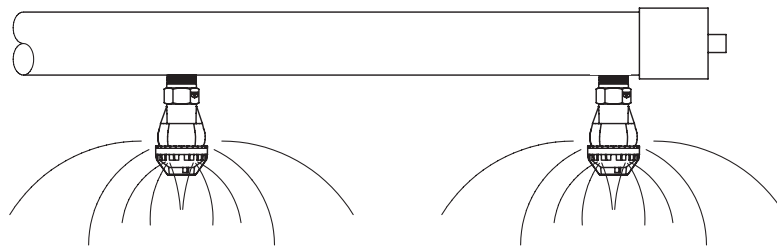

Figure 16 – ZMII® Spray Nozzle Orientation
All Coil Products except the ESW4

Recirculated Water System - Routine Maintenance (Continued)

For the ESW4, wide orifice water diffusers are supplied, shown in Figure 17. When inspecting and cleaning the water distribution system, always check that the orientation of the water diffusers is correct as shown in Figures 17 and 18. For EvapJet® nozzles, make sure that the top edge of the EVAPCO logo is parallel to the top of the water distribution pipe.

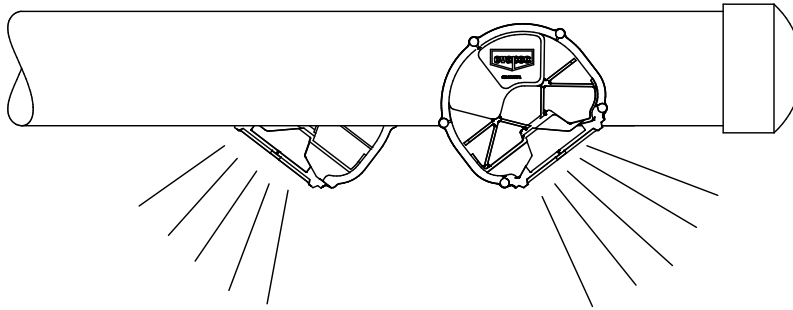

Figure 17 – Proper Water Diffuser Orientation (EvapJet®)
ESW4 Models Only

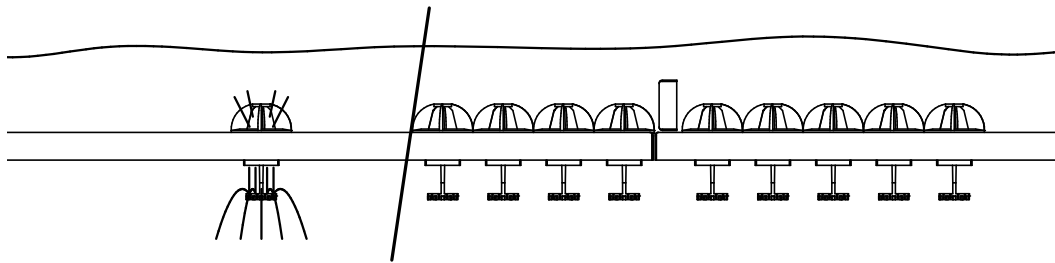

Figure 18 – Gravity Fed Distribution Pan
ESW4 Models Only

Bleed-Off Valve

The bleed-off valve, whether factory or field installed, must be checked weekly to make sure it is functioning and set properly. Additional information can be found under “Water Treatment and Water Chemistry”.

Pump (When Supplied)

The pump and pump motor should be lubricated and serviced in accordance with the pump manufacturer’s instructions as supplied with the unit. The recirculation pump should not be used as a means of capacity control, used with a VFD or be cycled frequently. Excessive cycling can lead to scale buildup, and reduce wet and dry performance. On ESW4 units supplied with two pumps per cell, both pumps should be energized at the same time. One pump should not be on while the other pump is off.

The pump motor shaft and impeller should be turned by hand if the pump assembly sits idle (for a month or more).

Disconnect the power and lock out/tag out the pump disconnect. Remove the pump motor fan guard and rotate the pump fan/shaft several turns by hand. Reassemble the fan guard and return to service.

NOTE: For the eco-ATWB and eco-ATWB-H, please consult the Sage® Control System manual.

Water Treatment and Water Chemistry

Proper water treatment is an essential part of the maintenance required for evaporative cooling equipment. A well designed and consistently implemented water treatment program will help to ensure efficient system operation while maximizing the equipment's service life. A qualified water treatment company should design a site-specific water treatment protocol based on equipment including all metallurgies in the cooling system, location, makeup water quality, and usage.

Water Chemistry Parameters

The water treatment protocol for evaporative cooling equipment must be compatible with all the unit's materials of construction including metallurgies, components, and connected equipment. Control of corrosion and scale will be difficult if the recirculating water chemistry is not consistently maintained within the ranges noted in Table 3. In mixed metallurgy systems, the water treatment program should be designed to ensure protection of all the components including the evaporative equipment, interconnecting piping, heat exchanger(s), and ancillary components.

PROPERTY	G-235 GALVANIZED STEEL	TYPE 304 STAINLESS STEEL	TYPE 316 STAINLESS STEEL
pH	7.0 – 8.8	6.0 – 9.5	6.0 – 9.5
pH during Passivation	7.0 – 8.0	N/A	N/A
Total Suspended Solids (ppm)*	< 25	< 25	< 25
Conductivity (µmhos/cm) **	< 2,400	< 4,000	< 5,000
Alkalinity as CaCO ₃ (ppm)	75 - 400	< 600	< 600
Calcium Hardness CaCO ₃ (ppm)	50 - 500	< 600	< 600
Chlorides as Cl (ppm) ***	< 300	< 500	< 2,000
Silica (ppm)	< 150	< 150	< 150
Total Bacteria (cfu/ml)	< 10,000	< 10,000	< 10,000

* Based on standard EVAPAK® fill

** Based on clean metal surfaces. Accumulations of dirt, deposits, or sludge will increase corrosion potential

*** Based on maximum coil fluid temperatures below 120°F (49°C)

Table 3 – Recommended Water Chemistry Guidelines

Acid

EVAPCO does not recommend the on-going use of acid, following any required passivation, due to the destructive consequences of improper feed or control. If acid is used as part of a site-specific treatment program, it should be prediluted prior to introduction into the cooling water and fed by automated equipment into an area of the system which ensures adequate mixing. The location of the pH probe and acid injection point should be designed in conjunction with the automated controller to ensure that proper pH levels are consistently maintained throughout the cooling water system. The automated system should be capable of storing and reporting data including pH levels and chemical feed pump status. Automated pH control systems require frequent calibration by plant personnel to ensure proper operation and to protect the evaporative cooling system from increased corrosion potential.

Air Contamination

Evaporative cooling equipment draws in air as part of normal operation and can scrub particulates out of the air. Do not locate the unit next to smokestacks, discharge ducts, vents, flue gas exhausts, etc. because the unit will draw in these fumes which may lead to accelerated corrosion or deposition potential within the unit. Additionally, it is important to locate the unit away from the building's fresh air intakes to prevent any drift, biological activity, or other unit discharge from entering the building's air system.

Water Treatment and Water Chemistry (Continued)

Bleed or Blowdown

Evaporative cooling equipment rejects heat by evaporating a portion of the recirculated water into the atmosphere as warm, saturated discharge air. As the pure water evaporates, it leaves behind the impurities (TDS) found in the system's makeup water and any accumulated airborne contaminants (TSS). These impurities and contaminants, which continue to recirculate in the system, must be controlled to avoid excessive concentration which can lead to corrosion, scale, or biological fouling.

Evaporative cooling equipment requires a bleed or blowdown line to remove concentrated (up) water from the system. For any chemically treated system, the bleed or blowdown line should be piped to a sanitary sewer or on-site water treatment plant. EVAPCO recommends an automated conductivity controller to maximize the water efficiency of your system.

Control of Biological Contamination

Building water systems receive potable and non-potable water from either a public or private entity for their water supply. This water supply for building water systems can contain various waterborne pathogens, including Legionella bacteria, which can cause or contribute to various illnesses if aspirated, ingested, or inhaled. Since evaporative cooling equipment uses the same building water, there is some potential that these pathogens, including Legionella, might propagate in the piping or equipment. As such, evaporative cooling equipment should be located at such a distance and wind direction to minimize the possibility of tower discharge air and associated drift being drawn into building fresh air intakes or near areas frequented by at-risk individuals. Purchasers should obtain the services of a licensed professional engineer or a registered architect to certify that the location of the evaporative cooling equipment is in compliance with acceptable building, fire, and clean air codes. (See EVAPCO's Equipment Layout Manual for more information.)

In addition, it is recommended that the building employ a site-specific water management program that is designed to minimize the risk of Legionellosis associated with building water systems (See ANSI/ASHRAE Standard 188-2021).

During operation, both monitoring of total planktonic bacteria populations and visual inspections for evidence of biofouling should be included in the water management program. Off-line cleaning and inspection of evaporative cooling equipment should be undertaken on a regular basis. Additionally, routine inspection and maintenance of the drift eliminators should be included in the water management plan. Service personnel performing the inspections and maintenance should be familiar with, and follow, personal protective equipment (PPE) guidance and best practices including OSHA 29 CFR 1910.132 and others.

Galvanized Steel – Passivation

'White Rust' is a premature corrosion of the protective zinc layer on hot dip or mill galvanized steel which can occur if proper water quality and treatment control are not maintained during the first several weeks of wet operation. Planning a site-specific passivation program prior to startup and wet operation is the best way to help ensure full-service life for new galvanized equipment.

EVAPCO recommends that your site-specific water treatment program include a passivation procedure which details the site's makeup water quality, feed and control strategy for any necessary chemical addition, service and testing frequency, along with visual and photographic inspections during the first six (6) to twelve (12) weeks of wet operation.

For more information on passivation and white rust, please search 'White Rust' at evapco.com to review Engineering Bulletin 36A.

Water Treatment and Water Chemistry (Continued)

Gray Water and Reclaimed Water

The use of water reclaimed from another process as a source of makeup water for evaporative cooling equipment may be considered if the water quality is reviewed by the water treatment vendor and determined to be consistent in terms of the quality supplied. The use of Gray or Reclaimed water can increase the potential of corrosion, microbiological amplification, and scale formation compared to municipal or potable makeup water. EVAPCO recommends that an extra safety factor be applied to the values noted in Table 4 when Gray or Reclaimed water is used due to variability in alkalinity, ammonia, hardness, oxidizing biocides, and phosphates.

Soft Water

Makeup water low in calcium hardness and magnesium hardness may occur naturally or through a pretreatment process such as sodium zeolite softening. Naturally soft, or softened, makeup water increases the potential for corrosion in the cooling water system and on other metal surfaces adjacent to the evaporative cooling equipment.

Soft water makeup is not appropriate for evaporative cooling systems which include galvanized materials of construction. Equipment manufacturers, including EVAPCO, recommend that a minimum of 30- to 50-ppm (as CaCO_3) be maintained in the recirculating water when these materials of construction are present.

In addition to calcium hardness, any water treatment program seeking to increase operating cycles of concentration using soft water should pay close attention to cycled alkalinity, chloride, pH, and silica values. Lower maximum values than those provided in Table 3 may need to be maintained to avoid damage to the evaporative cooling system, heat exchanger(s), and adjacent steel surfaces.

Cold Weather Operation

EVAPCO counterflow evaporative cooling equipment is well suited to operate in cold weather conditions. The counterflow design encases the heat transfer media (fill and/or coils) completely, and protects it from the outside elements such as wind which can cause freezing in the unit.

When the evaporative cooling unit is going to be used during cold weather conditions, several items need to be considered including unit layout, recirculating water, unit recirculating piping, unit heat transfer coils, unit accessories, and capacity control of the units.

Unit Layout

Adequate unobstructed air flow must be provided for both the intake and discharge from the unit. It is imperative that the equipment minimize the risk of recirculation. Recirculation can result in condensation freezing the inlet louvers, fans, and fan screens. The buildup of ice on these areas can adversely affect air flow and in more severe cases, lead to failure of these components. Prevailing winds can create icing conditions on the inlet louvers and fan screens adversely affecting airflow to the unit.

For additional information on unit layout, please refer to EVAPCO's Equipment Layout Manual.

Freeze Protection of Recirculating Water

The simplest and most effective way of keeping the recirculated water from freezing is to use a remote sump. With a remote sump, the recirculating water pump is mounted remotely at the sump and whenever the pump is shut off, all recirculating water drains back to the sump. Recommendations for sizing the remote sump tank and recirculating water pumps for coil products are presented for evaporative condensers and closed circuit coolers in their respective catalog bulletin(s). The pressure drop through the water distribution system measured at the water inlet is as follows in Table 4.

If a remote sump cannot be used, basin heaters are available to keep the recirculating water from freezing when the pump is turned off. Electric heaters, hot water coils, steam coils or steam injectors may be used to heat the basin water when the unit is shut down. However, the basin heater will not prevent the external water lines, pump or pump piping from freezing. The makeup water supply, overflow and drain lines, as well as the pump and pump piping up to the overflow level, must be heat traced and insulated to protect them from damage. Any other connections or accessories at or below the water level, such as electronic water level controllers, must also be heat traced and insulated.

A condenser or cooler cannot be operated dry (fans on, pump off) unless the water is completely drained from the pan. The pan heaters are sized to prevent pan water from freezing only when the unit is completely shut down.

NOTE: *Using basin heaters will not prevent the fluid in the coils, nor the residual water in the pump or pump piping from freezing.*

Cold Weather Operation (Continued)

EVAPORATIVE CONDENSER MODEL NO.		CLOSED CIRCUIT COOLER FOOTPRINT	REQ'D INLET PRESS. (psi)
ATC-E Products 4' wide units 7x 8', 12', 14', 24', 28' 7'x18', 7'x36' 7' x 8.5' 8.5' x 9' 8.5'x10.5', 12', 14' 8.5' x 18' 8.5' x 21' 8.5'x 24', 8.5'x 28' 17'x 12', 17'x 14' 10'x 12', 10'x 24' 10'x 18', 10'x 36' 12'x 12', 14', 18' 12'x 24', 28', 36' 24'x 12', 14', 18' 24'x 24', 28', 36' 12'x 20', 12'x 40' 24'x 20', 24'x 40'	eco-ATC-A Products 4' wide units 7x 8', 12', 14', 24', 28' 7'x 18', 7'x 36' 7' x 8.5' 8.5' x 9' 8.5'x 10.5', 12', 14' 8.5' x 18' 8.5' x 21' 8.5'x 24', 8.5'x 28' 17'x 12', 17'x 14' 10'x 12', 10'x 24' 10'x 18', 10'x 36' 12'x 12', 14', 18' 12'x 24', 28', 36' 24'x 12', 14', 18' 24'x 24', 28', 36' 12'x 20', 12'x 40' 24'x 20', 24'x 40'	ATWB, eco-ATWB, & eco-ATWB-H Products 4' wide units* 7'x9', 12', 14', 24', 28'* 7'x18', 7'x36'* 7.5'x8.5' 8.5'x9' 8.5'x10.5', 8.5'x12', 8.5'x14' 8.5'x18' 8.5'x21' 8.5'x24', 28' 17'x12', 17'x14' 10'x12', 10'x24', 20'x12' 10'x18', 10'x36', 20'x18' 12'x12', 12'x14', 12'x18' 12'x24', 12'x28', 12'x36' 24'x12, 24'x14', 24'x18' 24'x24', 24'x28', 24'x36' 12'x20', 12'x40' 24'x20', 24'x40'	2.0 2.0 3.0 2.5 3.0 2.5 3.6 4.2 2.5 2.5 3.7 5.7 2.5 2.5 2.5 2.5 3.2 3.2
LRC Products 3' wide units 5'x 12' 5'x 15' 5'x 18' 8' wide units		LRWB & eco-LRWB Products 3' wide units 5'x6' 5'x9' 5'x12' 8' wide units	1.0 2.0 2.0 2.0 2.0
LSC-E Products 4'x 6' 4'x 9' 4'x 12', 4'x 18' 5.5'x 12', 5.5'x 18' 10'x 12', 18', 24', 36' 8'x 12', 18', 24', 36'		LSWE & eco-LSWE Products 4'x6' 4'x9' 4'x12', 4'x18' 5.5'x12', 5.5'x18' 10'x12', 10'x18', 10'x24', 10'x36' 8'x12', 8'x18', 8'x24', 8'x36'	1.5 1.5 1.5 2.0 2.5 3.0
-		ESW4 Products 8.5'x6' 8.5'x9' 8.5'x12' 8.5'x18' 12'x12' 12'x18' 14'x22'	3.0 2.5 2.5 3.0 2.0 3.0 2.0
PMC-E & PMRC & eco-PMC & eco-PMRC Products 6' wide units 10' wide units 12' wide units		-	2.0 4.0 3.5
PHC-E Products 7'x 9' 7'x 12' 7'x 18' 8.5'x 6' 8.5'x 9' 8.5'x 12' 8.5'x 18' 10'x 12' 10'x 18' 12'x 12' 12'x 18' 12'x 24' (multi-fan) 12'x 36' 12'x 24', 24'x 24' 14'x 26', 28'x 26'		PHW Products 12'x24' 14'x26'	3.5 4.0 3.5 4.0 3.5 4.0 3.5 2.0 2.5 3.0 4.0 3.0 4.0 4.0 5.5 5.5

NOTE: For multi-cell units, the inlet pressure shown is per cell.

*Not available as eco-ATWB-H

Table 4 — Required Recirculating Water Inlet Pressure for Remote Sump Application - Coil Products Only

Cold Weather Operation (Continued)

Freeze Protection of Closed Circuit Cooler Coils

EVAPCO is not responsible for ensuring that the product is adequately protected against the heat transfer fluid freezing. The simplest and most effective way of protecting the heat exchanger coil from freezing is to use an inhibited ethylene or propylene glycol antifreeze. If this is not possible, an auxiliary heat load and minimum flow rate must be maintained on the coil at all times so that the water temperature does not drop below 50°F when the cooler is shut down. See Table 5 for recommended minimum flow rates.

If an antifreeze solution is not used, the coil must be drained immediately whenever the pumps are shut down or flow stops. This is accomplished by having automatic drain valves and air vents in the piping to and from the cooler.

NOTE: *Opening the air vent and drain connections is not sufficient to fully drain the coil and prevent damage due to freezing. Pressurized air assist is required to fully drain the coil and prevent damage due to freezing.*

Care must be taken to ensure that the piping is adequately insulated and sized to allow the water to flow quickly from the coil. This method of protection should be used only in emergency situations and is neither a practical nor recommended method of freeze protection. Coils should not be drained for an extended period of time, as internal corrosion may occur.

When the unit is in operation during freezing weather, some type of capacity control is normally required in order to keep water temperatures from dropping below 50°F. Operating dry with a remote sump is an excellent way of reducing unit capacity at low temperatures. Other methods of capacity control include two-speed motors, VFDs, and fan cycling. These can be used individually or in combination with dry/remote sump operation.

CLOSED CIRCUIT COOLER FOOTPRINT	MINIMUM FLOWS	
	STANDARD FLOW GPM	SERIES FLOW GPM
eco-ATWB & eco-ATWB-H, ATWB Products		
4' wide units*	74	37
7' wide units*	140	70
7.5'x8.5'	148	74
8.5'x9' to 8.5'x21'	160	80
17'x12', 17'x14'	320	160
10'x12', 10'x18'	188	94
10'x24, 10'x36', 20'x12', 20'x18'	376	188
20'x24', 20'x36'	752	376
12'x12', 12'x14', 12'x18', 12'x20'	232	116
12'x24', 12'x28', 12'x36', 12'x40'	464	232
24'x12', 24'x14', 24'x18', 24'x20'	464	232
24'x24', 24'x28', 24'x36', 24'x40'	928	464
LRWB Products		
3' wide units	60	30
5' wide units	94	47
8' wide units	148	74
LSWE Products		
4'x6', 4'x9', 4'x12', 4'x18'	66	30
5.5'x12', 5.5'x18'	94	47
8'x12', 8'x18'	148	74
8'x24', 8'x36'	296	148
10'x12', 10'x18'	188	94
10'x24, 10'x36'	376	188
ESW4 Products		
8.5'x6'-LP	100	50
8.5'x9', 8.5'x12', 12'x12'-LP, 12'x12'-SP	160	80
8.5'x18', 12'x12'-LF, 12'x12'-SF, 12'x18'-LF, 12'x18'-X-SF	240	120
12'x18'-X-LP, 12'x18'-X-SP	320	160
12'x18'-X-LF, 12'x18'-X-SF	480	240
14'x22'	440	220
PHW Products		
12'x24'	700	350
14'x26'	820	410

*Not available as eco-ATWB-H

Table 5 — Closed Circuit Cooler Minimum Recommended Flow Rate

Cold Weather Operation (Continued)

Unit Accessories

The appropriate accessories to prevent or minimize ice formation during cold weather operation are relatively simple and inexpensive. These accessories include cold water basin heaters, the use of a remote sump, electric water level control, and vibration cutout switches. Each of these optional accessories ensures that the cooler or condenser will function properly during cold weather operation.

Cold Water Basin Heaters

Optional basin heaters can be furnished with the unit to prevent the water from freezing in the basin when the unit is idle during low ambient conditions. The basin heaters are designed to maintain 40°F basin water temperature at a 0°F ambient temperature. The heaters are only energized when the recirculating pumps are off and no water is flowing over the heat exchanger coil. As long as there is a heat load and water is flowing over the heat exchanger coil, the heaters do not need to operate. Other types of basin heaters to consider would include: hot water coils, steam coils, or steam injectors.

Remote Sumps

A remote sump located in an indoor heated space is an excellent way to prevent freezing in the cold water basin during idle or no load conditions because the basin and associated piping will drain by gravity whenever the recirculating pump is idle. EVAPCO units built for remote sump operation do not include recirculating water pumps.

Electric Water Level Control (EWLC)

Optional electric water level control packages can be furnished to replace the standard mechanical float and valve assembly. The makeup water pressure for electronic water level control should be maintained between 5 and 125 psig. The electric water level control eliminates the freezing problems experienced by the mechanical float. In addition, it provides accurate control of the basin water level and does not require field adjustment even under varying load conditions.

NOTE: *The standpipe assembly, makeup piping, and solenoid valve must be heat traced and insulated to prevent them from freezing.*

Vibration Cutout Switches

During severe cold weather conditions, ice can form on the fans of cooling towers causing excessive vibration. The optional vibration switch shuts the fan off avoiding potential damage to or failure of the drive system.

Capacity Control Methods for Cold Weather Operation

Induced draft and forced draft coolers or condensers require separate guidelines for capacity control during cold weather operation.

The sequence of control for a unit operating at low ambient conditions is much the same as a cooler or condenser operating under summer conditions provided that the ambient temperature is above freezing. When the ambient temperatures are below freezing, additional precautions must be taken to avoid the potential for damaging ice formation.

The most effective way to avoid ice formation in and on a closed circuit cooler or condenser during the winter is to run the unit **DRY**. In dry operation, the recirculation pump is turned off, the basin drained, and air passes over the coil. Instead of using evaporative cooling to cool the process fluid or condense the refrigerant, sensible heat transfer is utilized, so there is no recirculating water to freeze. If this method will be used on a forced draft unit, be sure to verify that the motor and drives have been properly sized to handle the reduction in static pressure experienced when the spray water is turned off.

It is very important to maintain close control of the cooler or condenser during winter operation. EVAPCO recommends that an absolute **MINIMUM** leaving water temperature of 42° F must be maintained for cooler applications. The higher the leaving temperature from the cooler or condenser, the lower the potential for ice formation.

Induced Draft Unit Capacity Control

The simplest method of capacity control is cycling the fan motor on and off in response to the leaving fluid temperature of the cooler or condenser. However, this method of control results in larger temperature differentials and longer periods of downtime. During extremely low ambient conditions, the moist air may condense and freeze on the fan drive system. Therefore, fans must be cycled during extremely low ambient conditions to avoid long periods of idle time when water is flowing over the coil. The number of start/stop cycles must be limited to no more than six (6) per hour.

A better method of control is the use of two-speed fan motors. This allows an additional step of capacity control. This additional step reduces the water temperature differential, and therefore, the amount of time the fans are off. In addition, two-speed motors provide savings in energy costs, since the cooler or condenser has the potential to operate on low speed for the

Cold Weather Operation (Continued)

reduced load requirements.

The best method of capacity control during cold weather operation is the use of a variable frequency drive (VFD). This allows the closest control of the leaving water temperature by allowing the fan(s) to run at the appropriate speed to closely match the building load. As the building load decreases, the VFD control system may operate for long periods of time at fan speeds below 50%. Operating a low leaving water temperature and low air velocity through the unit can cause ice to form. It is recommended that the minimum speed of the VFD be set at 50% of full speed to minimize the potential for ice to form in the unit.

Forced Draft Unit Capacity Control

The most common methods of capacity control are cycling the single speed fan motors, using two-speed motors or pony motors, and utilizing variable frequency drives to control the cooler or condenser fans. Although capacity control methods for forced draft units are similar to those used for induced draft units, there are slight variations.

The simplest method of capacity control for forced draft units is to cycle the fan(s) on and off. However, this method of control results in larger temperature differentials and periods of time with the fans off. When the fans are cycled off, the water falling through the unit can draw air flow into the fan section. During extremely low ambient conditions, this moist air may condense and freeze on the cold components of the drive system. When conditions change and cooling is needed, any amount of ice that has formed on the drive system can severely damage the fans and fan shafts. **Therefore, fans MUST be cycled during low ambient operation to avoid long periods of idle fan operation. Excessive cycling can damage the fan motors. Limit the number of cycles to a maximum of six (6) per hour.**

Two-speed or pony motors offer a better method of control. This additional step of capacity control will reduce water temperature differentials and the amount of time that the fans are off. This method of capacity control has proven effective for applications where load variations are excessive and cold weather conditions are moderate.

The use of a variable frequency drive provides the most flexible method of capacity control for forced draft units. The VFD control system allows the fans to run at nearly an infinite range of speeds to match the unit capacity to the system load. During periods of reduced load and low ambient temperatures, the fans must maintain enough speed to ensure positive air flow through the unit. This positive air flow in the unit will prevent moist air from migrating towards the cold fan drive components reducing the potential for condensation to form and freeze on them. The VFD control system should be implemented for applications that experience fluctuating loads and severe cold weather conditions.

Ice Management

When operating an evaporative cooling unit in extreme ambient conditions, the formation of ice is inevitable. The key to successful operation is to control or manage the amount of ice that builds up in the unit. If extreme icing occurs, it can lead to severe operational difficulties as well as potential damage to the unit. Following these guidelines will minimize the amount of ice that forms in the unit leading to better operation during the cold weather season.

Induced Draft Units

When operating an induced draft unit during the cold weather season, the control sequence must have a method to manage the formation of ice in the unit. The simplest method of managing the amount of ice buildup is by cycling the fan motors off while keeping the pump on. During these periods of idle fan operation, the warm water that is absorbing the building load flows through the coil to help melt the ice that has formed on the coil, basin, or louver areas.

NOTE: Using this method during periods of high winds can cause blow through, resulting in splash-out and ice formation. To help prevent blow through and splash-out, maintain a minimum 50% fan speed.

In more severe climates, the incorporation of a defrost cycle can be used to mitigate and/or eliminate any detrimental effects of ice in the unit. During the defrost cycle, the fans are reversed at **half speed** while the recirculating pump flows water through the unit's water distribution system. Operating the unit in reverse will melt any ice or frost that may have formed in the unit or on the air intake louvers. **The defrost cycle requires the use of two-speed motors with reverse cycle starters or reversible variable frequency drives.** All motors supplied by EVAPCO are capable of reverse operation.

The defrost cycle should be incorporated into the normal control scheme of the cooler or condenser system. The control system should allow for either a manual or automatic method of controlling frequency and length of time required to completely defrost the ice from the unit. The frequency and length of the defrost cycle is dependent on the control methods and ambient cold weather conditions. Some applications will build ice quicker than others which may require longer and more frequent defrost periods. **Frequent inspection of the unit will help "fine-tune" the length and frequency of the defrost cycle.**

Cold Weather Operation (Continued)

Forced Draft Units

Defrost cycles are **NOT** recommended for forced draft units, since allowing the leaving water temperature set point to rise causes the fans to be off for very long periods of time. This is not recommended for forced draft coolers or condensers because of the potential for freezing the fan drive components. Therefore, the defrost cycle is an inappropriate method of ice management for forced draft units. However, low speed fan operation or variable frequency drives maintain a positive pressure in the unit which helps prevent ice formation on the fan drive components.

For more information on cold weather operation, please download a copy of EVAPCO's Engineering Bulletin 23 at evapco.com.

Troubleshooting

PROBLEM	POSSIBLE CAUSE	REMEDY
Overamping Fan Motors	Reduction in air static pressure	<ol style="list-style-type: none"> 1. On a forced draft unit, verify that the pump is on and water is flowing over the coil. If the pump is off, and the unit was not sized for dry operation, the motor may overamp. 2. If the forced draft unit is ducted, verify that the design external static pressure (ESP) matches the actual ESP. 3. Verify the correct pump rotation direction. If the pump is rotating incorrectly, it will result in less water flow, and therefore less overall static pressure. 4. Check the basin water level against the recommended level. <p>NOTE: Air density directly affects amp reading. Low air density can cause the fans to spin faster, thus increasing the amp draw.</p>
	Electrical issue	<ol style="list-style-type: none"> 1. Check voltage across all three legs of the motor. 2. Verify that the motor is wired per the wiring diagram, and connections are tight.
	Fan rotation	Verify that the fan is rotating in the correct direction. If not, switch the leads so it runs correctly.
	Mechanical failure	Verify that the fan and motor turn freely by hand. If not, there may be damage to the internal motor components or bearings.
	Belt tension	Check for proper belt tension. Extreme belt tension can cause the motor to overamp.
Unusual Motor Noise	Motor running single-phase	Stop motor and attempt to start it. Motor will not start again if single phased. Check wiring, controls, and motor.
	Motor leads connected incorrectly	Check motor connections against wiring diagram on motor.
	Bad bearings	Check lubrication. Replace bad bearings.
	Electrical unbalance	Check voltage and current of all three lines. Correct if required.
	Air gap not uniform	Check and correct bracket fits or bearing.
	Rotor unbalance	Rebalance.
	Cooling fan hitting end bell guard	Reinstall or replace fan.
Incomplete Spray Pattern	Nozzles clogged	Remove nozzles and clean. Flush water distribution system.
	Pump running backwards	Visually verify pump rotor rotation by turning pump off and then on. Verify amp draw.
	Inadequate pump flow for remote sump	Confirm inlet pressure at header meets required values.
	Strainer clogged	Remove strainer and clean.
Fan Noise	Blade rubbing inside of fan cylinder (induced draft models)	Check fan, fan shaft for proper alignment. Adjust cylinder to provide blade tip clearance.

Troubleshooting (Continued)

PROBLEM	POSSIBLE CAUSE	REMEDY
Scaled Inlet Louvers	Improper water treatment, insufficient bleed rates or excessive cycling of the fan motors, or high concentrations of solids in water	Scale should not be removed using a power washer or wire brush because it could damage the louvers. Remove the louver assemblies and let them soak in the cold water basin of the unit. The water treatment chemicals in the unit will neutralize and dissolve the buildup of scale. NOTE: The time required for soaking the inlet louvers depends on the severity of the scale buildup. NOTE: This assumes chemicals are being used.
Overramping Pump Motors	Initial startup	If the unit has only run for a few hours, the pump may overramp until the pump wear ring has worn in. In this case, it would only be small percentages, not 15 or 20%. Normally, after a few hours, the pump amp readings will reduce and level off.
	Mechanical failure	Verify that the pump can turn freely by hand. If not, pump most likely needs to be replaced.
	Electrical issue	Verify that the pump has been wired properly. Verify that the voltage supplying the pump is correct.
	Misconception of head increase or decrease	NOTE: Increase or decrease in pump flow as a result of clogged or blown out nozzles or headers should NOT cause the pump to over amp.
Makeup Valve Will Not Shut Off	Makeup water pressure too high	Mechanical makeup valve water pressure must be between 20 and 50psi. If pressure is too high, the valve will not close. A pressure reducing valve can be added to lower the pressure. For the 3- and 5-probe EWLC package, the electrical actuator has a 5 to 125 psi water pressure requirement.
	Debris in solenoid	Clean out solenoid of any debris.
	Frozen float ball	Inspect float and valve for damage and replace as needed.
	Float ball is full of water	Check ball for leaks and replace.
Water Constantly Blowing Out Overflow Connection	This can happen on forced draft units due to the positive pressure in the casing section. Overflow connection has not been piped at all or properly	Pipe the overflow with a P-trap to an appropriate drain.
	Incorrect water level	Verify actual operating level versus O&M recommended levels.
Water Intermittently Blowing Out Overflow Connection	This is normal	This is normal. The bleed line for the unit is piped to the overflow connection.
Cold Water Basin Overflowing	Problem with makeup line	Refer to "Makeup Valve" or "Electronic Water Level (EWLC)" section.
	If multi-cell unit, there may be an elevation problem	Make sure that multi-cell units are installed level to one another. If they are not, it can cause overflowing in one cell.
Low Pan Water Level	Electronic Water Level Control	See "Electronic Water Level (EWLC)" section.
	Float ball not set correctly	Adjust float ball up or down to obtain proper water level. NOTE: The float ball is set to the operating level at the factory.

Troubleshooting (Continued)

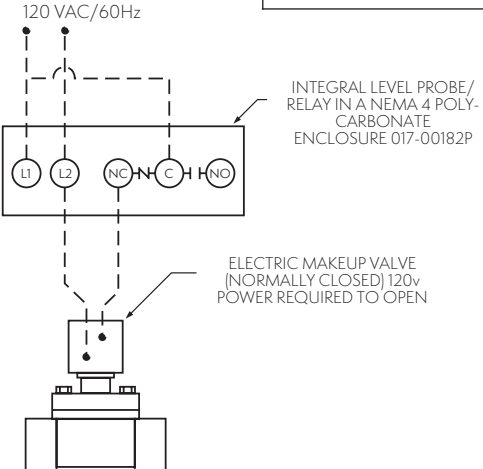
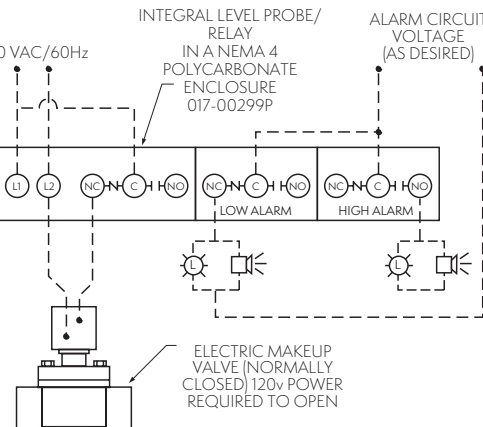
PROBLEM	POSSIBLE CAUSE	REMEDY
Rusting Stainless Steel	Foreign material on surface of stainless steel	Rust spots that show up on the surface of the unit are typically not signs of the base stainless steel material corroding. Often, they are foreign material, such as welding slag, that has collected on the surface of the unit. The rust spots will be located around where there has been welding. These areas may include the coil connections, the cold water basin near the support steel, and around field erected platforms and catwalks. The rust spots can be removed with a good cleaning. EVAPCO recommends using either Naval Jelly or a good stainless steel cleaner, such as Mother's® Wax in conjunction with a Scotch-Brite™ pad. Maintenance of the unit's surface should be done on a regular basis.
Cracking Fluid Cooler Insulation	Cracking paint	Most of the time, it is the paint that is cracking and not the insulation. If the paint is degrading, it should be touched up to maintain the finish on the insulation. It is recommended that maintaining the finish of the insulation paint be a part of the standard maintenance program. If the insulation is cracking, see your local EVAPCO representative for further guidance.
Electric Water Level Control Not Working  <p>120 VAC/60Hz</p> <p>INTEGRAL LEVEL PROBE/RELAY IN A NEMA 4 POLY-CARBONATE ENCLOSURE 017-00182P</p> <p>ELECTRIC MAKEUP VALVE (NORMALLY CLOSED) 120V POWER REQUIRED TO OPEN</p>	The valve won't open or close	<ol style="list-style-type: none"> 1. Verify that water pressure is above 5psi and below 100psi. 2. Verify wiring with wiring diagram. Check supply voltage. 3. Verify that there is not a blockage in the Y-strainer. 4. Confirm the probes are not dirty. 5. Check red LED on circuit board. If it is on, the valve should be closed. <p>For a 3-Probe Assembly:</p> <p>Simulate "Low Water Condition" — LED OFF After cleaning the probes, lift probe assembly out of the stand pipe. This will simulate a "low water condition". Check the contacts for proper position.</p> <ul style="list-style-type: none"> - The contact between "C" and "NC" should now be closed and water makeup valve should be energized (valve open). <p>Simulate "High Water Condition" — LED ON</p> <ul style="list-style-type: none"> - Connect a jumper wire between the longest probe and the shortest probe. The contact between "C" and "NC" should now be open and the water makeup valve should be de-energized (valve closed).
Electric Water Level Control Not Working  <p>120 VAC/60Hz</p> <p>INTEGRAL LEVEL PROBE/RELAY IN A NEMA 4 POLY-CARBONATE ENCLOSURE 017-00299P</p> <p>ALARM CIRCUIT VOLTAGE (AS DESIRED)</p> <p>ELECTRIC MAKEUP VALVE (NORMALLY CLOSED) 120V POWER REQUIRED TO OPEN</p>		<p>For a 5-Probe Assembly:</p> <p>Simulate "Low Water Condition" After cleaning the probes, lift probe assembly out of the stand pipe. This will simulate a "low water condition". Check the contacts for proper position.</p> <ul style="list-style-type: none"> - Differential Contacts: C to NC - closed - Water makeup valve energized - LED = OFF - High Alarm Contacts: C to NO - open - High alarm circuit de-energized - LED = OFF - Low Alarm Contacts: C to NC - closed - Low alarm circuit energized - LED = OFF <p>Simulate "High Water Condition" Connect a jumper wire between the longest probe (ground) and all other probes (high limit, high alarm, and low alarm). Check the contacts for proper position.</p> <ul style="list-style-type: none"> - Differential Contacts: C to NC - open - Water makeup valve de-energized - LED = ON - High Alarm Contacts: C to NO - closed - High alarm circuit energized - LED = ON - Low Alarm Contacts: C to NC - open - Low alarm circuit de-energized - LED = ON

Replacement Parts

EVAPCO has replacement parts available for immediate shipment. Most orders ship within 24 hours from time of order!

The following pages contain **exploded view drawings** of all current EVAPCO closed circuit coolers and condensers, organized by product line and size. Please use these drawings to help identify the major parts of your unit. If you are unable to identify the part you need using these figures, please visit www.evapco.com for additional resources and/or contact your local EVAPCO sales representative.

The local EVAPCO representative or Mr. GoodTower® Service Center can provide unit inspection(s) to help ensure you have the replacement parts you need to keep your equipment operating at peak performance regardless of the original manufacturer!

To order replacement parts, please contact your local EVAPCO sales representative or Mr. GoodTower® Service Center. The local EVAPCO representative's contact information is located on the unit's nameplate or can be found by visiting www.evapco.com.

Parts Identification Drawings

To properly use the following drawings, refer to the various vantage points and associated markers (i.e. motor side, pan & plenum section, etc.) to help you identify the major parts within your cooling tower. Be sure to refer to the option that matches your specific unit and size as the configuration(s) may change based on these details.

These figures are **not** intended to illustrate all parts within the unit, but rather provide an overview that allows you to identify larger components. If you need additional assistance with your parts-related questions or concerns, please contact your local EVAPCO sales representative.

ATC-E / ATWB /eco-ATWB 4'x6' Wide Units

FAN & COIL CASING SECTION

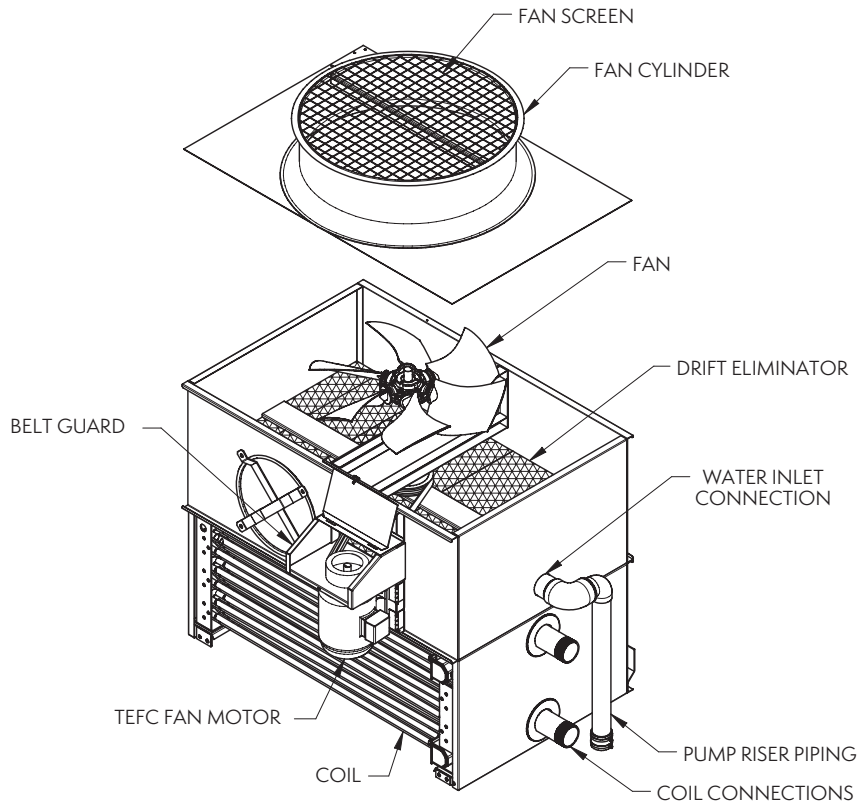

PAN SECTION

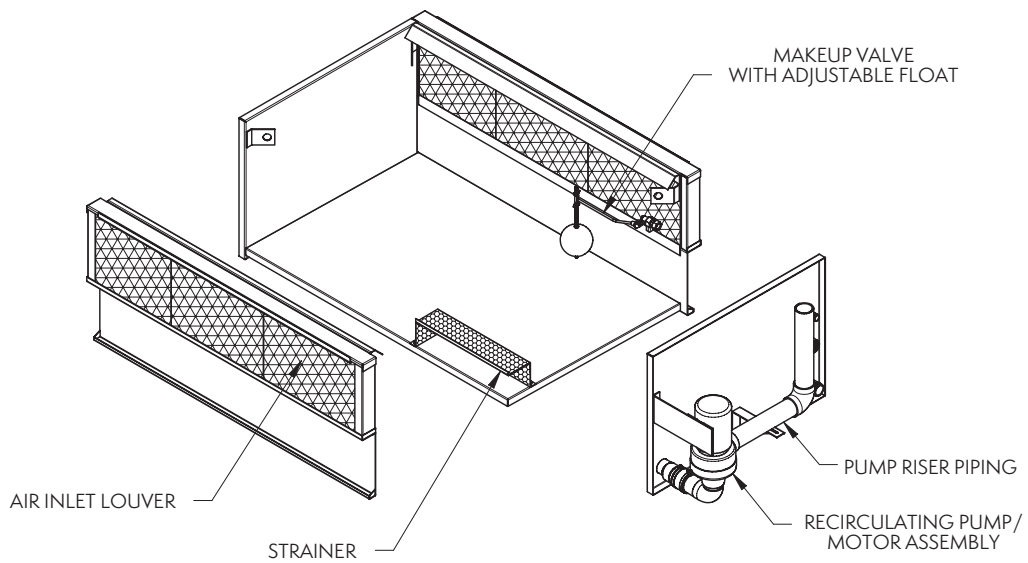

ATC-E / ATWB / eco-ATWB 4'x9' & 4'x12' Wide Units

FAN & COIL CASING SECTION

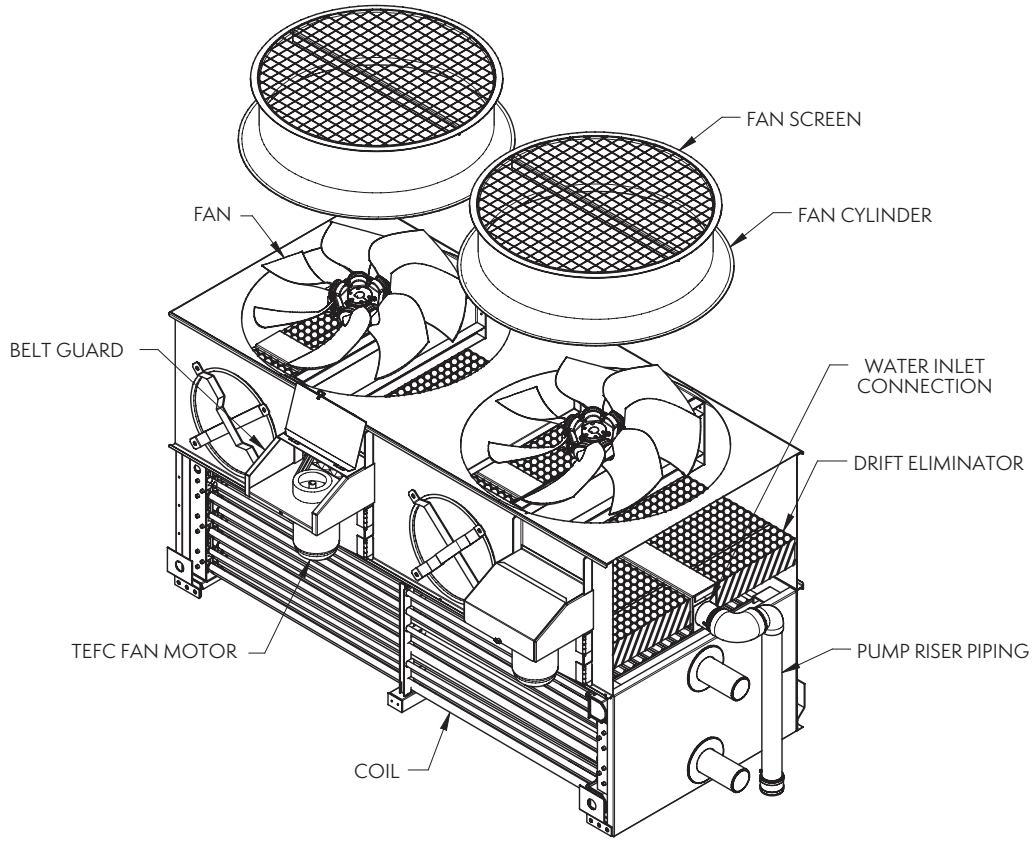

PAN SECTION

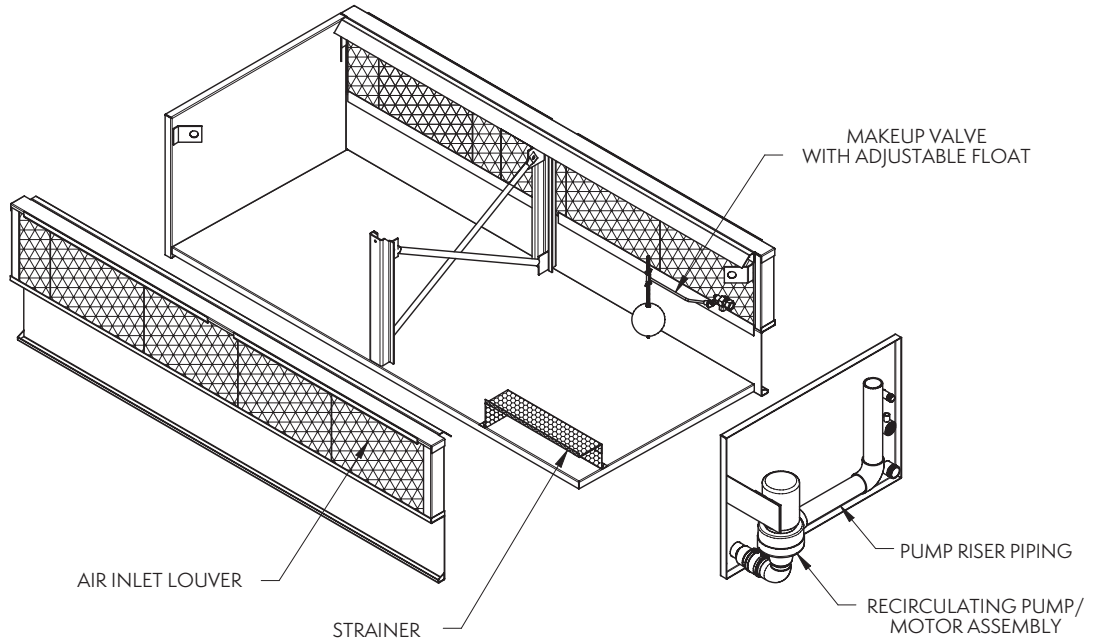

ATC-E/ATWB/eco-ATC-A/eco-ATWB 7' Wide Units

FAN & COIL CASING SECTION

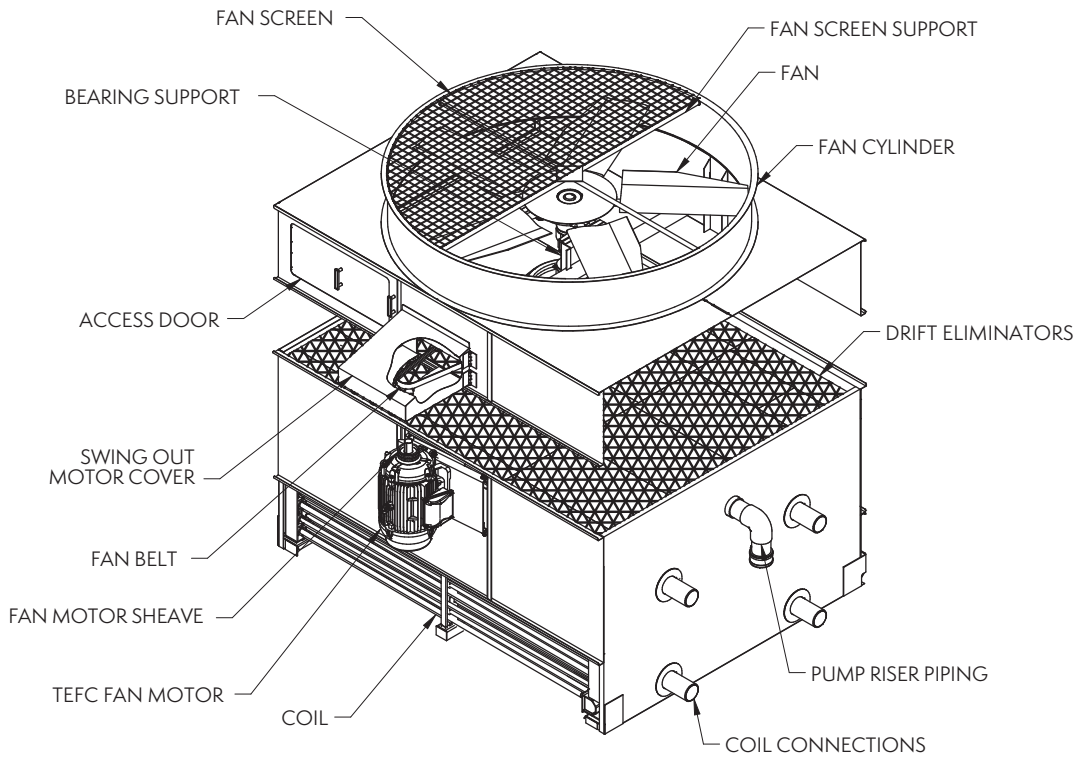

PAN SECTION

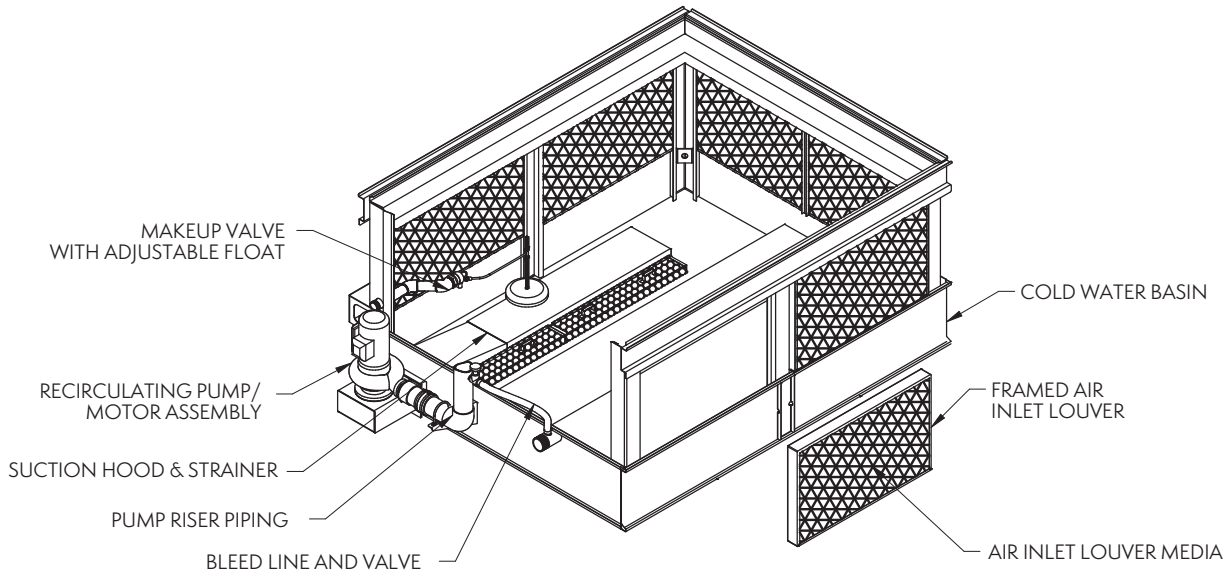

ATC-E / ATWB / eco-ATC -A/ eco-ATWB 8' & 8.5' Wide Units

FAN & COIL CASING SECTION

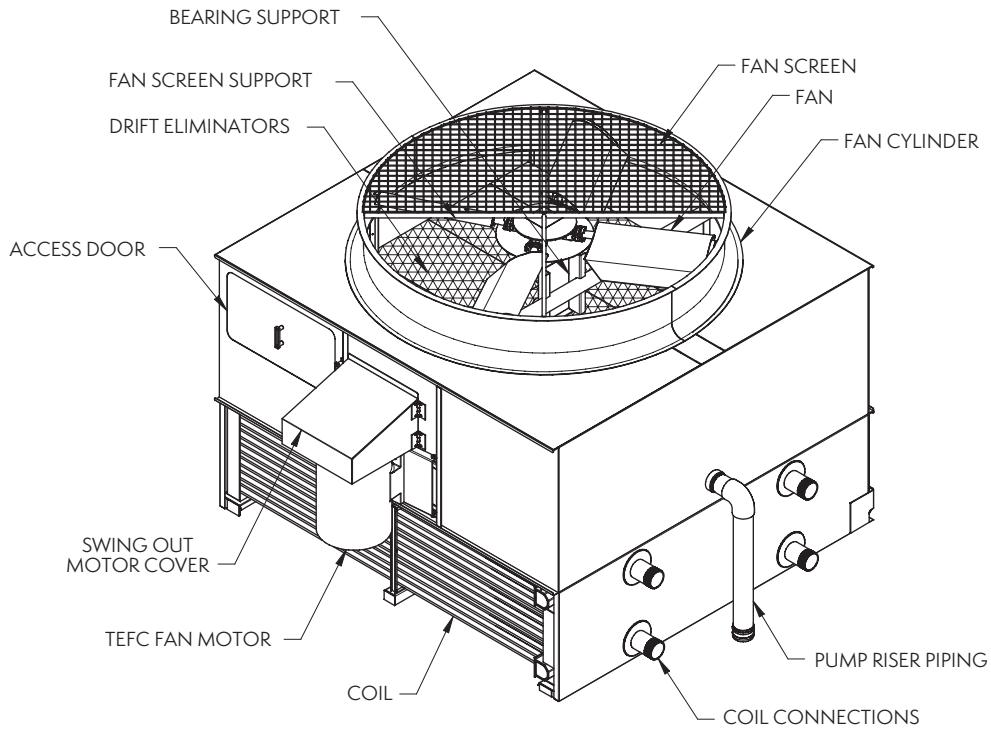

PAN SECTION

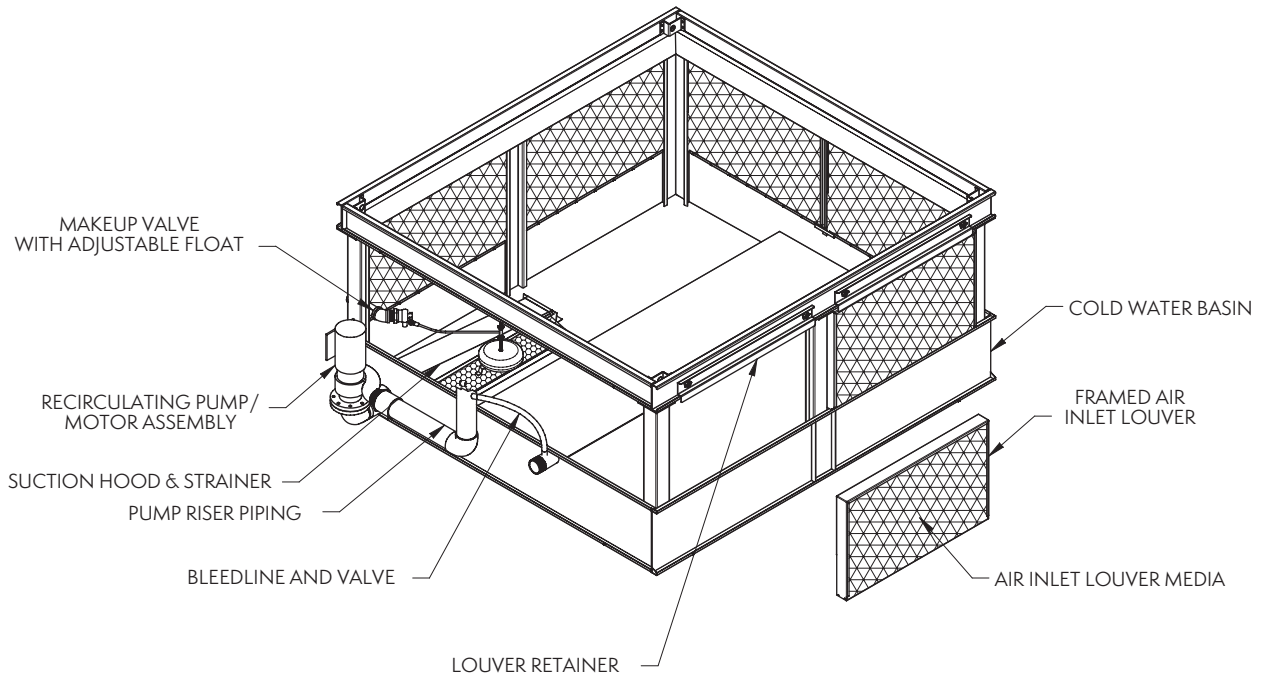

eco-ATC-H and eco-ATWB-H 8.5' Wide Units

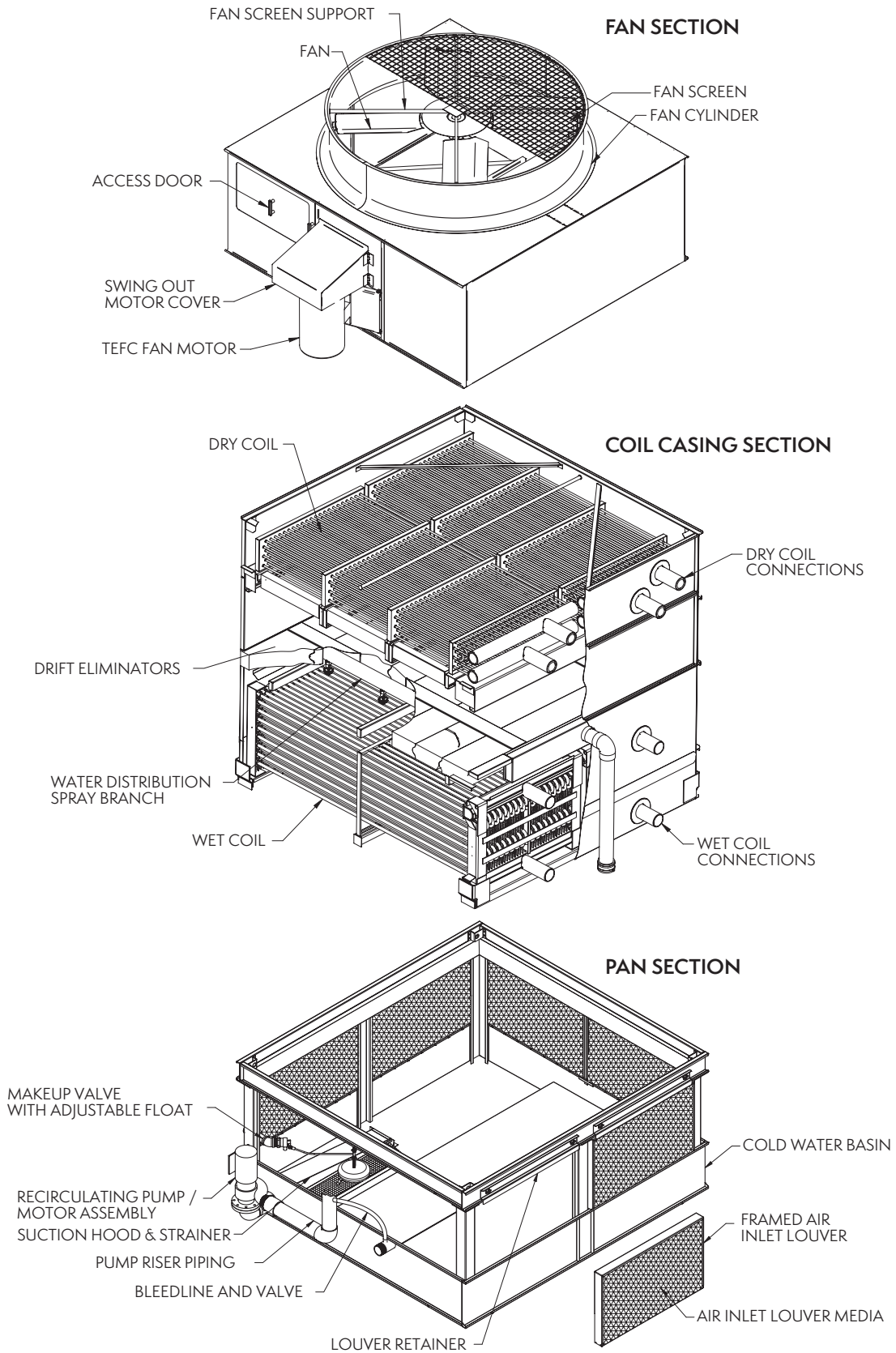

ATC-E / ATWB / eco-ATC -A/ eco-ATWB 10' & 12' Wide Units

FAN & COIL CASING SECTION

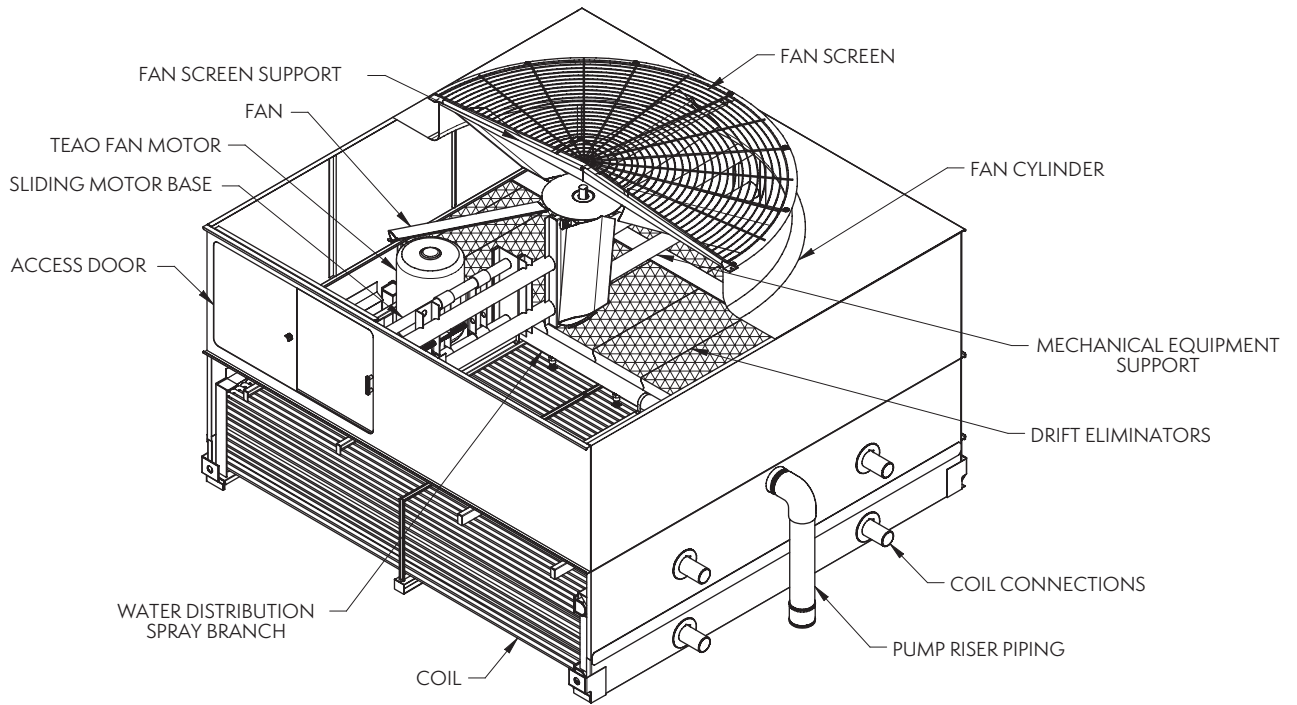

PAN SECTION

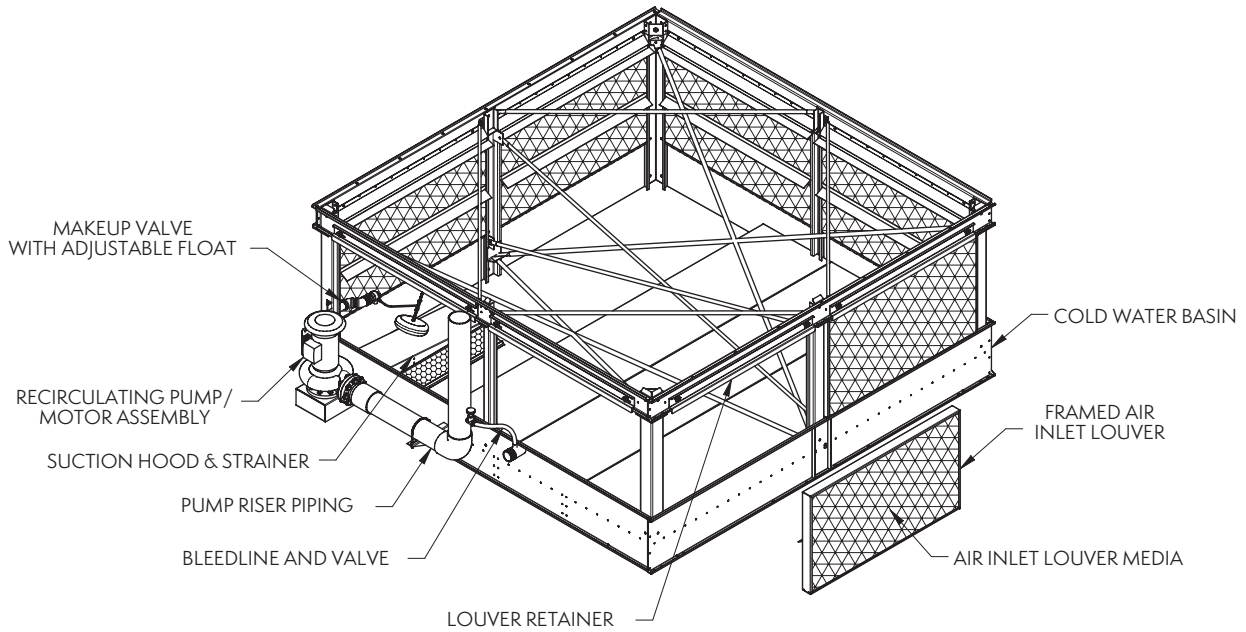

eco-ATC-H / eco-ATWB-H 10' and 12' Wide Units

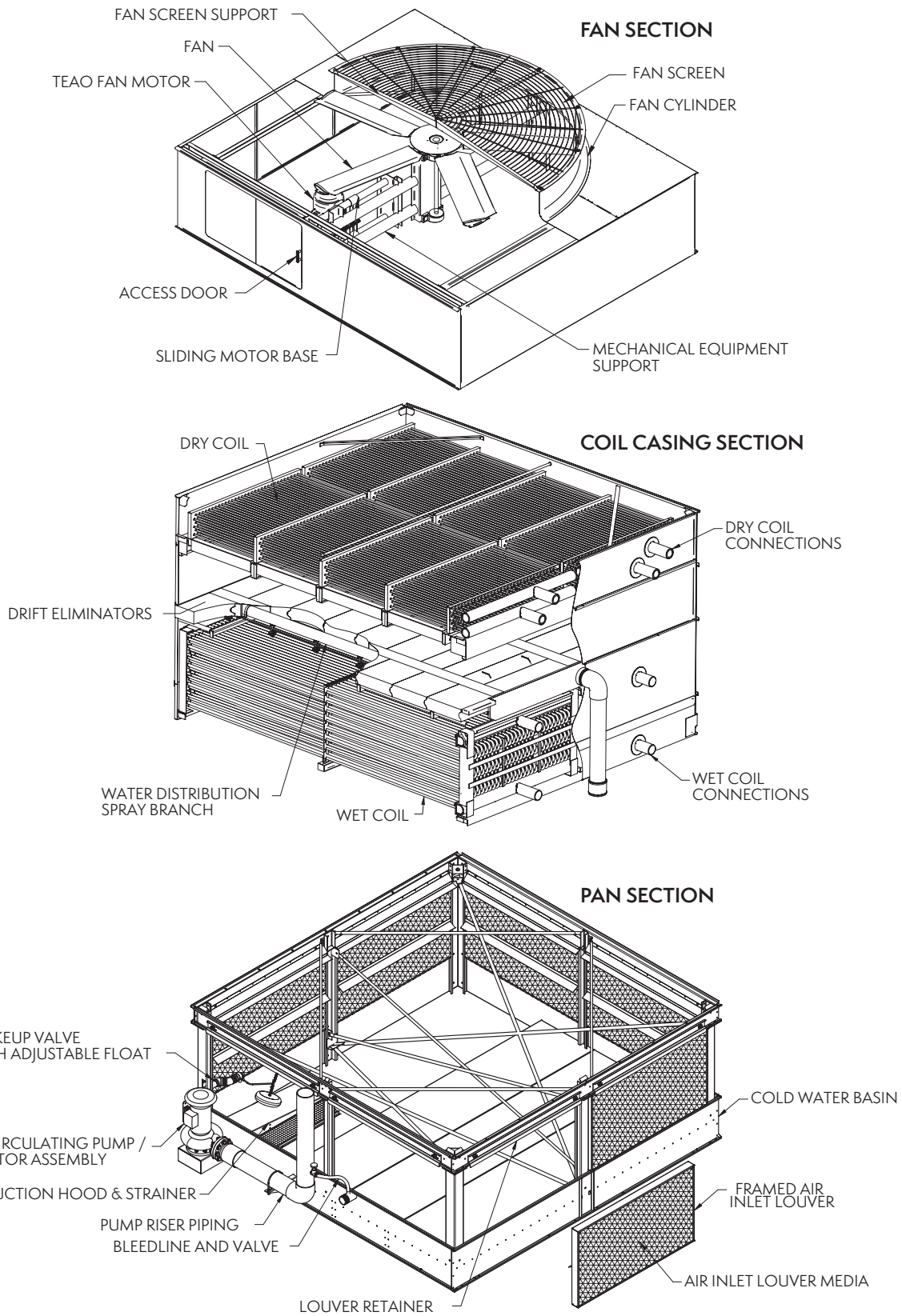

ESW4 8.5' Wide Units

FAN & FILL CASING SECTION

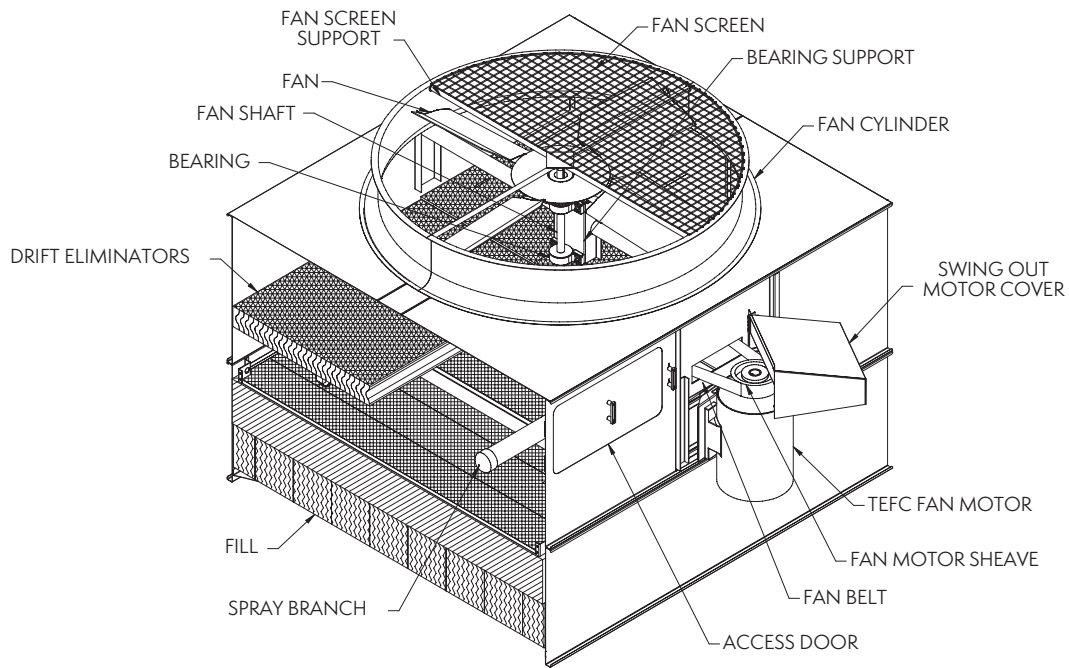

PAN SECTION

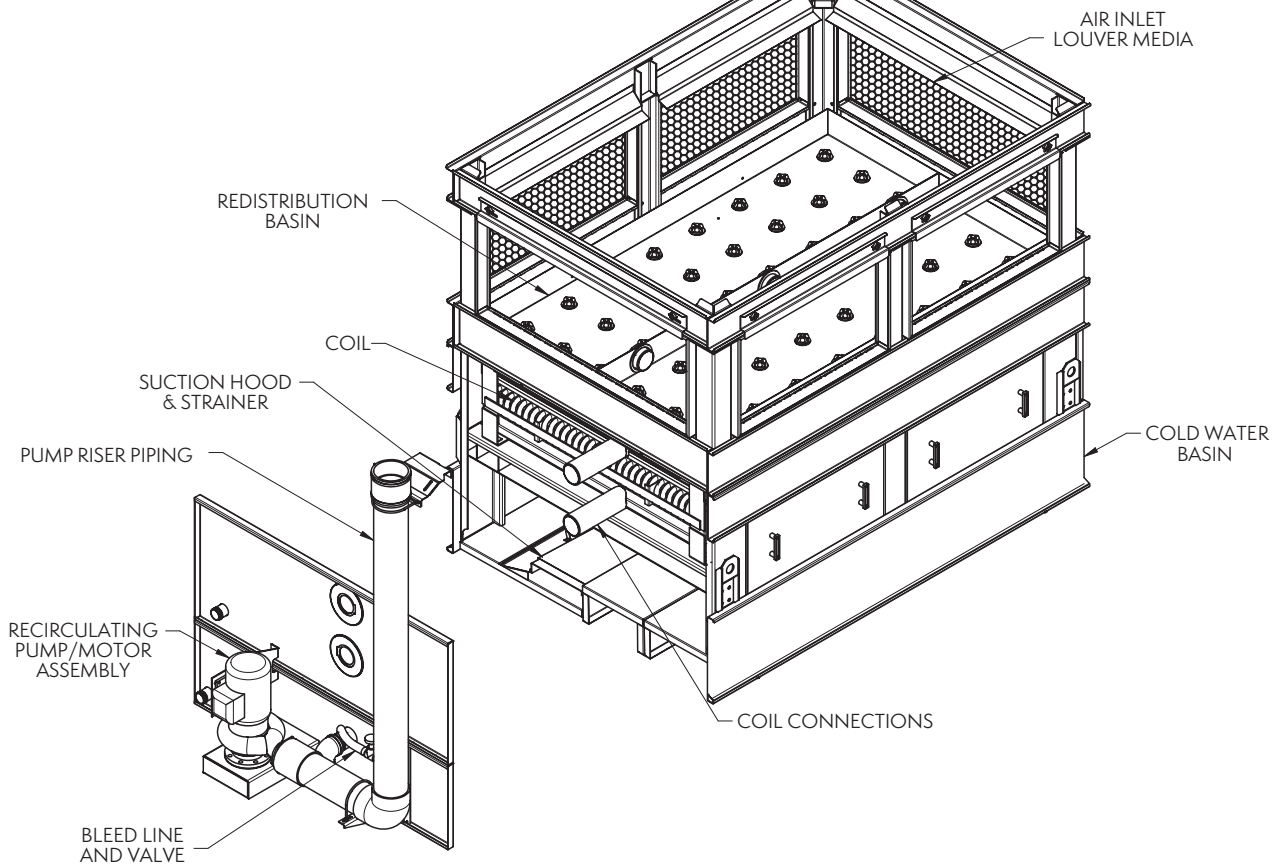

ESW4 12' Wide Units

FAN & FILL CASING SECTION

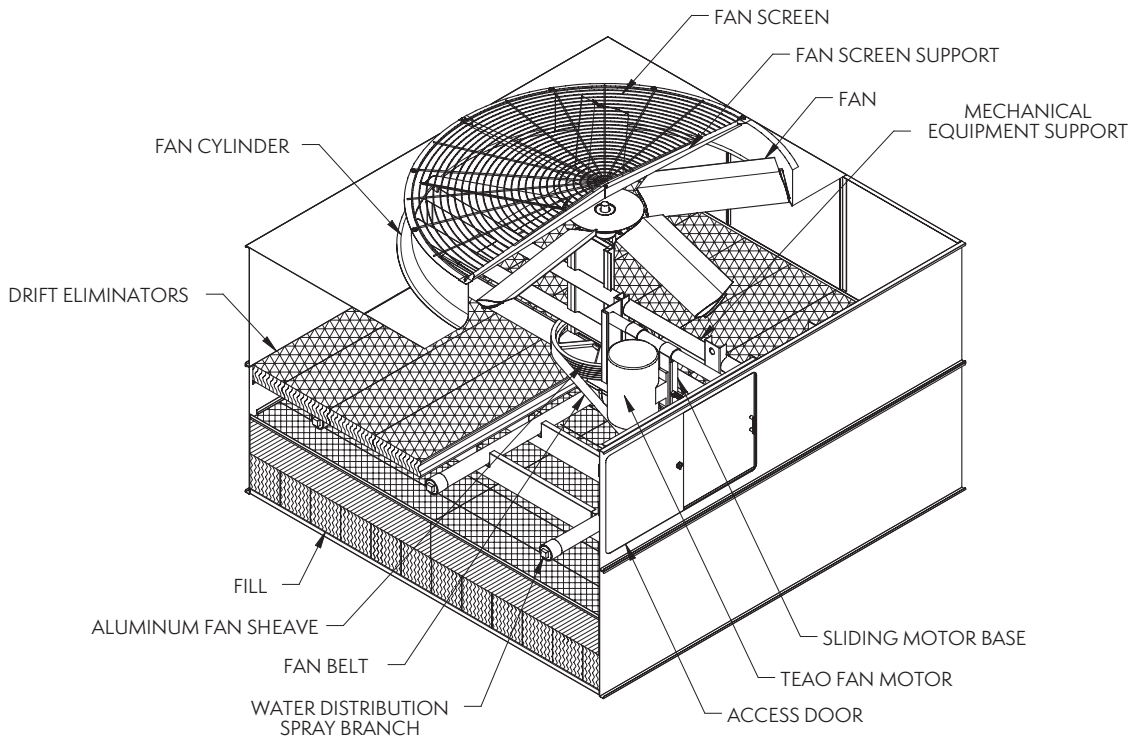

PAN SECTION

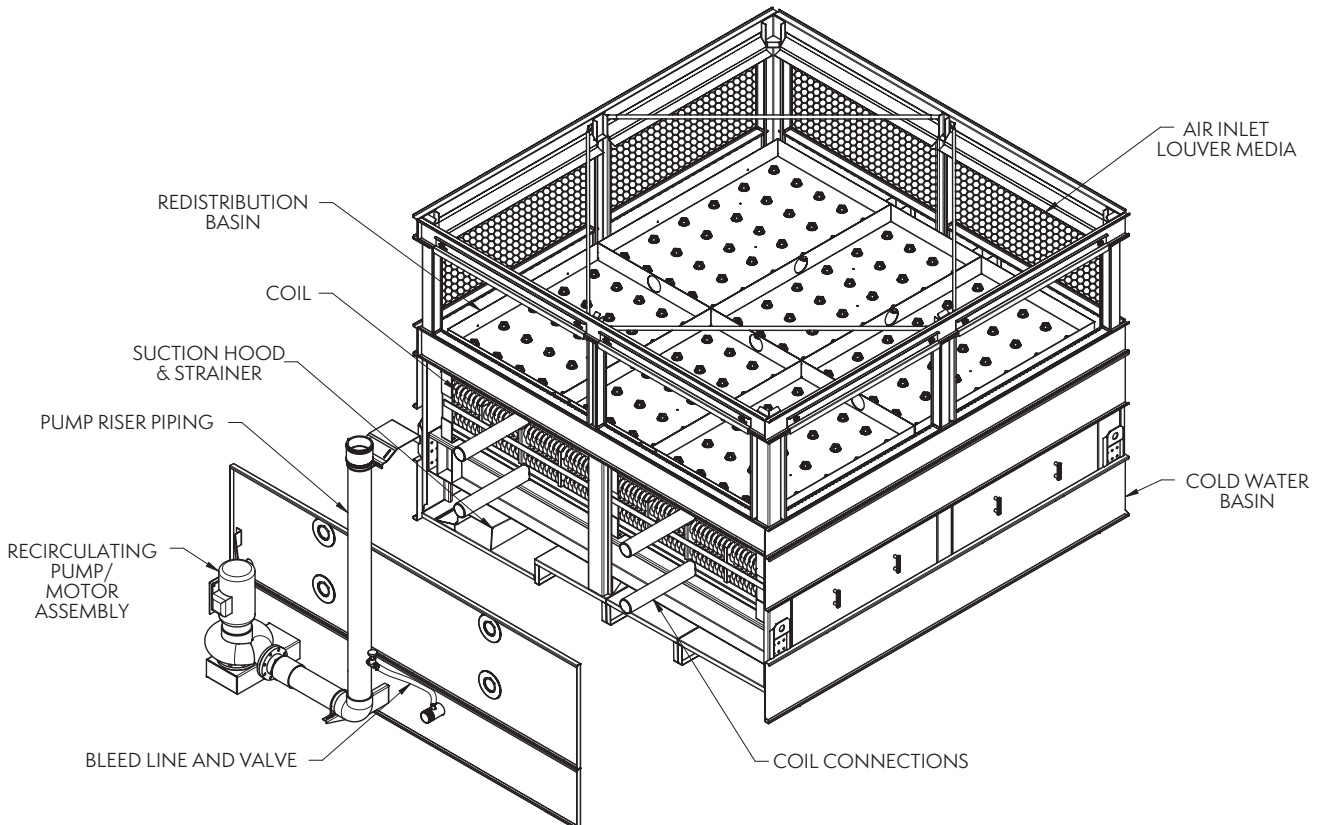

ESW4 14' Wide Units

FAN & FILL CASING SECTION

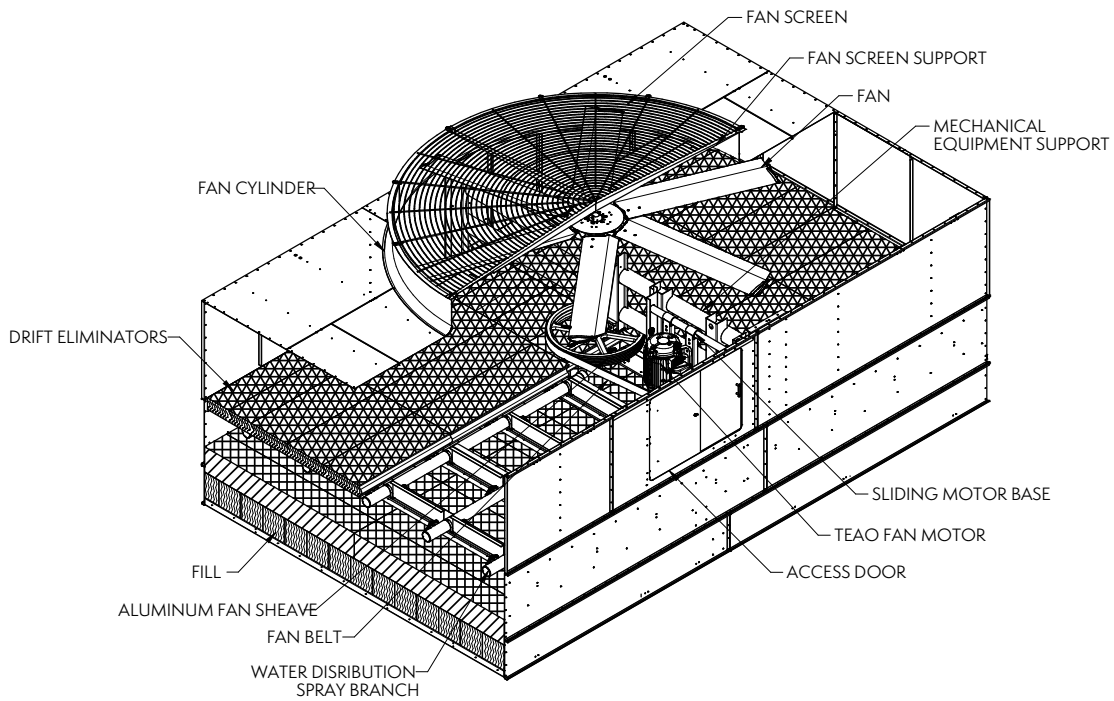

PAN SECTION

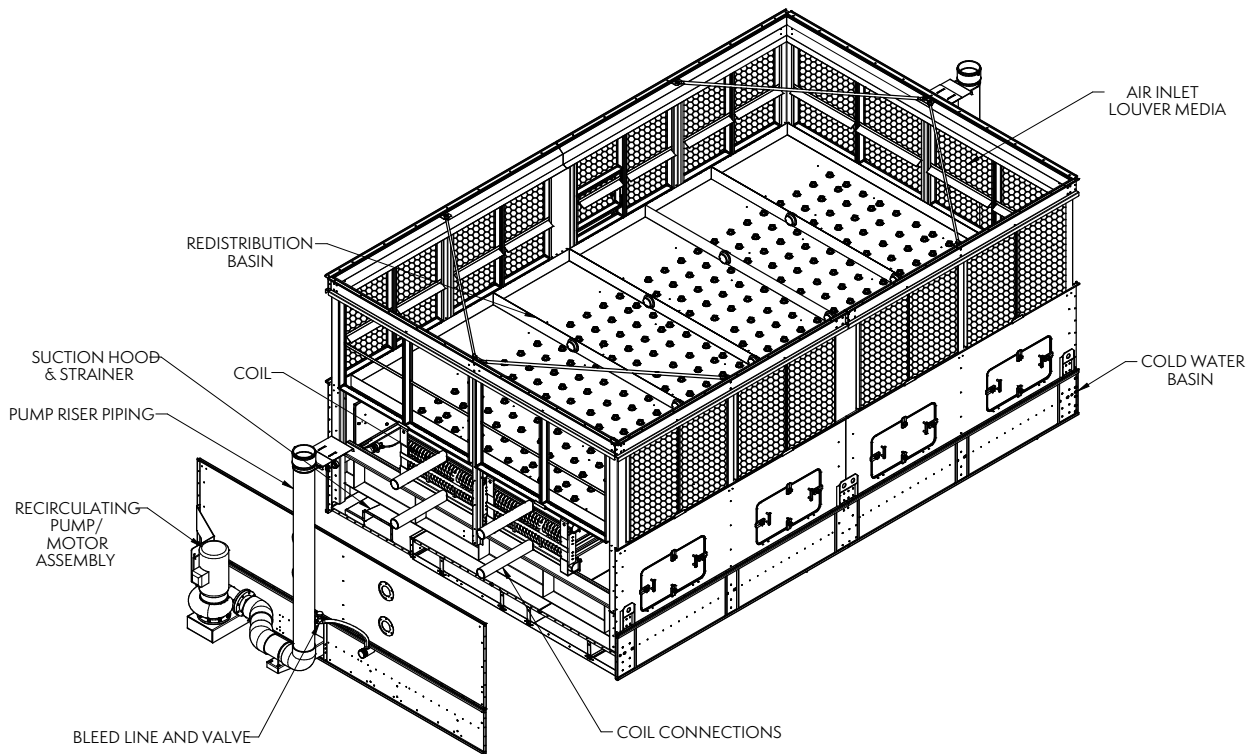

LSC-E/LSWE/eco-LSWE 4' Wide Units

COIL CASING SECTION

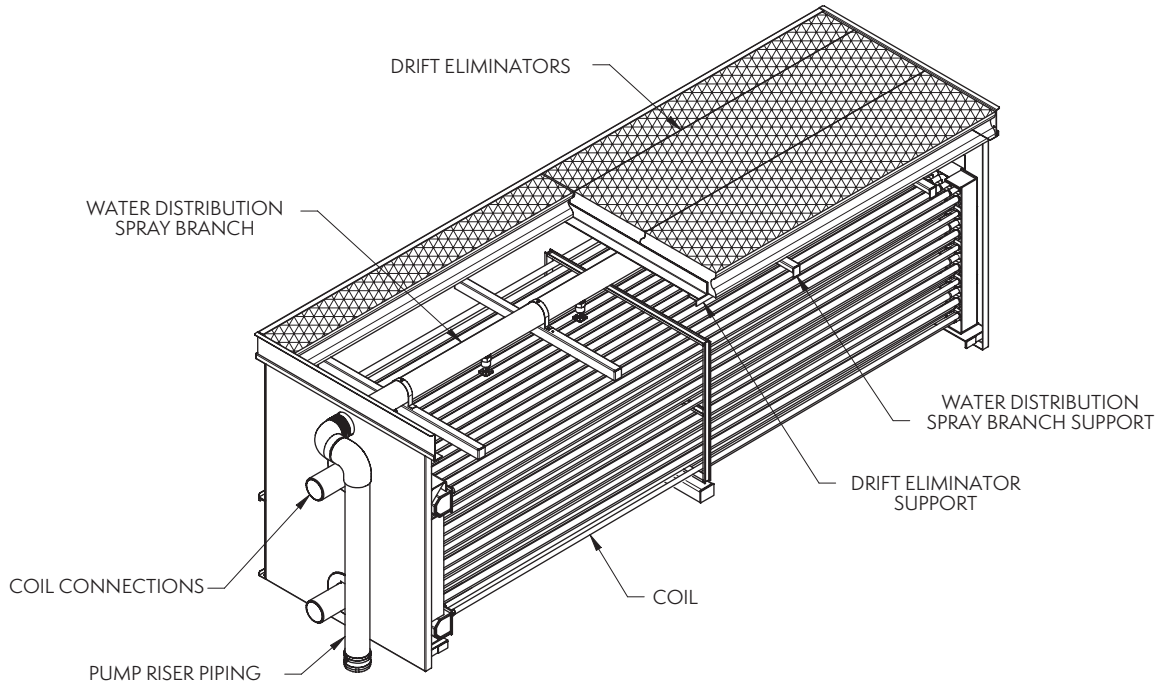

PAN SECTION

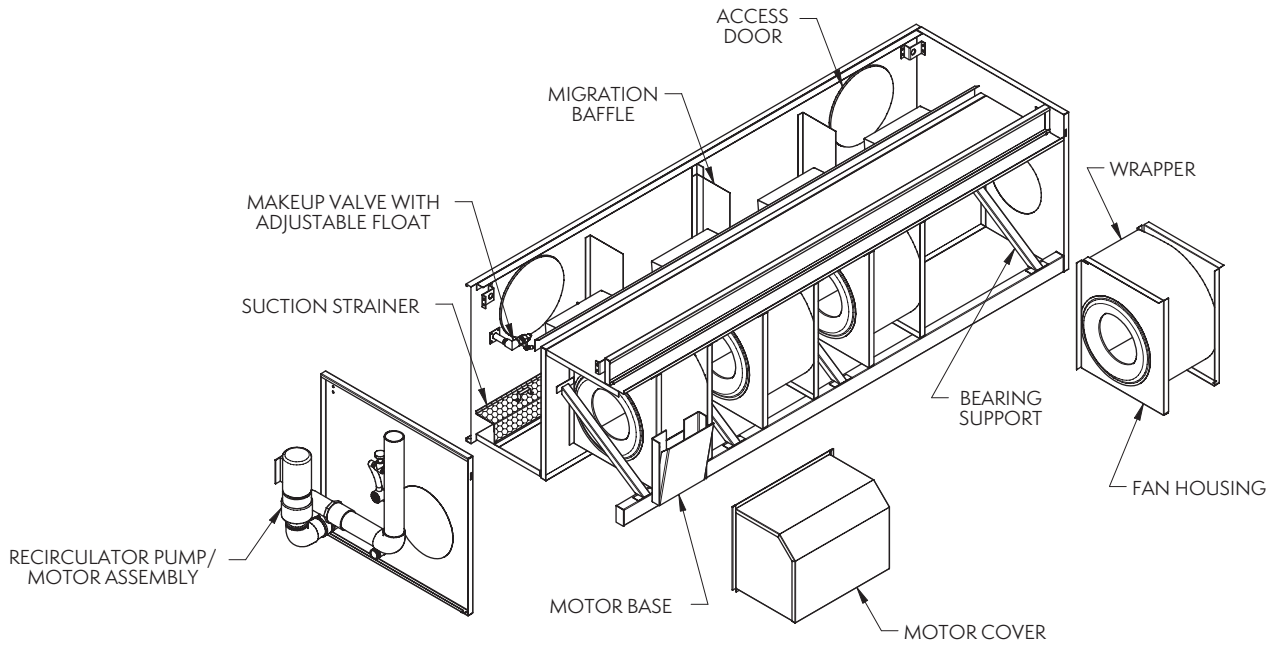

LSC-E/LSWE/eco-LSWE 5' Wide Units

COIL CASING SECTION

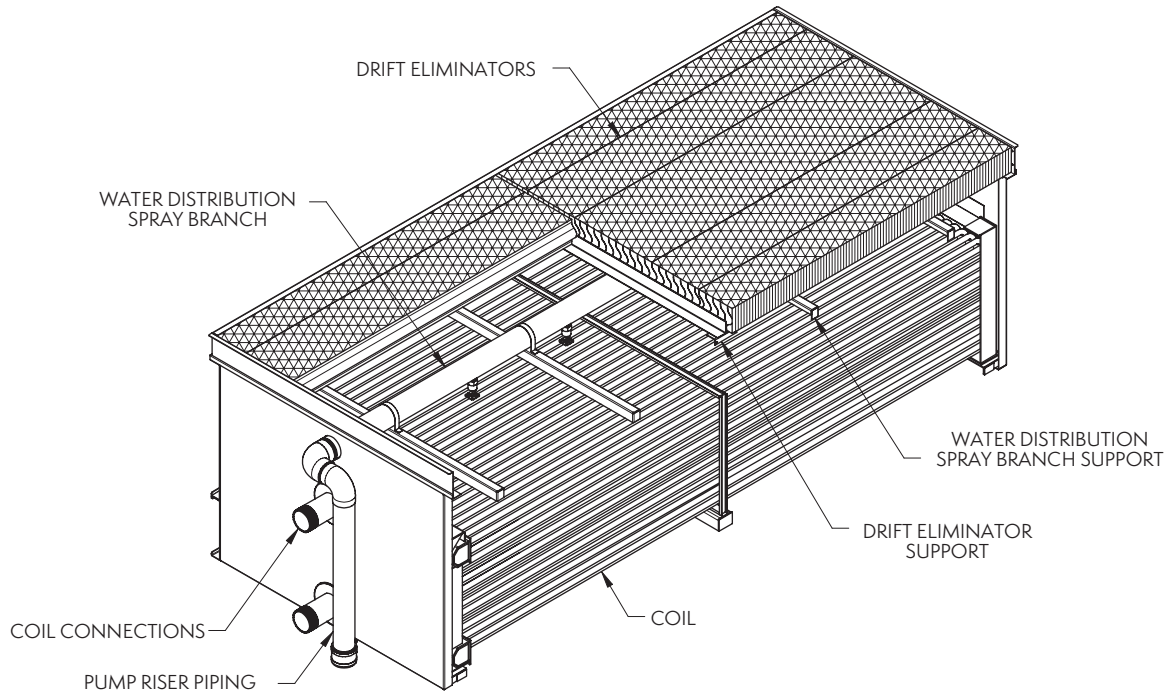

PAN SECTION

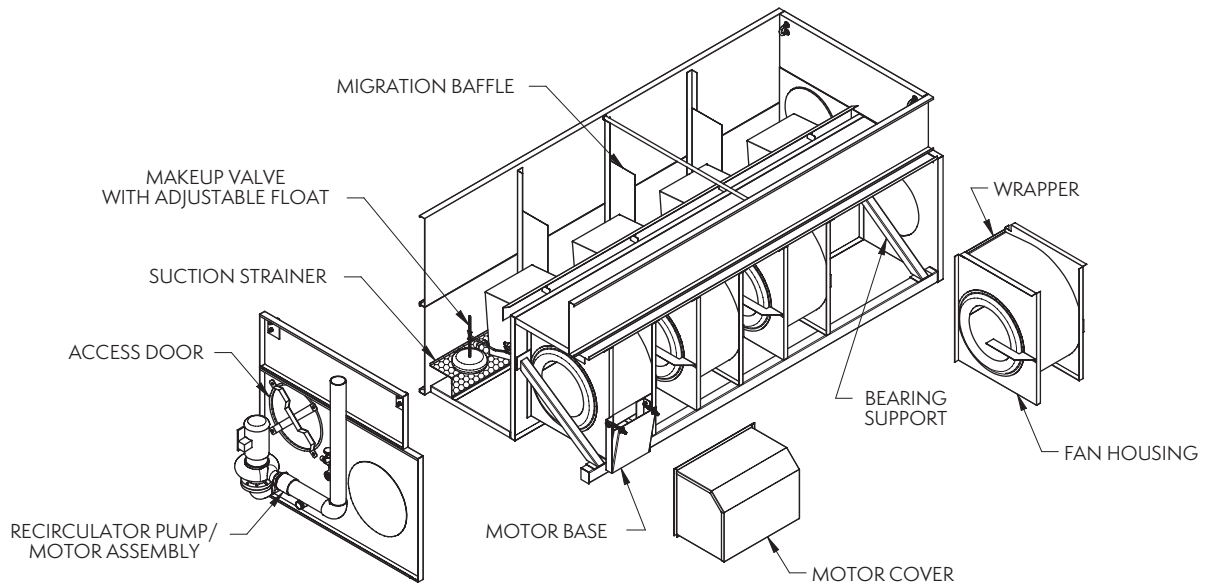

LSC-E/LSWE/eco-LSWE 8' Wide Units

COIL CASING SECTION

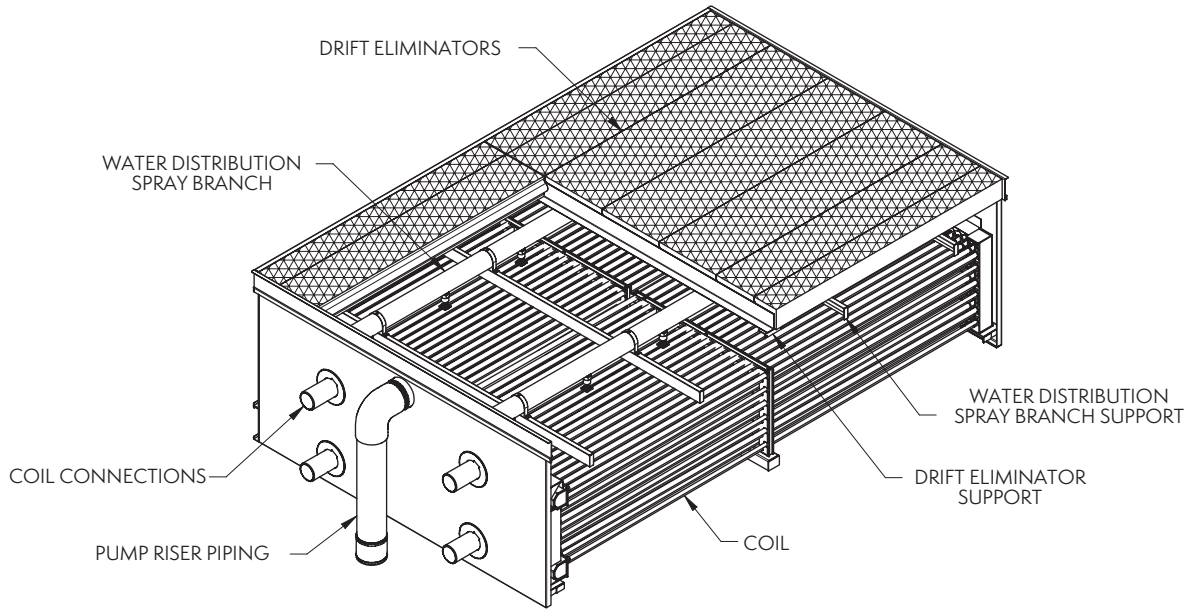

PAN SECTION

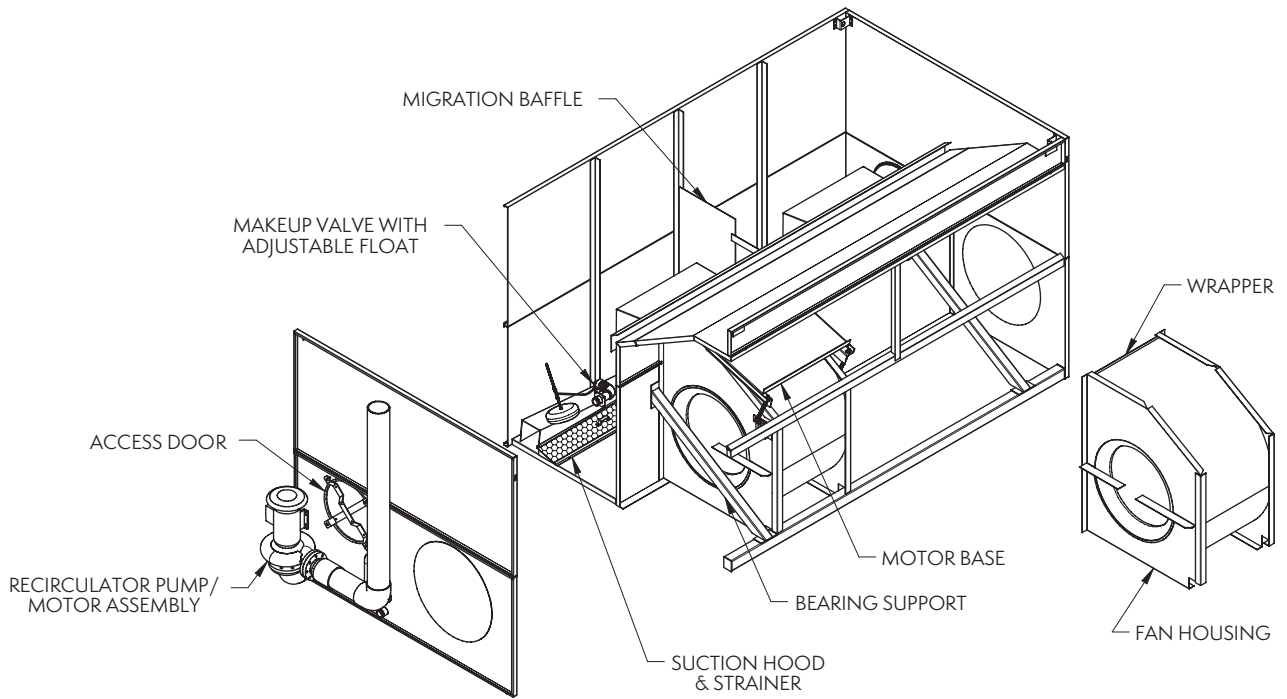

LSC-E/LSWE/eco-LSWE 10' Wide Units

COIL CASING SECTION

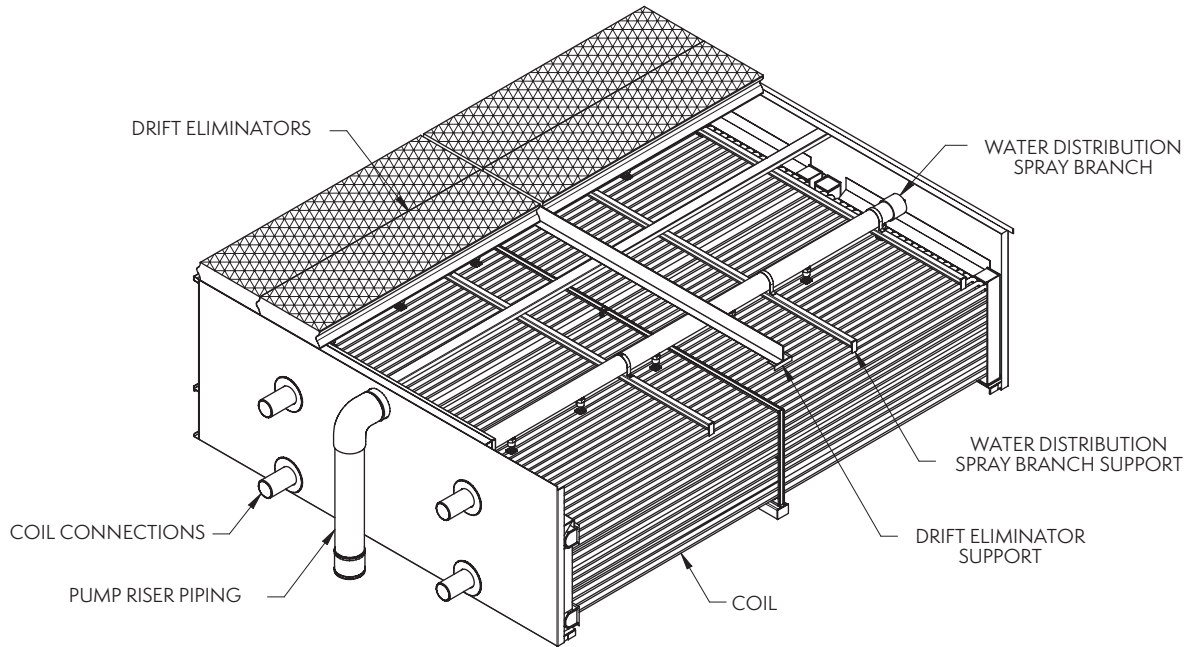

PAN SECTION

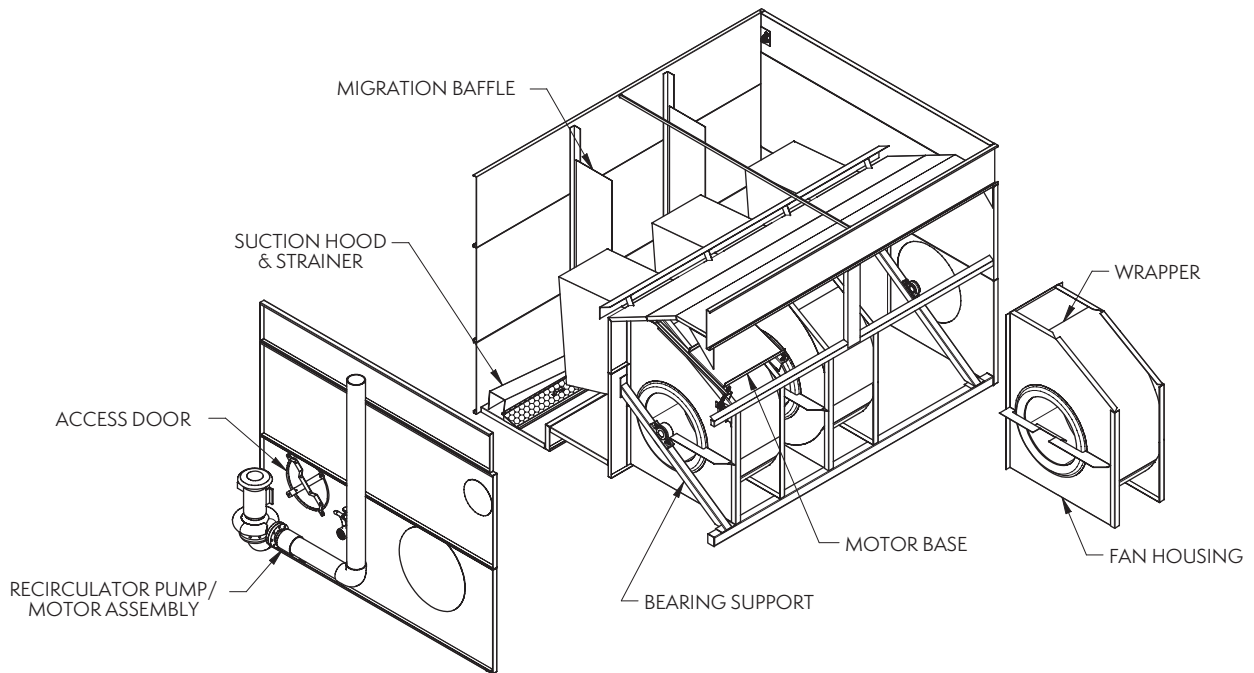

LRC/LRWB/eco-LRWB 3' Wide Units

COIL CASING SECTION

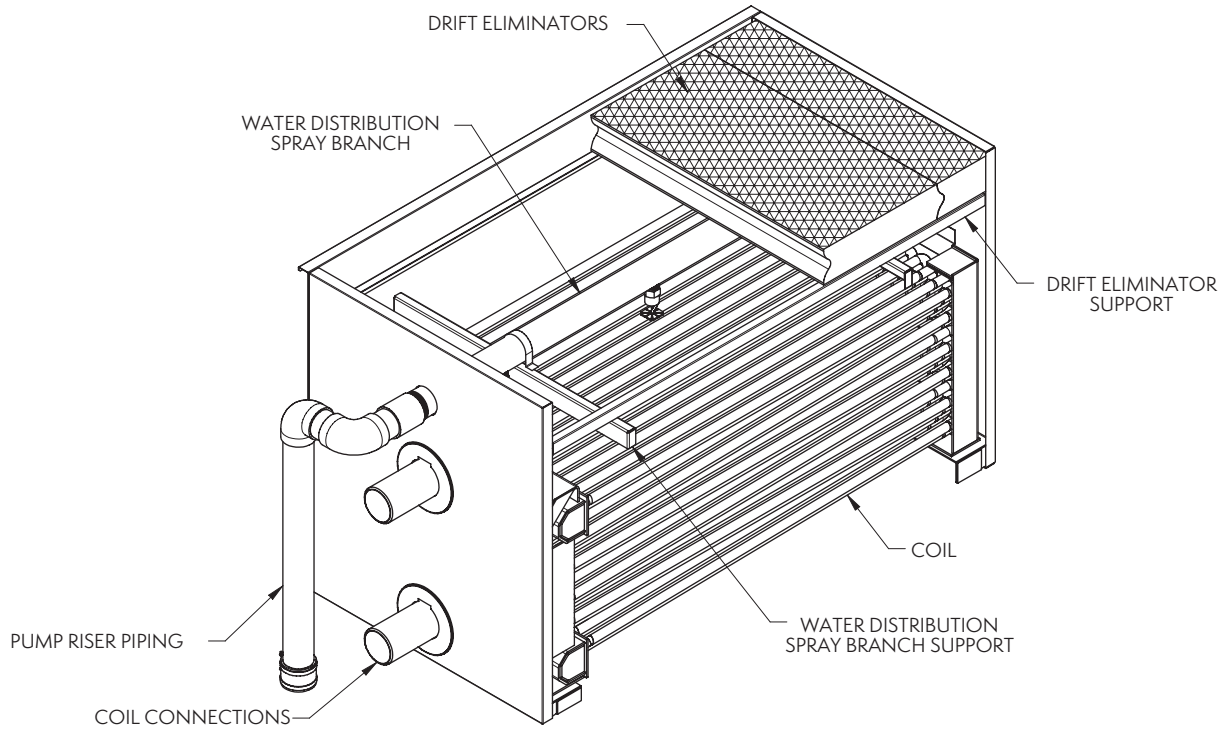

PAN SECTION

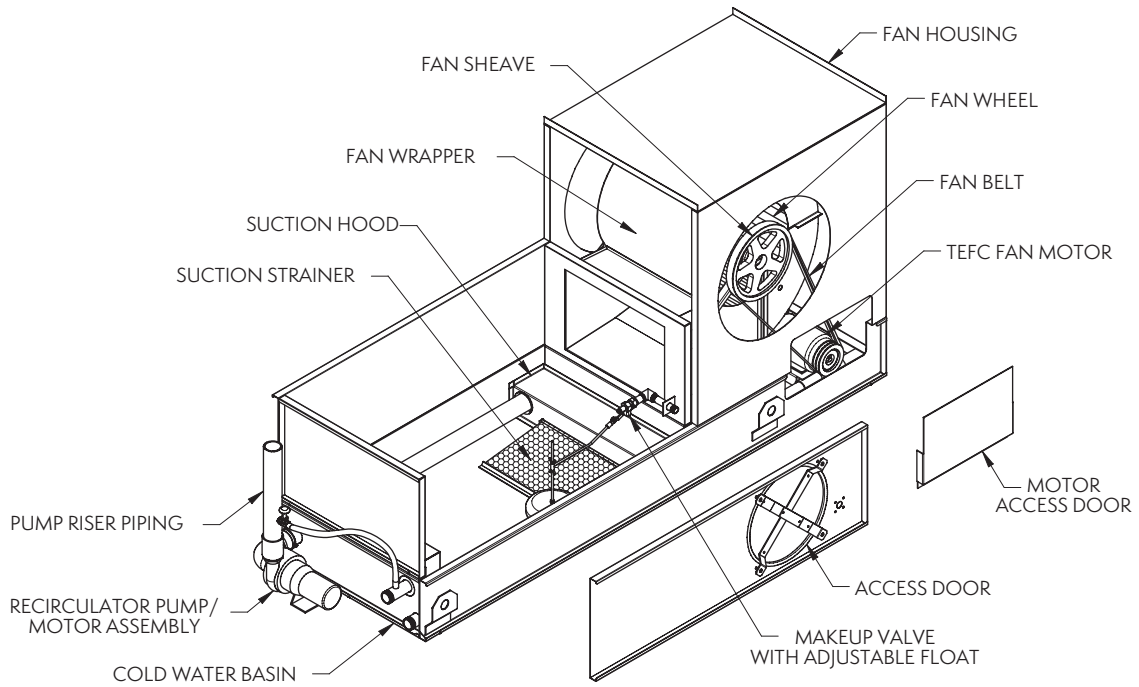

LRC/LRWB/eco-LRWB 5' Wide Units

COIL CASING SECTION

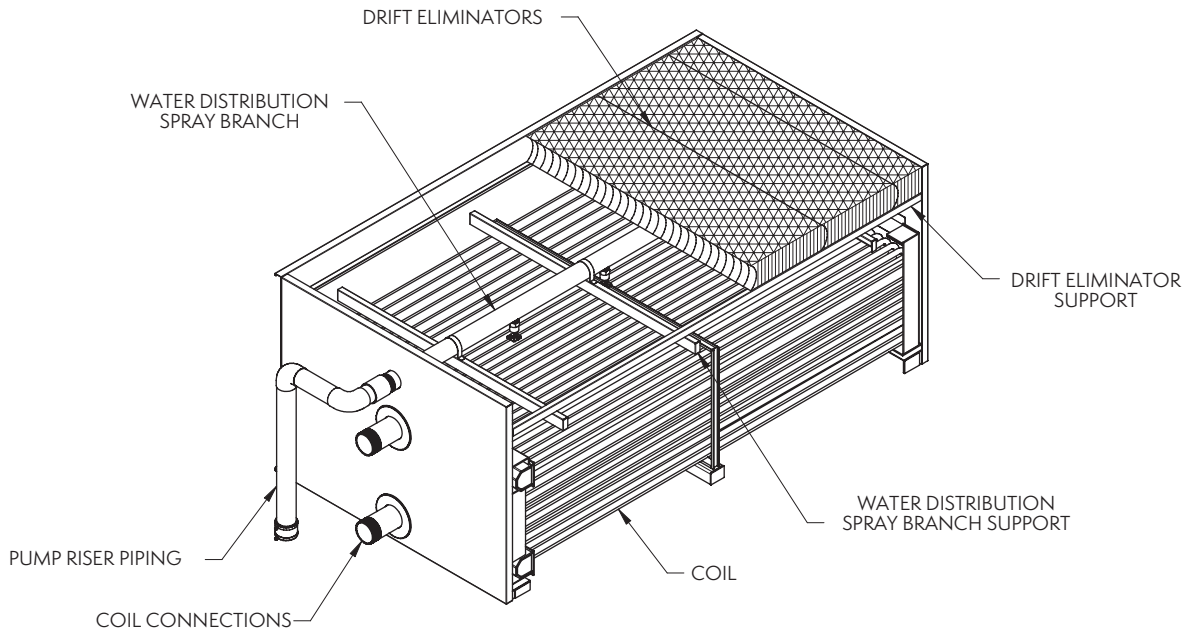

PAN SECTION

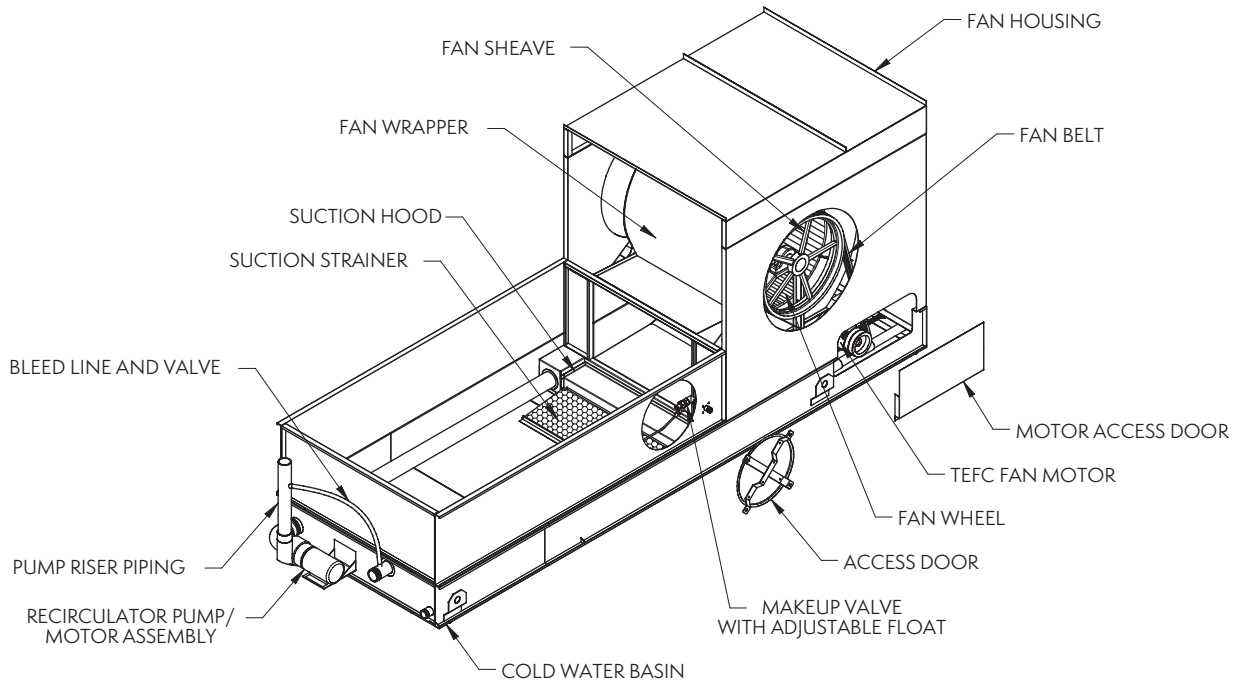

LRC/LRWB/eco-LRWB 8' Wide Units

COIL CASING SECTION

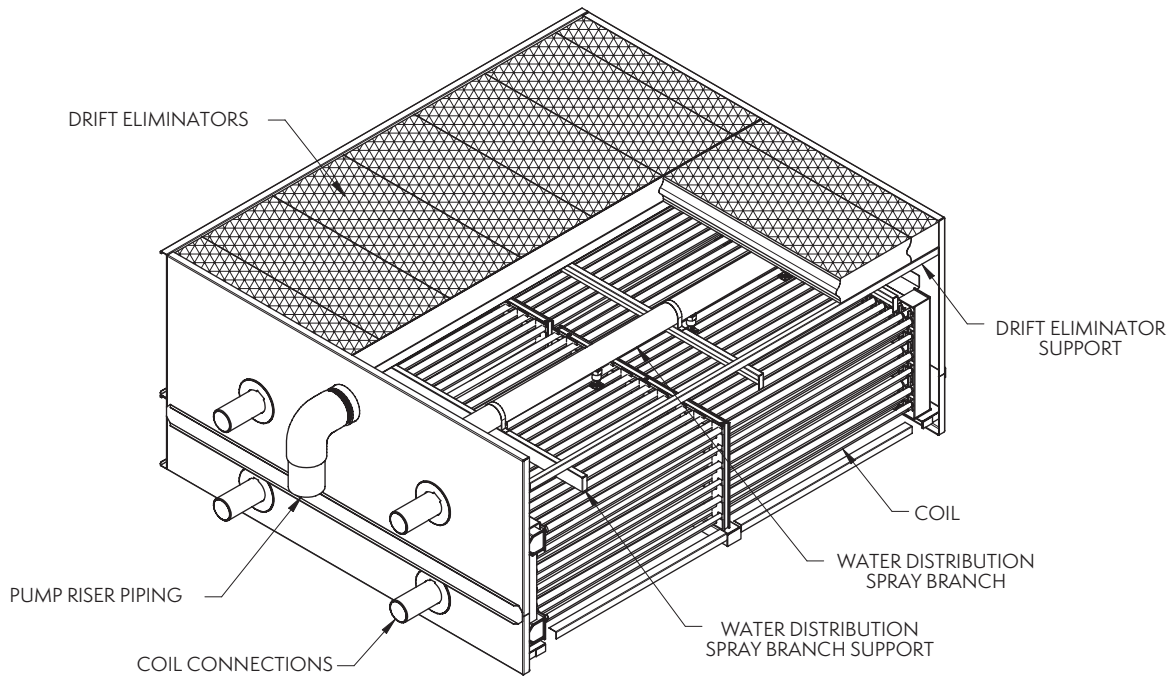

PAN SECTION

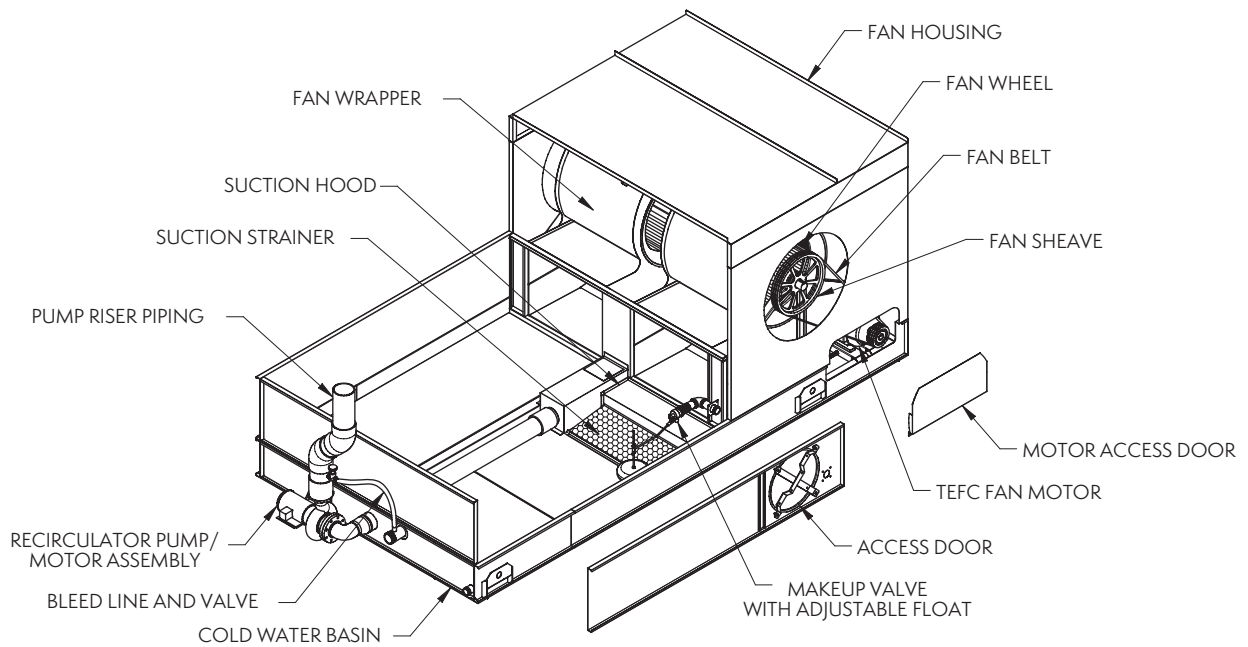

COIL CASING SECTION

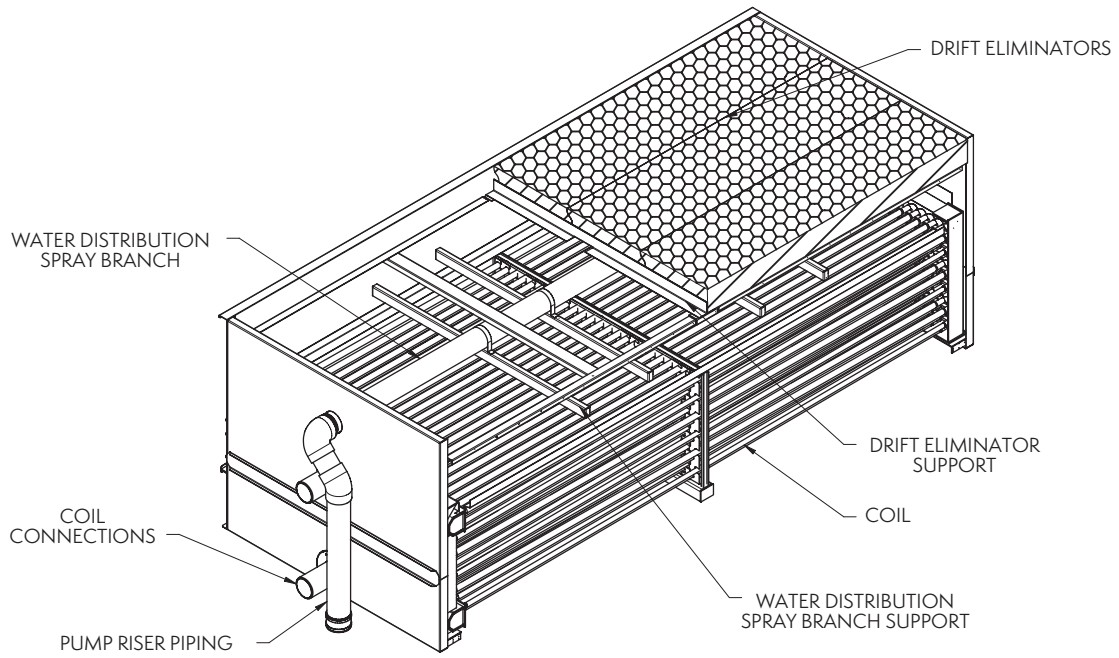

PAN SECTION

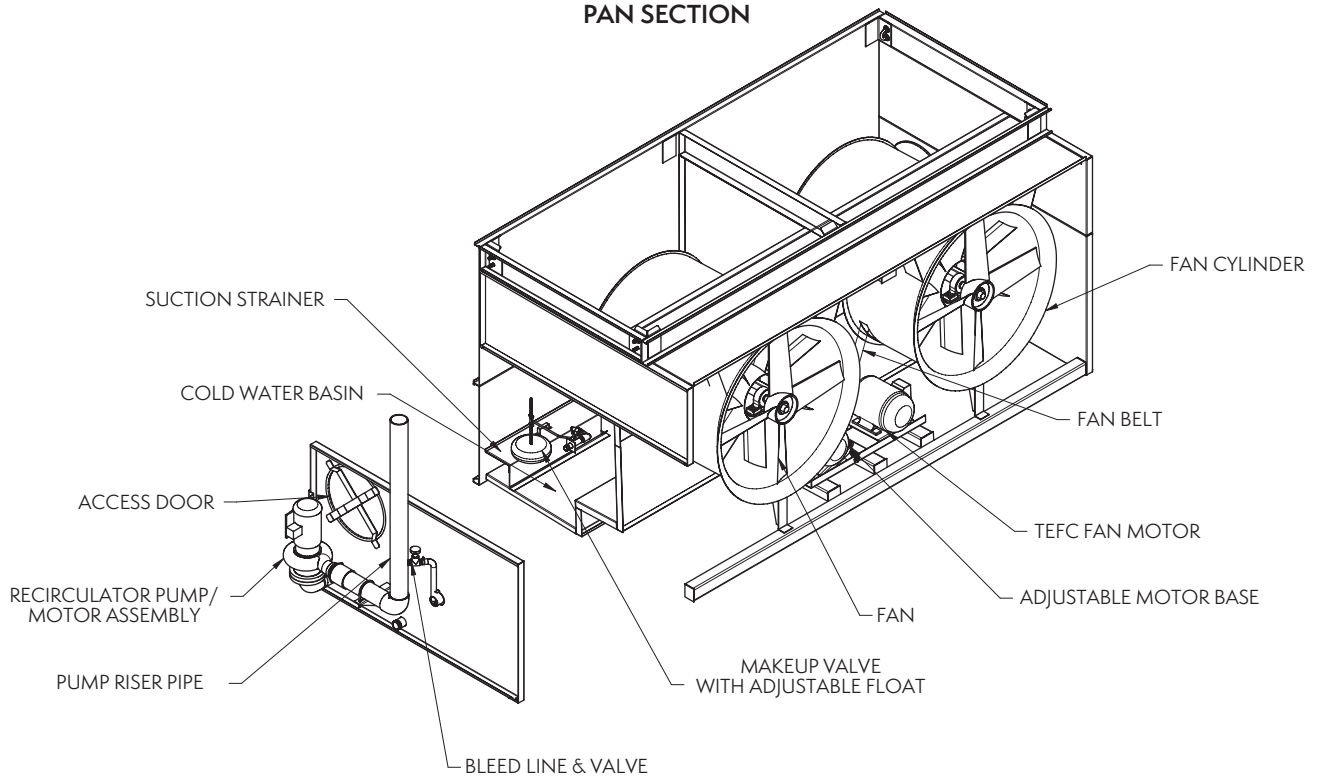

PMRC and eco-PMRC 10' and 12' Units

COIL CASING SECTION

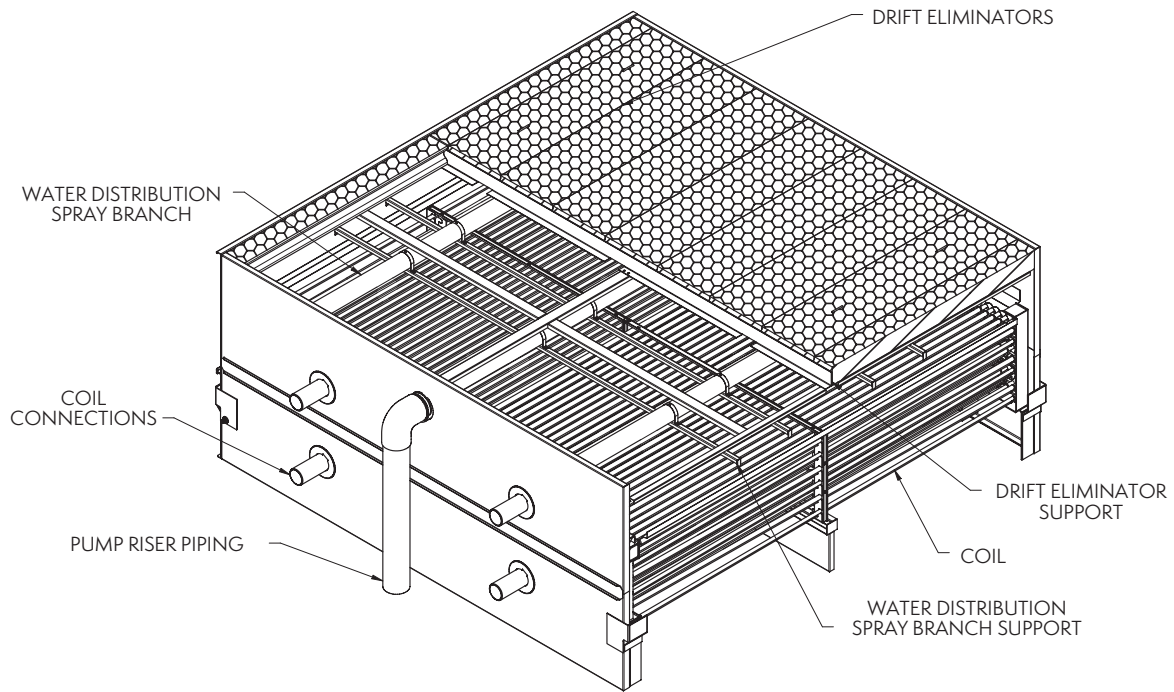

PAN SECTION

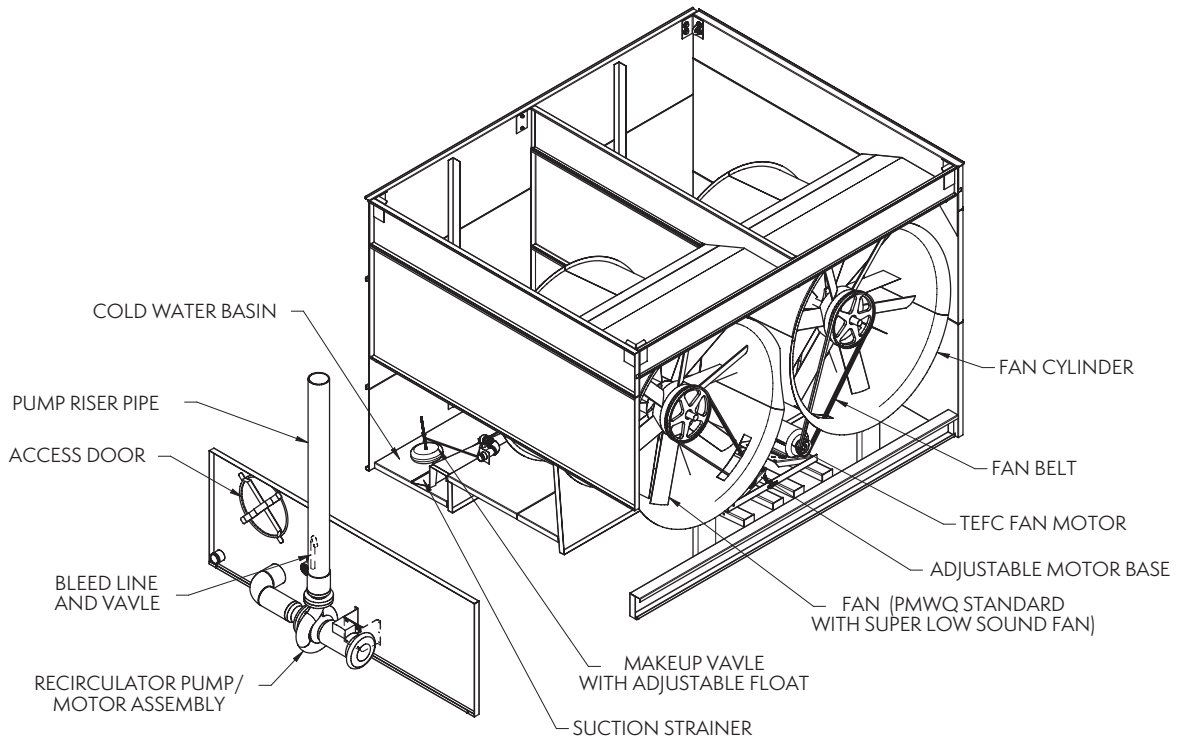

PHC-S 2.24m Wide-Single Side Air Inlet Units

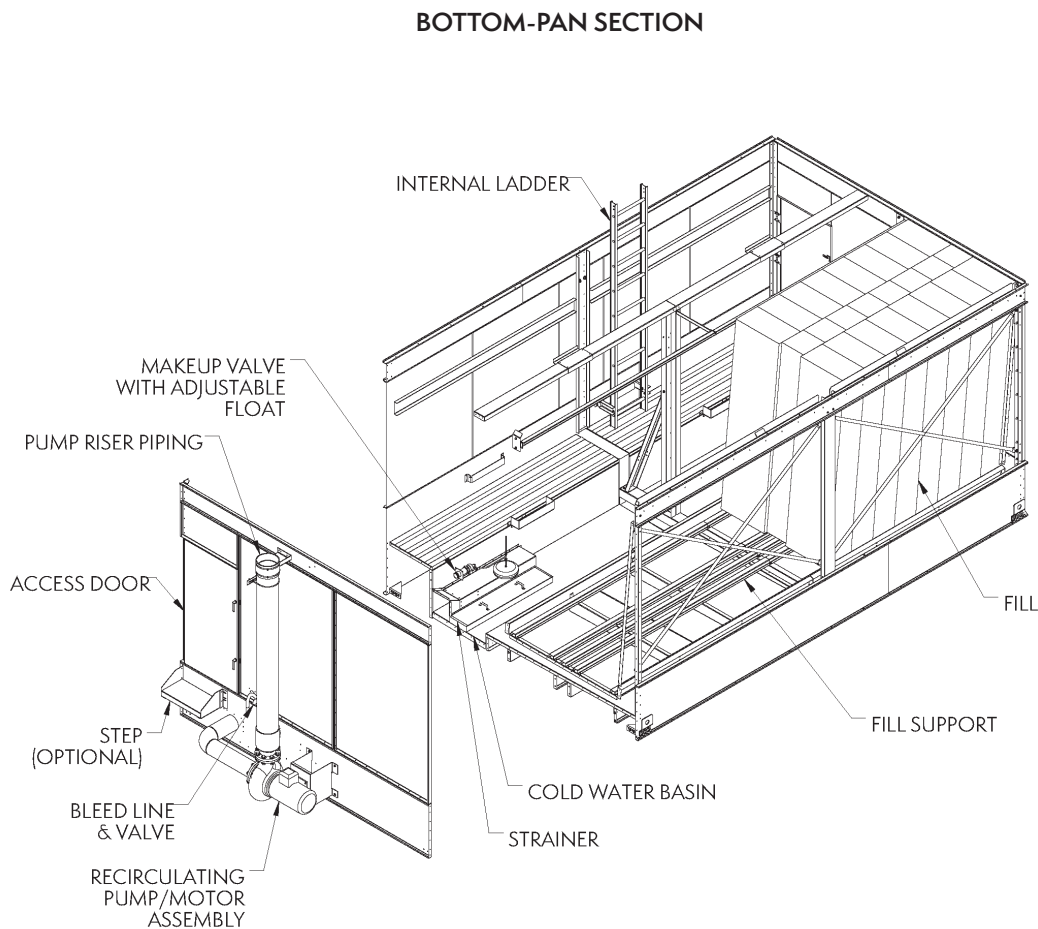
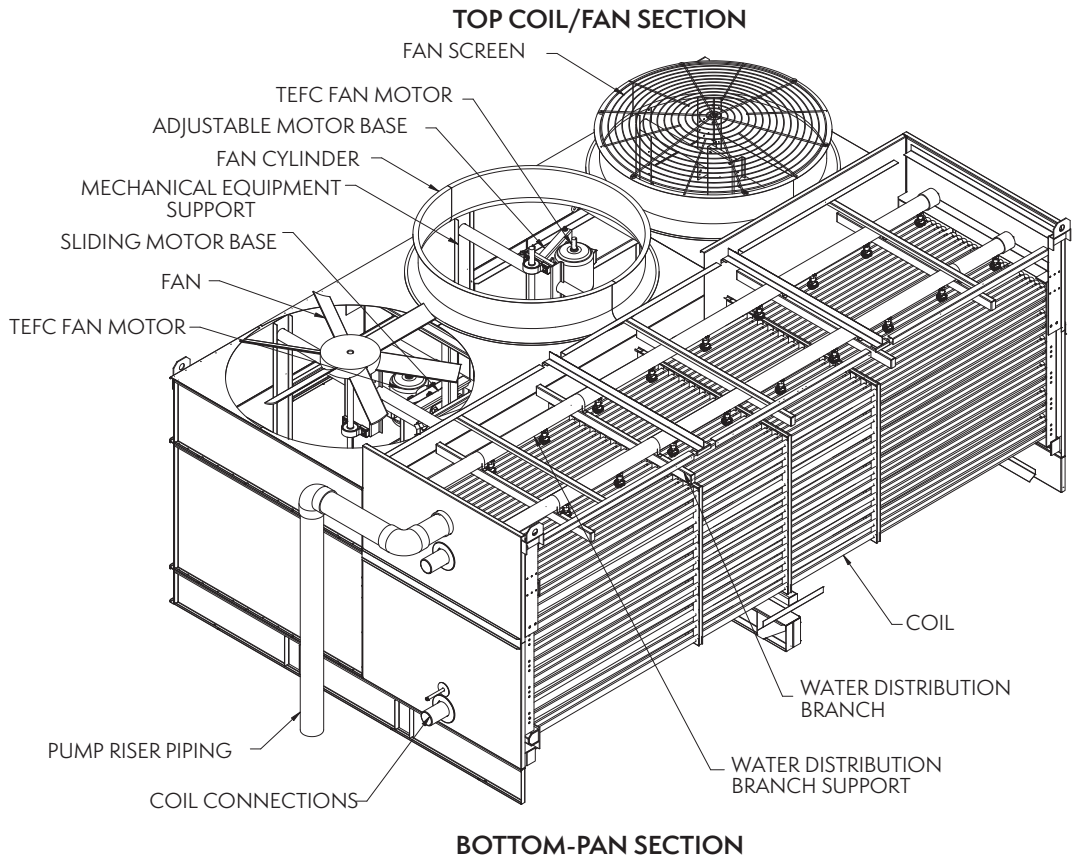

PHC-S 8.5' Wide-Single Side Air Inlet Units

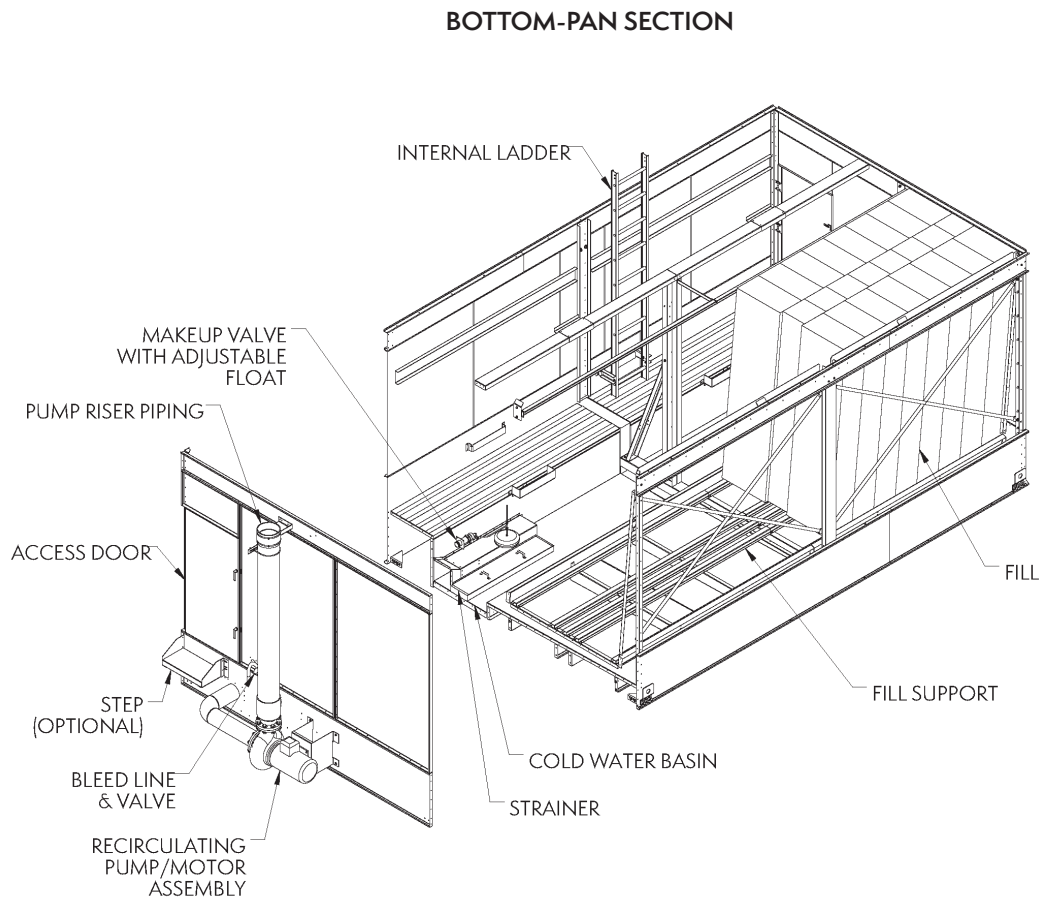
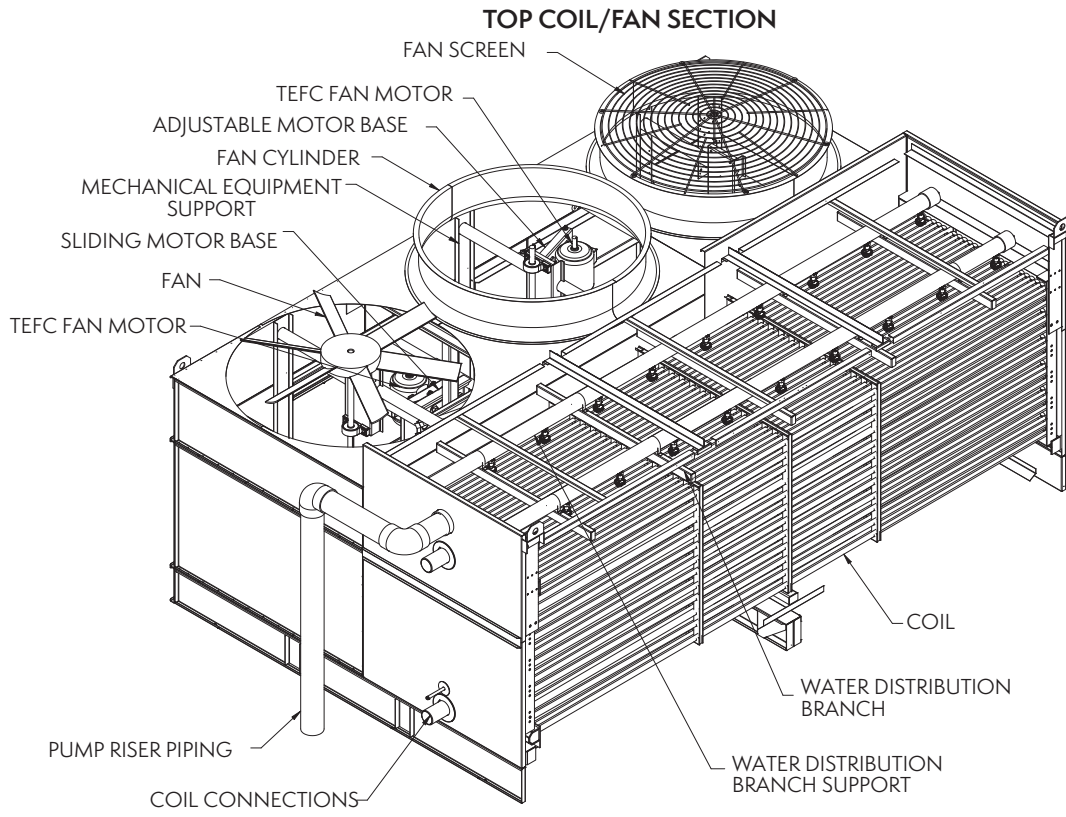

PHC-S 10' and 12' Wide-Single Side Air Inlet Units

TOP COIL/FAN SECTION

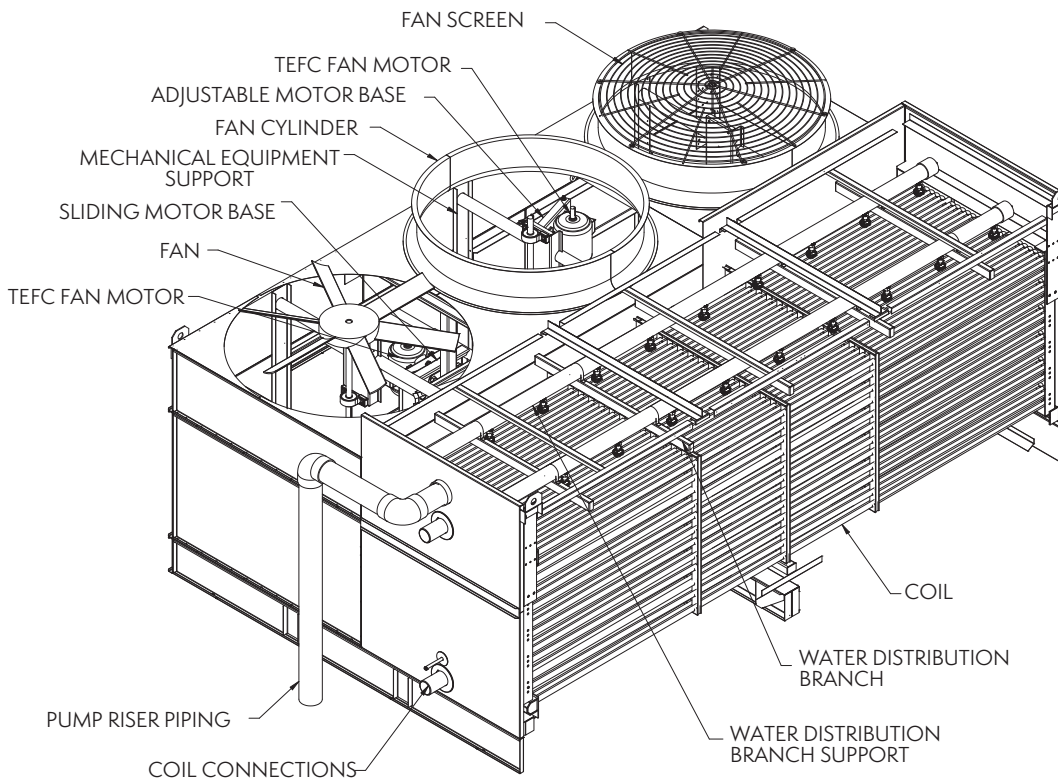

BOTTOM-PAN SECTION

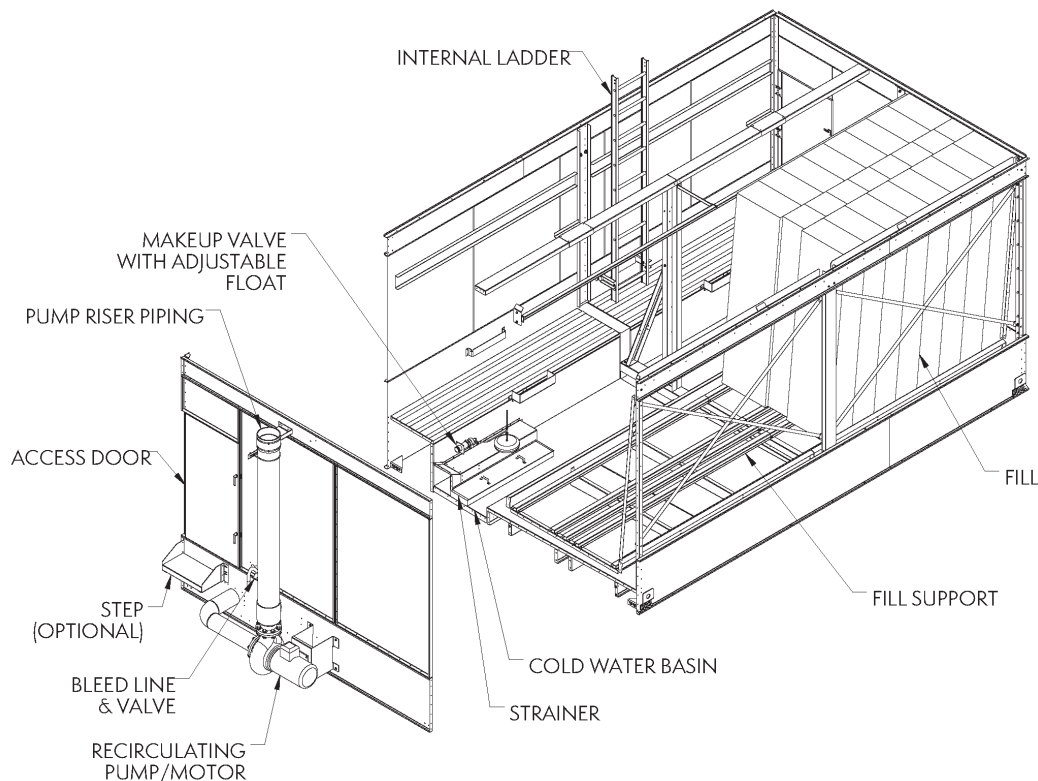

PHC-D 12' and 14' Wide-Two Sided Air Inlet Units

TOP COIL/FAN SECTION

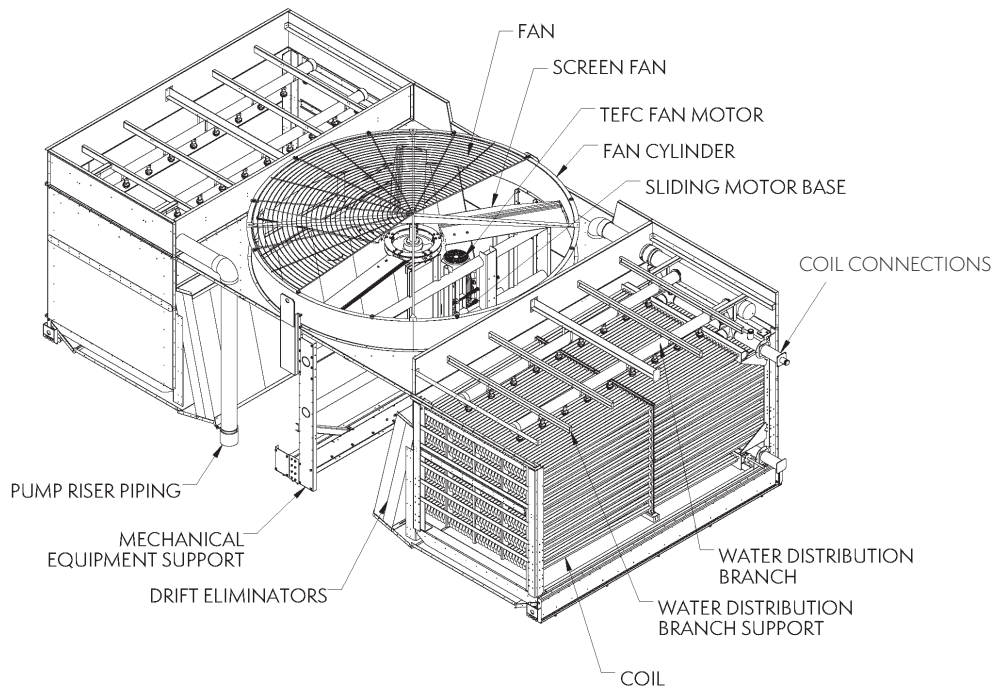

BOTTOM-PAN SECTION

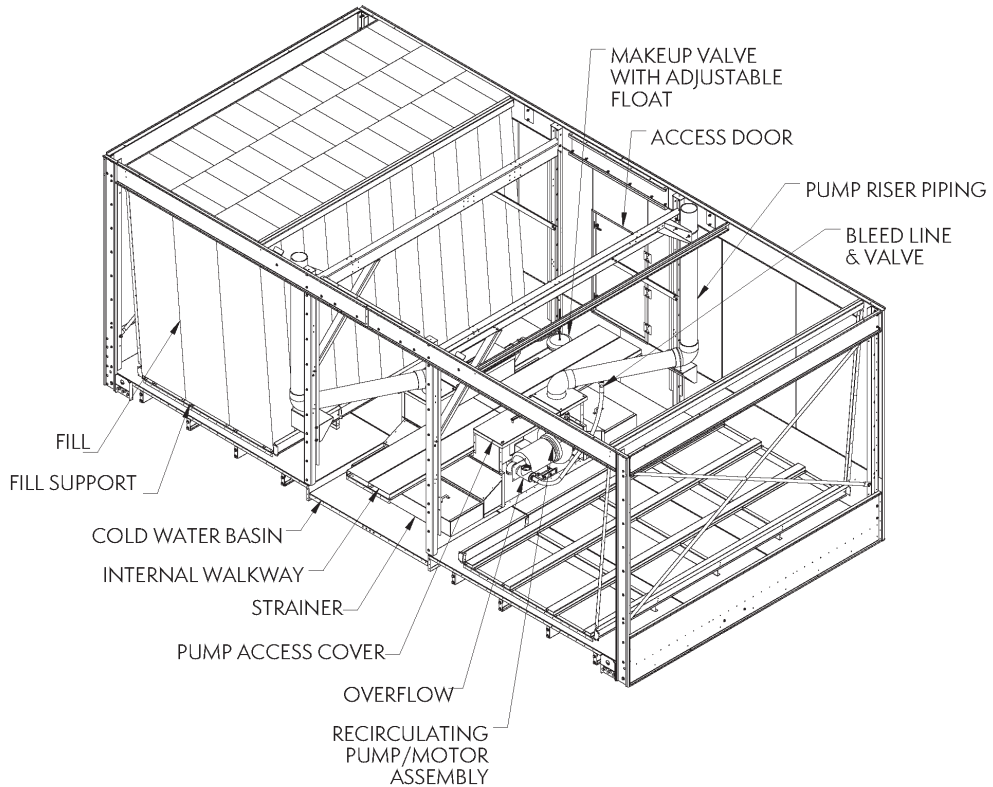

PHW 12' and 14' Wide-Two Sided Air Inlet Units

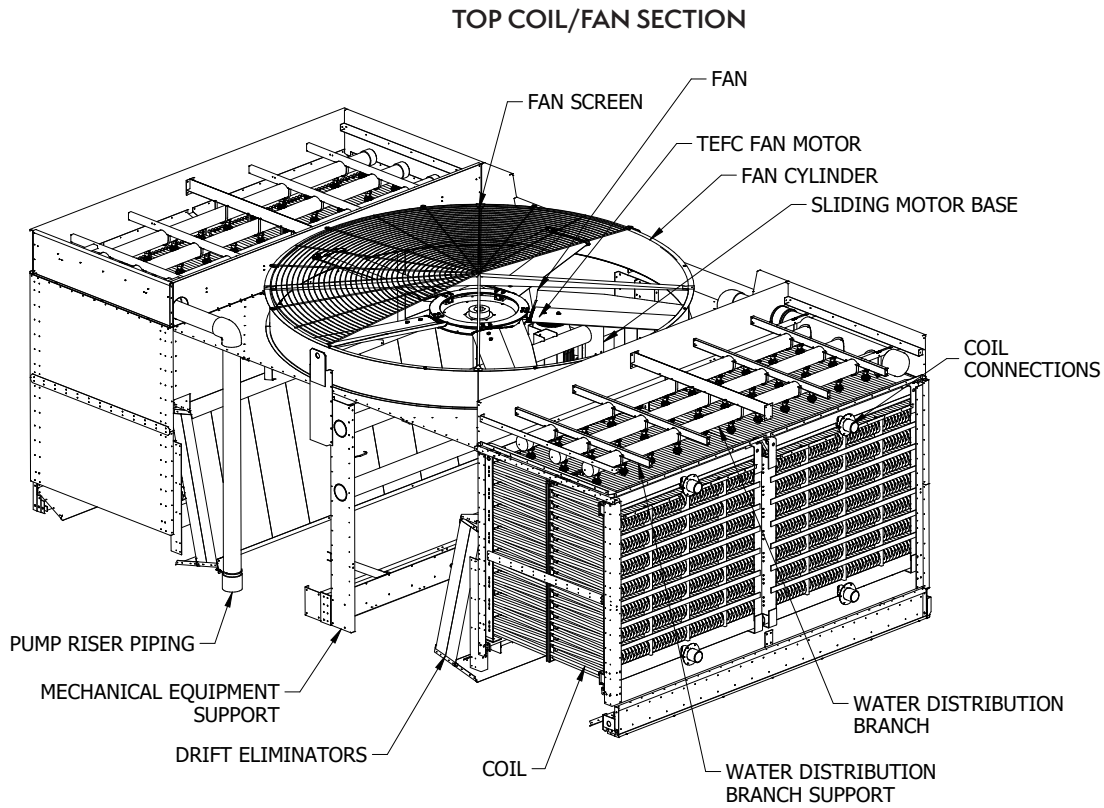

BOTTOM-PAN SECTION

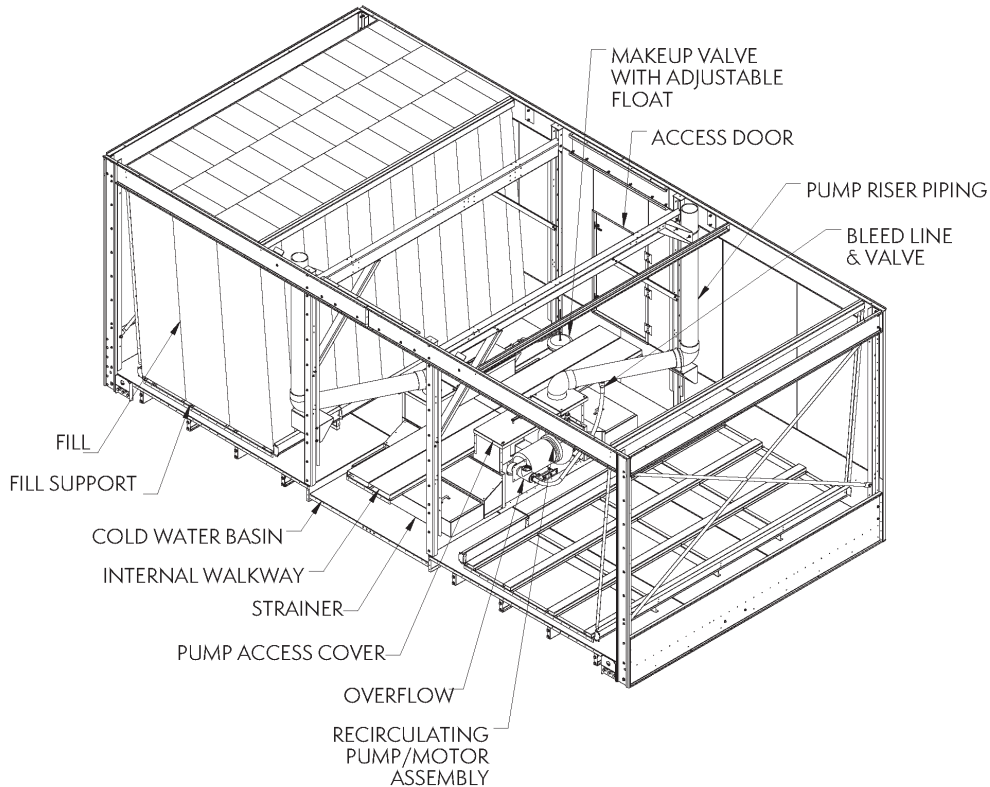

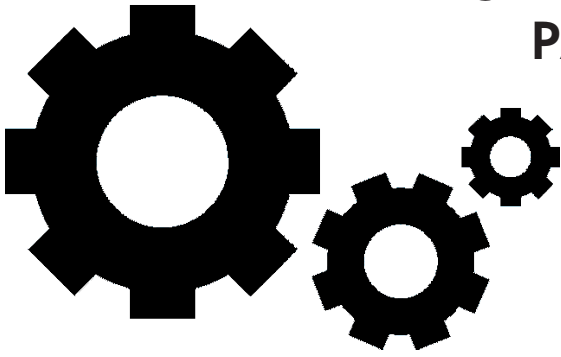

FOR EVAPCO AUTHORIZED PARTS AND SERVICE, CONTACT YOUR LOCAL EVAPCO REPRESENTATIVE OR THE LOCAL SERVICE CENTER



Mr. GoodTower®



EVAPCO, Inc. — World Headquarters & Research / Development Center

P.O. Box 1300 • Westminster, MD 21158 USA
410.756.2600 • marketing@evapco.com • evapco.com

North America

EVAPCO, Inc.
World Headquarters
Westminster, MD USA
410.756.2600
marketing@evapco.com

EVAPCO East
Taneytown, MD USA

EVAPCO East
Key Building
Taneytown, MD USA

EVAPCO Midwest
Greenup, IL USA
217.923.3431
evapcomw@evapcomw.com

Evapcold Manufacturing
Greenup, IL USA

EVAPCO Newton
Newton, IL USA
618.783.3433
evapcomw@evapcomw.com

EVAPCO West
Madera, CA USA
559.673.2207
contact@evapcowest.com

EVAPCO Alcoil, Inc.
York, PA USA
717.347.7500
info@evapco-alcoil.com

EVAPCO Iowa
Lake View, IA USA

EVAPCO Iowa
Sales & Engineering
Medford, MN USA
507.446.8005
evapcomn@evapcomn.com

EVAPCO LMP ULC
Laval, Quebec, Canada
450.629.9864
info@evapcolmp.ca

EVAPCO Select Technologies, Inc.
Belmont, MI USA
844.785.9506
emarketing@evapcoselect.com

Refrigeration Vessels & Systems Corporation
Bryan, TX USA
979.778.0095
rvs@rvscorp.com

Tower Components, Inc.
Ramseur, NC USA
336.824.2102
mail@towercomponentsinc.com

EvapTech, Inc.
Edwardsville, KS USA
913.322.5165
marketing@evaptech.com

EVAPCO Dry Cooling, Inc.
Bridgewater, NJ USA
908.379.2665
info@evapcodc.com

EVAPCO Dry Cooling, Inc.
Littleton, CO USA
908.895.3236
info@evapcodc.com

Asia Pacific

EVAPCO Asia Pacific Headquarters
Baoshan Industrial Zone Shanghai, P.R. China
(86) 21.6687.7786
marketing@evapcochina.com

EVAPCO (Shanghai) Refrigeration Equipment Co., Ltd.
Baoshan Industrial Zone, Shanghai, P.R. China

EVAPCO (Beijing) Refrigeration Equipment Co., Ltd.
Huairou District, Beijing, P.R. China
(86) 10.6166.7238
marketing@evapcochina.com

EVAPCO Air Cooling Systems (Jiaxing) Company, Ltd.
Jiaxing, Zhejiang, P.R. China
(86) 573.8311.9379
info@evapcochina.com

EVAPCO Australia (Pty.) Ltd.
Riverstone, NSW, Australia
(61) 02.9627.3322
sales@evapco.com.au

EvapTech (Shanghai) Cooling Tower Co., Ltd
Baoshan District, Shanghai, P.R. China.
Tel: (86) 21.6478.0265

EvapTech Asia Pacific Sdn. Bhd.
Puchong, Selangor, Malaysia
(60) 3.8070.7255
marketing-ap@evaptech.com

Europe | Middle East | Africa

EVAPCO Europe EMENA Headquarters
Tongeren-Borgloon, Belgium
(32) 12.39.50.29
evapco.europe@evapco.be

EVAPCO Europe BV
Tongeren-Borgloon, Belgium

EVAPCO Europe, S.r.l.
Milan, Italy
(39) 02.939.9041
evapcoeuropa@evapco.it

EVAPCO Europe, S.r.l.
Sondrio, Italy

EVAPCO Europe A/S
Aabybro, Denmark
(45) 9824.4999
info@evapco.dk

EVAPCO Europe GmbH
Meerbusch, Germany
(49) 2159.69560
info@evapco.de

EVAPCO Middle East DMCC
Dubai, United Arab Emirates
(971) 56.991.6584
info@evapco.ae

Evap Egypt Engineering Industries Co.
A licensed manufacturer of EVAPCO, Inc.
Nasr City, Cairo, Egypt
(20) 10.054.32198
evapco@riba-group.com

EVAPCO S.A. (Pty.) Ltd.
A licensed manufacturer of EVAPCO, Inc.
Isando, South Africa
(27) 11.392.6630
evapco@evapco.co.za

South America

EVAPCO Brasil
Equipamentos Industriais Ltda.
Sorocaba, São Paulo, Brazil
(55) 11.5681.2000
vendas@evapco.com.br

FanTR Technology Resources
Sorocaba, São Paulo, Brazil
(55) 11.4025.1670
fantr@fantr.com



TECHNOLOGY FOR THE FUTURE, AVAILABLE TODAY
Visit EVAPCO's website: evapco.com

