

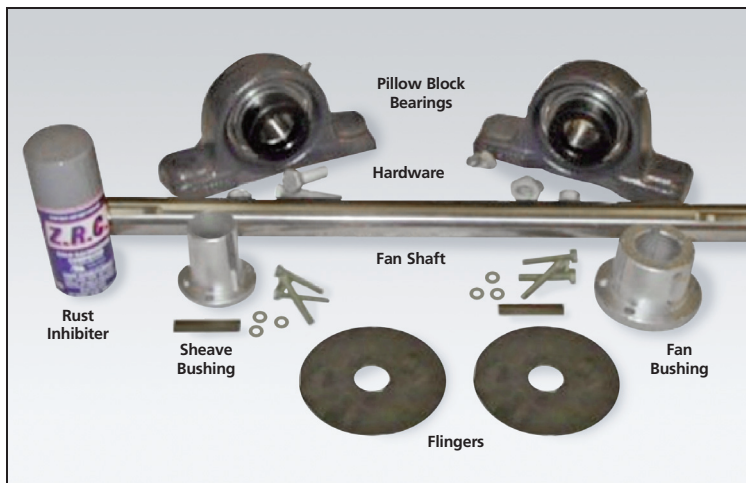

REPLACEMENT SHAFT KITS

For ALL Manufacturers' Evaporative Cooling Equipment
EVAPCO, BAC, MARLEY, IMECO, RECOLD and more...



Solid Shaft Kit

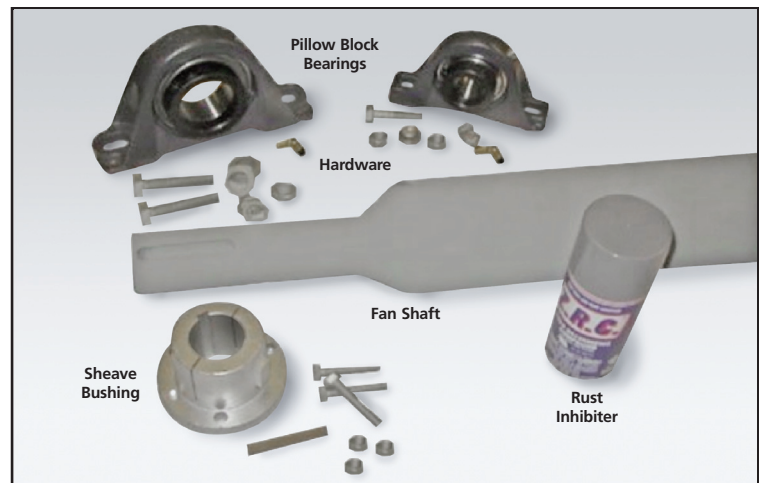

Tubular Shaft Kit

Complete Kit

EVAPCO's shaft replacement kit includes all the necessary components and instructions for repairs in one shipment!

Quick Shipment

Shaft kits are available for immediate shipment, eliminating costly delays!

Quality Custom Design



EVAPCO can supply shaft kits for other manufacturer's equipment. All shaft kits for other manufacturer's equipment come with a 2 year replacement parts warranty! This is double the warranty of most manufacturers!

Quality Components

- All EVAPCO heavy duty, self aligning bearings are "Cooling Tower Rated" to have an L10 life of 75,000 Hours.
- EVAPCO's tubular shafts are constructed with superior forged steel journals with a 0.25" wall thickness compared to the competitor's welded steel tubular shaft.
- EVAPCO's tubular shafts are factory balanced to compensate for static, kinetic, dynamic, and whip unbalances.

**Call your local
Mr. GoodTower® for a Free
Unit Inspection on all Brands
and Models of Evaporative
Cooling Equipment.**

Call **EVAPCO** at **410-756-2600** for the Mr. GoodTower® Service Center near you.

Visit Mr. GoodTower's website at: **MrGoodTower.com**

Reduce Costs!

- Minimize unit downtime by having all necessary parts for the job!
- Prevent multiple shipping charges with a complete kit in a single shipment!
- All parts in the EVAPCO shaft kit on site at once!

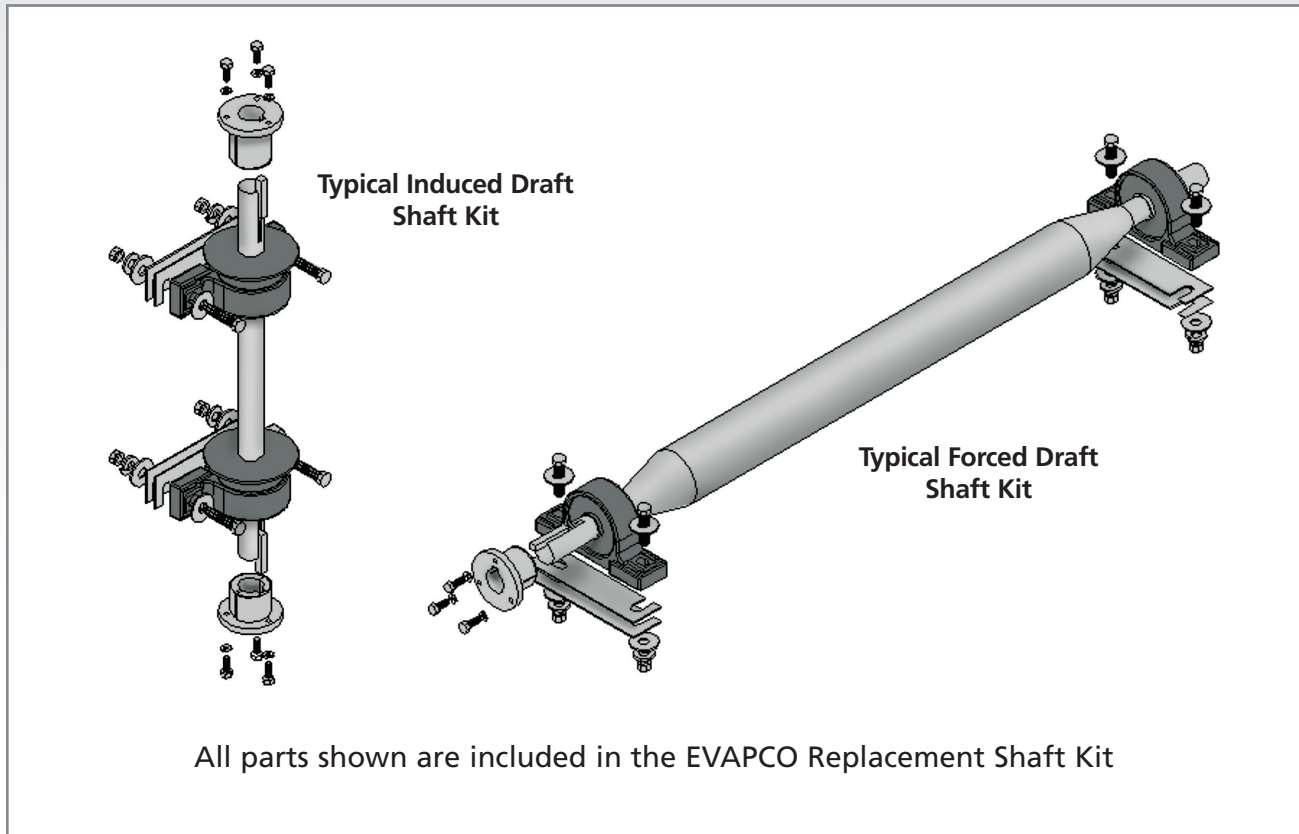

EVAPCO...Specialists in Heat Transfer Products and Services.



Mr. GoodTower®



For A Free Unit Inspection Contact Your Local Mr. GoodTower® Service Center at:

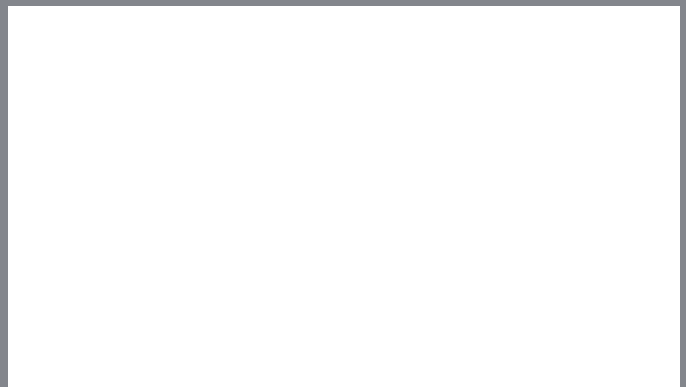

Call EVAPCO at 410-756-2600 for the Mr. GoodTower® Service Center near you.

*Visit Mr. GoodTower's website at: **MrGoodTower.com***